

# M 130

## Dynamic Double-Ribbon Microphone

Order # 730.173



### FEATURES

- Dynamic double-ribbon microphone
- Figure-eight polar pattern
- Excellent suppression of lateral noise
- High impulse fidelity and good transient response
- Handcrafted in Germany

### APPLICATION

The M 130 is ideal for stereo, room and instrument recordings and brings a popular and special ribbon sound that is characterised by warmth and precision. Depending on positioning and spatial situation, the M 130 can be used for studio recordings of drums, electric guitar amps, piano, acoustic guitars, orchestras, choirs or for all kinds of atmospheric recordings.

As a stereo microphone system, two M 130 can be used to create a Blumlein stereo system for an excellent sounding room recording. M/S recordings can be made together with a hypercardioid or supercardioid microphone such as the M 160 dynamic double-ribbon microphone or the MC 950 true condenser microphone.

### TECHNICAL SPECIFICATIONS

|                             |                         |
|-----------------------------|-------------------------|
| Transducer type             | Dynamic                 |
| Operating principle         | Pressure gradient       |
| Frequency response          | 40 - 18,000 Hz          |
| Polar pattern               | Figure-eight            |
| Rear attenuation at 1 kHz   | > 30 dB at 90°          |
| Sensitivity (0 dB = 1 V/Pa) | 1.3 mV/Pa (= -57.5 dBV) |
| Nominal impedance           | 200 Ω                   |
| Load impedance              | ≥ 1000 Ω                |
| Diaphragm                   | Pure aluminium          |
| Case/finish                 | Brass                   |
| Connector                   | XLR, 3-pin, male        |
| Dimensions:                 |                         |
| Length                      | 128 mm                  |
| Shaft diameter              | 23 mm                   |
| Head diameter               | 38.5 mm                 |
| Weight                      | 160 g                   |

### SUPPLIED ACCESSORY

|          |   |                 |
|----------|---|-----------------|
| MA-CL 25 | Microphone clamp with 3/8" internal thread, with internal diameter of 25 mm | Order # 727.954 |
|----------|---|-----------------|

**CREATE THE AMAZING**



# M 130

## Dynamic Double-Ribbon Microphone

Order # 730.173

### FREQUENCY RESPONSE & POLAR PATTERN

This polar pattern and frequency response curve correspond to a typical production sample for this microphone.

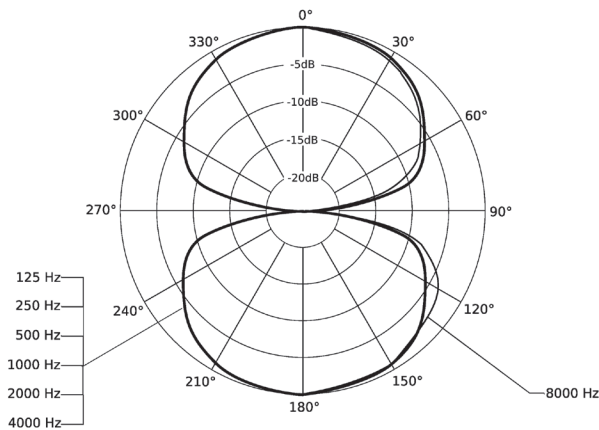
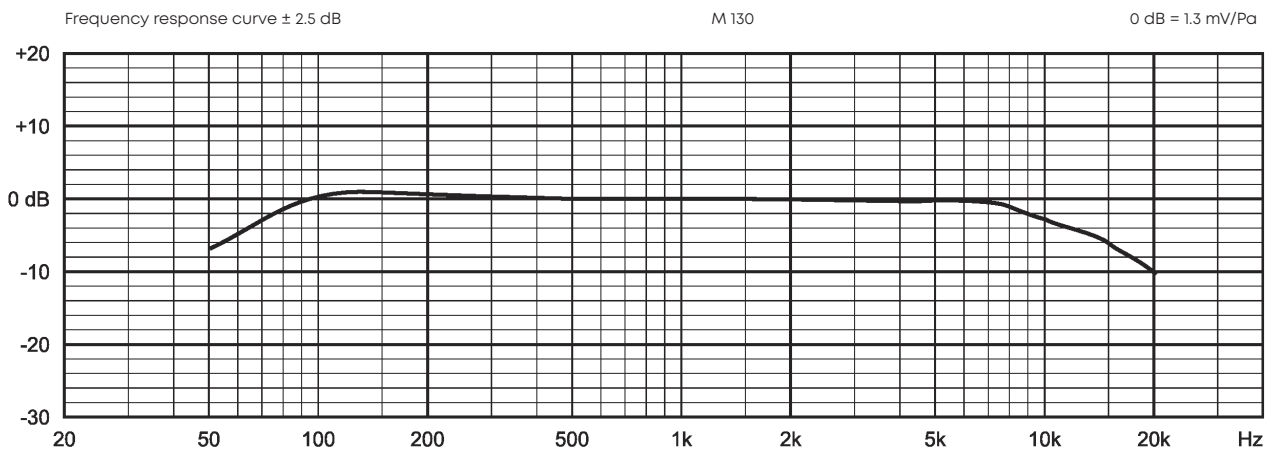

### WIRING DIAGRAM

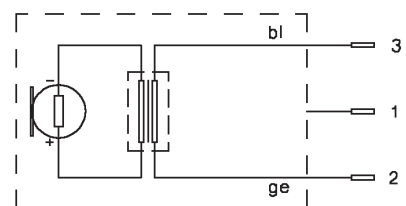

**CREATE THE AMAZING**

