

BOSE[®] SOUNDCOMM[™] B30 headset



Single earcup



Dual earcup

IMPORTANT SAFETY INSTRUCTIONS

Please read and keep all safety and use instructions.

ATTENTION: This is a professional headset. Commercial use is subject to the rules and regulations of the trade association responsible. This system is capable of producing sound pressure exceeding 85 dB(A).

To prevent hearing damage, avoid high volumes and long durations of headset use at higher volumes.

The following may be signs that you have been subjected to excessive noise for too long a time: You can hear ringing or whistling noise in your ears; or you have the impression that you can no longer hear high frequencies.

WARNINGS/CAUTIONS

- **DON'T** use the headset at a high volume for any extended period.
 - To avoid hearing damage, use your headset at a comfortable, moderate volume level.
 - Turn the volume down on your device before placing the headset on your ears, then turn the volume up gradually until you reach a comfortable listening level.
- **DON'T** use the headset if it emits a loud squeal or other loud noise. Contact Bose technical support if the headset emits any loud or unusual noise.
- **DO** focus on your safety and that of others if you use the headset while engaging in any activity requiring your attention. Remove the headset or adjust your volume to ensure you can hear surrounding sounds, including alarms and warning signals.
- **DON'T** use the headset as an aviation communication headset.
- **DO** remove the headset and disconnect immediately if you experience a warming sensation or loss of audio.
- **DO** use only attachments/accessories specified by the manufacturer.
- **DO** use only AA alkaline batteries. Replace the batteries only with AA alkaline batteries. There is a danger of explosion if batteries are incorrectly replaced with any other battery chemistries. Batteries may cause a fire or chemical burn if mishandled. Do not recharge, disassemble, heat, or incinerate batteries. Dispose of used batteries properly, following any local regulations.
- **DON'T** short-circuit the battery. **DON'T** store batteries carelessly in a box or drawer where they may short-circuit each other or be short-circuited by other metal objects. **DO** remove the battery from the equipment when not in use. In the event of a battery leaking, **DON'T** allow the liquid to come in contact with the skin or eyes. If contact has been made, wash the affected area with copious amounts of water and seek medical advice. **DON'T** mix cells of different manufacture, capacity, size or type within a device.
- **DON'T** repair the headset yourself. Do not attempt to remove, replace, or repair the protective inner screen on the inside of the earcup, which is critical to the headset's performance. If screen replacement or other repair seems necessary, contact Bose technical support. See "Contact information" on page 20. If the screen gets wet or any foreign objects become lodged on or adjacent to it, follow the instructions in "Cleaning the headset" on page 15.
- **DON'T** place naked flame sources, such as lighted candles, on or near the product .
- **DON'T** make unauthorized alterations to the product; doing so may compromise safety, regulatory compliance, system performance, and may void the warranty.



Contains small parts which may be a choking hazard. Not suitable for children under age 3.



This product contains magnetic material. Consult your physician on whether this might affect your implantable medical device.

NOTE: This equipment has been tested and found to comply with the limits for a Class B digital device, pursuant to Part 15 of the FCC Rules. These limits are designed to provide reasonable protection against harmful interference in a residential installation. This equipment generates, uses, and can radiate radio frequency energy and, if not installed and used in accordance with the instructions, may cause harmful interference to radio communications. However, there is no guarantee that interference will not occur in a particular installation. If this equipment does cause harmful interference to radio or television reception, which can be determined by turning the equipment off and on, the user is encouraged to try to correct the interference by one or more of the following measures:

- Reorient or relocate the receiving antenna.
- Increase the separation between the equipment and receiver.
- Connect the equipment into an outlet on a circuit different from that to which the receiver is connected.
- Consult the dealer or an experienced radio/TV technician for help.

Changes or modifications not expressly approved by Bose Corporation could void the user's authority to operate this equipment.

This device complies with part 15 of the FCC Rules. Operation is subject to the following two conditions: (1) This device may not cause harmful interference, and (2) this device must accept any interference received, including interference that may cause undesired operation

CAN ICES-3 (B)/NMB-3(B)

©2016 Bose Corporation. No part of this work may be reproduced, modified, distributed or otherwise used without prior written permission.

CONTENTS

Getting Started

Components.....	6
-----------------	---

Preparing the Headset for Use

Installing the batteries	7
Attaching the control module to the radio or intercom belt pack (optional).....	8
Connecting the control module to the belt pack.....	10
Detaching the control module from the belt pack	11

Using the Headset

Acoustic Noise Cancelling™ noise reduction.....	12
Power indicator.....	12
Wearing the headset	13
Left and right earcup markings.....	13
Adjusting the headset fit	13
Microphone rotation	13
Microphone placement	14
Storing the headset.....	14

Care and Maintenance

Cleaning the headset 15

Headband cushion..... 15

Earcup inner screen (scrim)..... 15

Microphone windscreen 15

Replacing parts..... 16

Side pad replacement (single earcup)..... 16

Microphone windscreen replacement..... 16

Battery replacement..... 16

Ear cushion replacement 17

Locating the headset serial number..... 18

Technical information 19

Warranty 20

Contact information..... 20

Ordering parts and accessories..... 20

Troubleshooting

Common solutions..... 21

Components

SoundComm™ B30 Headset
(single earcup or dual earcup)

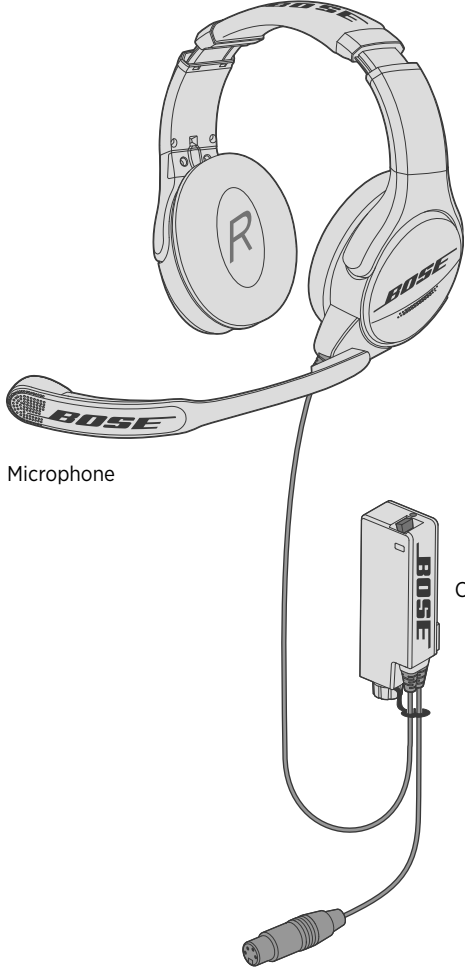

Microphone

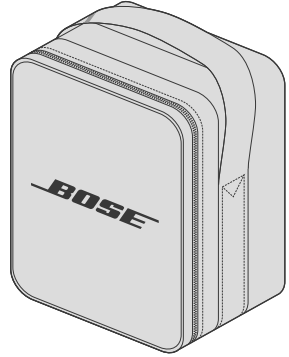

Carry case

Control module

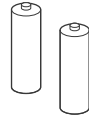

2 AA alkaline batteries

4-pin or 5-pin XLR connector

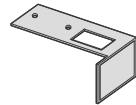

Belt pack bracket (2)
(optional)

Installing the batteries

1. Insert two AA alkaline batteries into the compartment as shown.
2. Tighten the battery cap until snug.

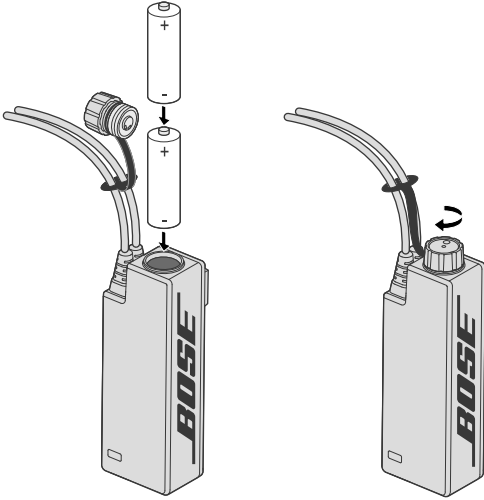

Note: Replace batteries with AA alkaline batteries only.

Attaching the control module to the radio or intercom belt pack (optional)

1. On the back of the radio or intercom belt pack, loosen the two screws and remove the wire belt clip.

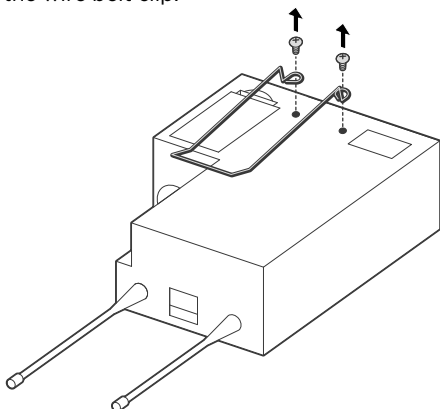

2. Place the belt pack bracket on top of the belt pack, lining up the screw holes.

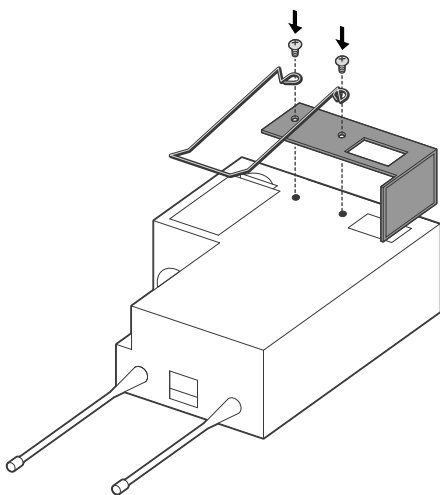

3. Place the wire belt clip on top of the bracket, lining up the screw holes.

PREPARING THE HEADSET FOR USE

4. Re-install the two screws, and tighten until snug.

Note: If the connection does not feel secure, the screws may be too short. Use the screws provided with the belt pack bracket (available separately).

5. Line up the dual lock tab on the control module with the dual lock tab on the belt pack bracket. Press firmly to attach.

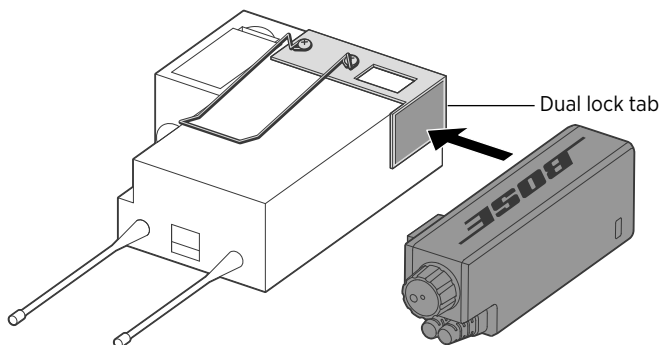

Connecting the control module to the belt pack

1. Line up the pins on the belt pack connector with the holes in the XLR connector.
2. Press firmly until you hear a click.

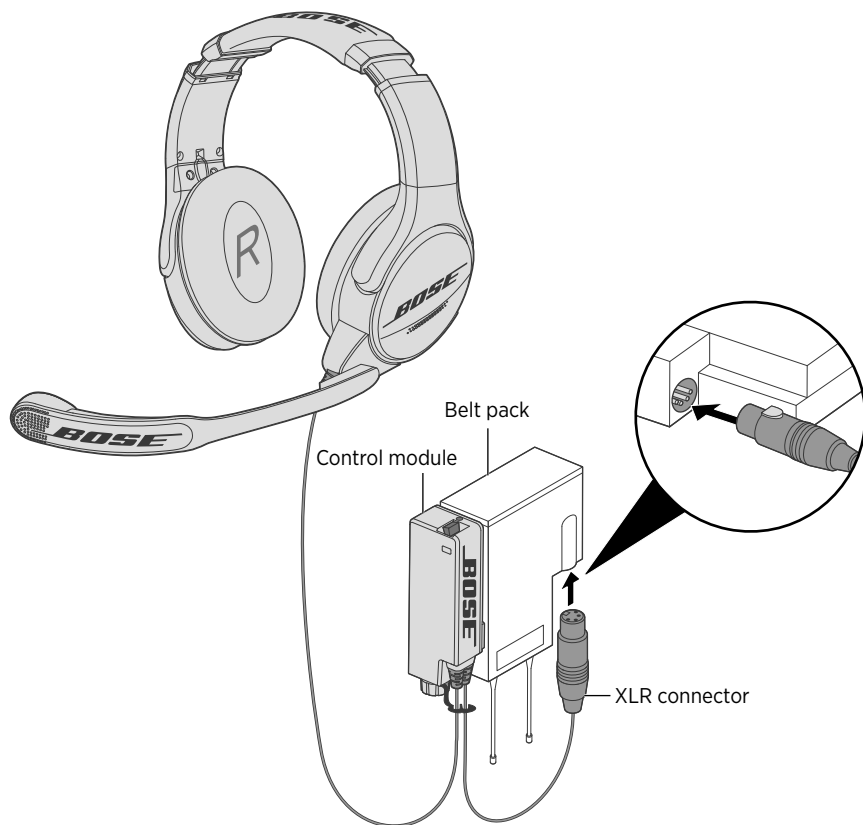

Detaching the control module from the belt pack

1. On the XLR connector, press down on the metal tab and gently pull the cable away from the belt pack.

Note: Most belt packs have a locking mechanism.

2. Starting at the bottom, pry the control module away from the dual lock tab on the belt pack.

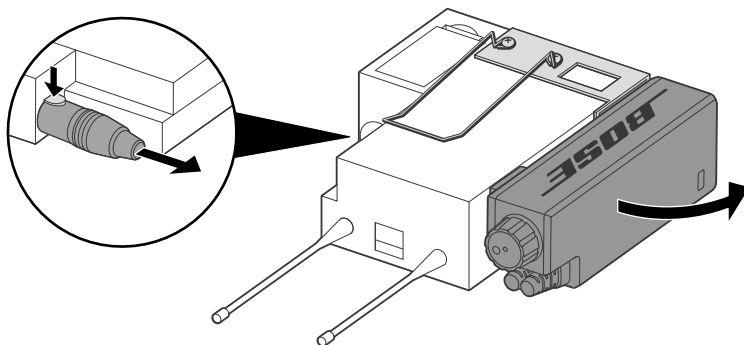

Acoustic Noise Cancelling™ noise reduction

Use the power switch on the control module to turn noise reduction on and off.

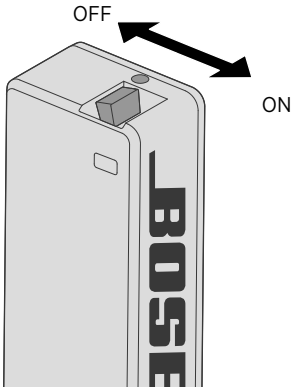

Note: When the power is off, the headset still provides audio and communications. To conserve battery life, turn the switch off when the headset is not in use.

Power indicator

The power indicator is located next to the power switch.

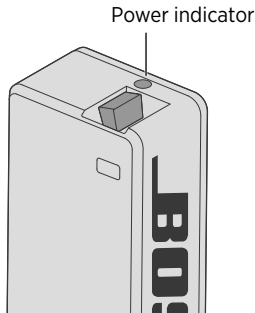

Color	Indicates
Green flashing	Sufficient battery life
Slow red flashing	10 hours or less remaining
Fast red flashing	2.5 hours or less remaining

Note: When the headset is powered on, the power indicator glows red for three seconds while the system checks battery status. After three seconds, the indicator shows the actual battery status.

Wearing the headset

Left and right earcup markings

The inside of each earcup (scrim) is clearly marked with an L (left) or an R (right). Be sure to wear the headset in the correct orientation.

Right earcup marking (scrim)



Adjusting the headset fit

- As you put the headset on, lightly grasp each earcup and adjust it so its cushion is completely over your ear. You should feel an even, gentle pressure all around each ear.
- Make sure to adjust the headband evenly, so the headband is centered on top of your head. The headband should rest gently on your head.
- Make your final adjustments with the headset powered on in a noisy environment.

Microphone rotation

The microphone is intended to rotate no more than 160° as shown.

Do not force the microphone beyond the intended rotation. Only use the microphone on the earcup (left or right) it was designed for.

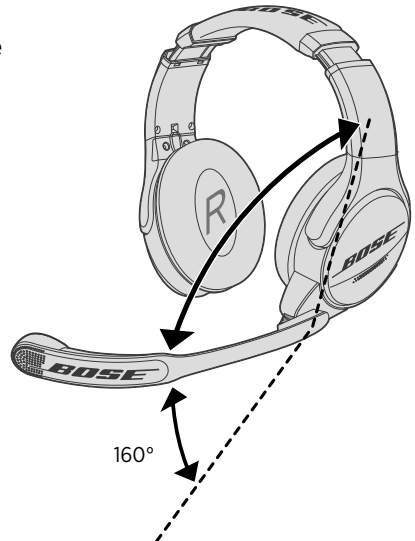

Microphone placement

Microphone placement is important for clear communications. With the headset on your head, make these adjustments:

1. Grasp the boom with your fingers and move the microphone up or down so it is level with your mouth.
2. Pull the microphone in toward your lips. Position the microphone with its talk side facing in. The microphone should be 1/2 inch from your lips.

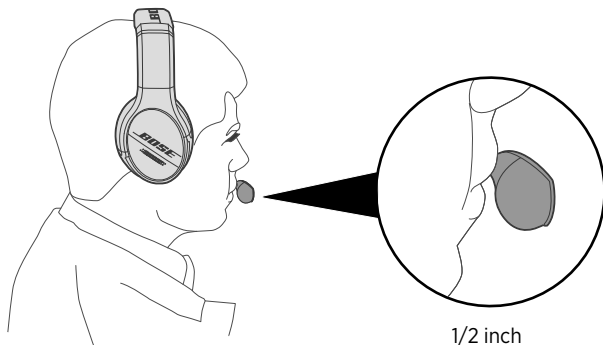

3. Make sure the microphone windscreen is facing your lips and the Bose® logo is facing out. Do not purse your lips.

Storing the headset

The headset should be stored in the supplied carry case as shown. Be sure to place the headset with the microphone face up, and the cable carefully laid across the center hinge of the case.

Note: When storing the headset for an extended period, remove the batteries to avoid battery leakage.

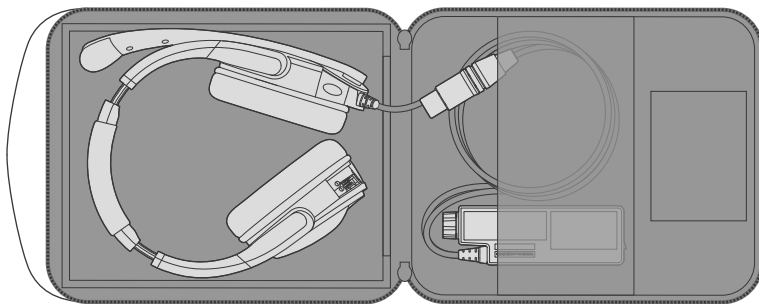

Cleaning the headset

Gently wipe the outside surfaces of the headset, using a soft cloth moistened with water and mild soap. Take special care when cleaning the ear cushions and the outside surfaces of the earcups. Do not immerse the ear cushions in water or any other liquid.

When wiping down the headset earcups, be sure not to force any dirt or debris into the openings. Carefully use tweezers, if necessary, to remove foreign matter that may be lodged in the openings. Do not blow air into or vacuum the openings as this may damage the headset.

WARNING: If the inner screens inside the earcups (scrims) become damp from environmental moisture such as light rain, dew, perspiration, or condensation, allow it to air dry only. Do not use electric heaters or blowers to dry the inner screen.

Headband cushion

Wipe with damp cloth and mild soap.

Earcup inner screen (scrim)

WARNING: Do not attempt to remove, replace, repair, or clean this component. Located inside the earcup, the inner screen is critical to proper headset operation. If the screen appears damaged or worn out, Contact Bose technical support for a replacement using the contact information on page 20.

Microphone windscreen

Wipe with damp cloth and mild soap. Contact Bose technical support for a replacement windscreen using the contact information on page 20.

WARNING: Do not attempt to disassemble or service the inside of the earcups or other parts of the headset. Only the microphone windscreen, side pad (single earcup), batteries, and ear cushions are replaceable by the user.

Replacing parts

Through normal use, some parts may require periodic replacement. Replacement parts can be ordered directly from Bose® technical support. See “Contact information” on page 20.

WARNING: Do not attempt to disassemble or service the inside of the earcups or other parts of the headset. Only the side pad (single earcup), microphone windscreen, batteries, and ear cushions are replaceable by the user.

Side pad replacement (single earcup)

The side pad is attached to the headband with a dual lock tab.

1. Gently pull the old side pad away from the headband.
2. Line up the new side pad and firmly press until attached.

Microphone windscreen replacement

The microphone windscreen can be removed and replaced.

1. Carefully slide the microphone windscreen off of the microphone.
2. Slide the replacement windscreen on and make sure it fits completely over the microphone.

Battery replacement

Replace the batteries before every game.

Battery life: Single earcup - 56 hours; Dual earcup - 48 hours

Ear cushion replacement

As a general rule, ear cushions should be replaced every 3 – 6 months. You may have to replace them more often if you:

- Have a full beard or heavy whiskers.
- Subject the headsets to severe temperature extremes.
- Put excess strain on the cushions because of improper storage.

Indications that the ear cushions need replacing include:

- Flaking of the outer covering.
- Cuts or tears.
- Flattening of the cushion, reducing the effectiveness of the seal.

To extend the life of the ear cushions, perform regular cleaning as described in “Cleaning the headset” on page 15.

To replace the ear cushions:

1. Grasp the ear cushion skirt where it folds into the slot on the earcup.
2. Gently pull the ear cushion skirt up and away from the earcup.

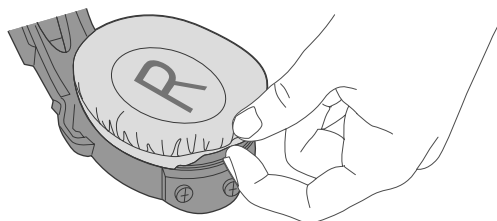

3. Properly align the replacement ear cushion with the earcup.
4. Tuck an edge of the ear cushion skirt into the slot behind the ear cushion flange. Be careful not to fold the skirt over.
5. Gently stretch the cushion around the earcup, working the skirt into the slot as you go.
6. Grasp the ear cushion and adjust its position to remove any folds in the skirt and wrinkles in the cushion.

Locating the headset serial number

Your Bose® SoundComm™ B30 headset is identified by a unique headset serial number located on the left underside of the headband. Reference this serial number when you register your product or contact Bose for technical support.

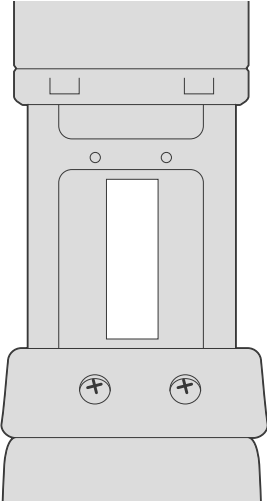

Technical information

Headset impedance

Single earcup: 164 ohm

Dual earcup: 82 ohm

Headset sensitivity @ 1mW @1kHz

Single earcup: 108 dB SPL

Dual earcup (per ear-cup): 105 dB SPL

Microphone type: 150 ohm Dynamic Noise-Cancelling

Weight (not including cable)

Dual earcup: 12.7 oz.

Single earcup: 10 oz.

Cable length: 4 feet 10 inches to control module;
10 inches from control module to connector

4 pin female XLR connector:

Pin 1	Microphone Low
Pin 2	Microphone High
Pin 3	Headphone High
Pin 4	Headphone Low

5 pin male XLR connector:

Pin 1	Microphone Low
Pin 2	Microphone High
Pin 3	Audio_GND
Pin 4	Audio_L
Pin 5	Audio_R

Microphone shield is attached to connector clip.

Warranty

Details of the limited warranty are provided on the warranty/product registration card included in the product carton.

Contact information

Bose technical support

Phone: 800-390-2073

Email: SoundComm_Support@Bose.com

Support hours: Monday – Friday 9:00 AM to 9:00 PM

Ordering parts and accessories

The following accessories and customer-replaceable parts can be purchased directly from Bose®:

- Ear cushion kit (single or dual earcup)
- Microphone windscreen
- Side pad cushion (single earcup)
- Belt pack bracket(s) (optional)
- Battery cap
- Carry case

To order, use the contact information above.

Common solutions

The following table lists symptoms and possible resolutions to common problems.

Problem	What to do
No noise reduction	<ul style="list-style-type: none"> • Make sure the headset is turned on. (Check the power indicator.) • Replace the AA alkaline batteries in the control module. See “Installing the batteries” on page 7. • Check the orientation of the batteries (+ and -). • Make sure the battery terminals are clean. • Make sure the battery cap is tightened. • Check the batteries in the belt pack. <p>DON'T use the headset if it emits a loud squeal or other loud noise. Contact Bose® technical support if the headset emits any loud or unusual noise.</p>
No audio/communications	<ul style="list-style-type: none"> • Check the volume setting on the belt pack. • Make sure the headset cable is securely connected to the belt pack. • Check the internal settings in the belt pack. • Try a different belt pack. • Unplug all non-Bose headsets from the communications system to determine if there is an uneven load. (Wired intercom system only.)
Low volume of incoming communications	<ul style="list-style-type: none"> • Check the volume setting on the belt pack. • Unplug all other headsets and see if the volume level improves. (Wired intercom system only.) • Try another belt pack. • Move closer to the radio base station. A typical wireless belt pack range is 30-50 yards.
Reduced noise reduction, or unusual sounds	<ul style="list-style-type: none"> • Make sure there are no air gaps around the ear cushion seals. If ear cushions appear worn, they should be replaced (see page 17). <p>DON'T use the headset if it emits a loud squeal or other loud noise. Contact Bose technical support if the headset emits any loud or unusual noise.</p>

TROUBLESHOOTING

Problem	What to do
Squealing or whistling sound when the headset is turned on	<ul style="list-style-type: none"> • Make sure the headset orientation is correct. Use the L (left) and R (right) markings inside the earcups to correctly orient the headset. • Inspect the seal between the ear cushion skirt and the earcup. The skirt should fit into the slot on the earcup with no gaps. Replace any cushions that appear to be worn out. • Adjust the earcup fit to create a better seal on your head. The headset's low-force design makes it sensitive to items that interfere with the seal around your ear. Make sure your ears are completely inside the ear cushions, and that a hat or eyeglasses with thick temples do not interfere with the seal. • Make sure the headset ear cushions, internal ear cup foams, and scrims are dry. If not, air dry and retry the headset. If problem persists, contact Bose technical support. <p>DON'T use the headset if it emits a loud squeal or other loud noise. Contact Bose technical support if the headset emits any loud or unusual noise.</p>
Low rumbling sound with the headset turned on in a quiet environment	<ul style="list-style-type: none"> • Adjust the earcup fit to create a better seal on your head. The low-force design of the headset makes it sensitive to items that interfere with the seal around your ear. Make sure your ears are completely inside the ear cushions, and that a hat or eyeglasses with thick temples do not interfere with the seal. • Inspect the seal between the ear cushion skirt and the earcup. The skirt should fit into the slot on the earcup with no gaps. Replace any cushions that appear to be worn out.
Crackling sound audible with headset turned on in a loud environment, or noise reduction is intermittent	<ul style="list-style-type: none"> • Make sure the headset orientation is correct. Use the L (left) and R (right) markings inside the earcups to correctly orient the headset. • Adjust the headset fit. See "Adjusting the headset fit" on page 13. • Replace the AA alkaline batteries in the control module (see page 7). • Inspect the seal between the ear cushion skirt and the earcup. The skirt should fit into the slot on the earcup with no gaps. Replace any cushions that have surface tears, torn stitching joints, large wrinkles, or have become dried and stiff. • Try another belt pack. • Move closer to the radio base station. A typical wireless belt pack range is 30-50 yards.



773320-0010

BOSE[®]
Better sound through research[®]

©2016 Bose Corporation, The Mountain,
Framingham, MA 01701-9168 USA
AM773320 Rev. 00