

BNC RIGHT ANGLED CRIMP/CRIMP PLUG

10-104-W66-FA

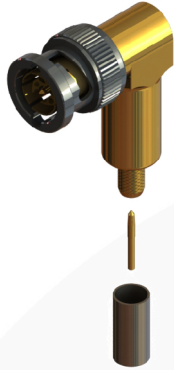

images for illustration purposes only

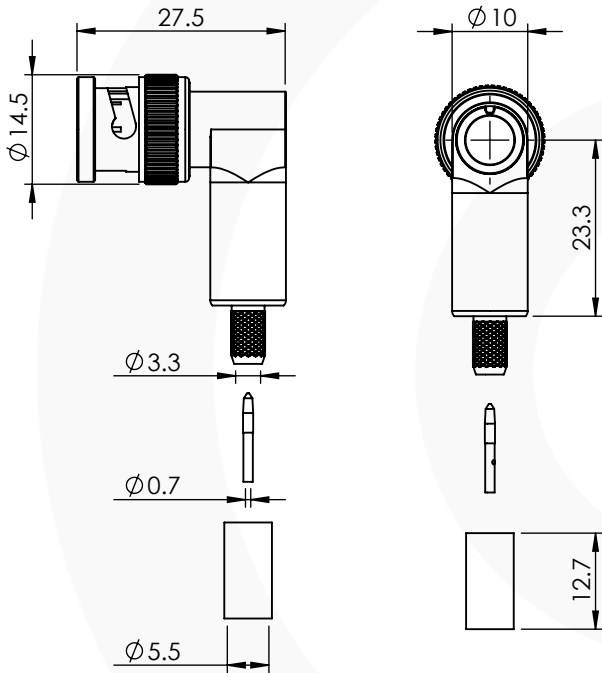

Suitable for Cables:

(FA) Belden 1855ENH, Draka 0.6/2.8AF, BD SD01, Image 360

Stripping Dimensions

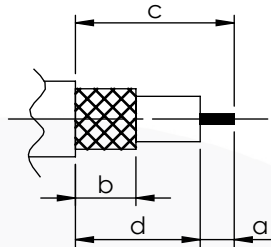

- a = 4.0 mm
- b = 8.0 mm
- c = 16.0 mm
- d = 12.0 mm

* CUT FOIL TO DIM. "b"

Assembly Procedure: AP019

Tooling

Centre Contact: SQ 0.95mm A/F Tool No: 96-HTS-75A

Crimp Sleeve: Hex 5.41mm A/F Tool No: 96-HTS-75A

Alignment Tool: Not Applicable Extraction: 96-2208

Environmental Specification

Operating Temp: -55 to +155 Deg C.

IP Rating (Mated): IP 64

Electrical Specification

Impedance: 75 Ohm

Frequency: 0-12 GHz

Dielectric W/V: 1500 Veff

Insulation res: 5000 M-Ohm

Mechanical Specification

Contact Retention: 15 N min

Cable Retention: 100 N min

Mating cycles: 500

Weight: 26.56 g

Connector Interface

image for illustration purposes only

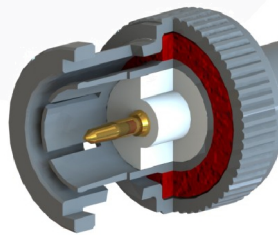

-22.25 dB @ 3.0 GHz

-18.25 dB @ 6.0 GHz

-18.95 dB @ 9.0 GHz

-19.17 dB @ 12.0 GHz

Return Loss Graph

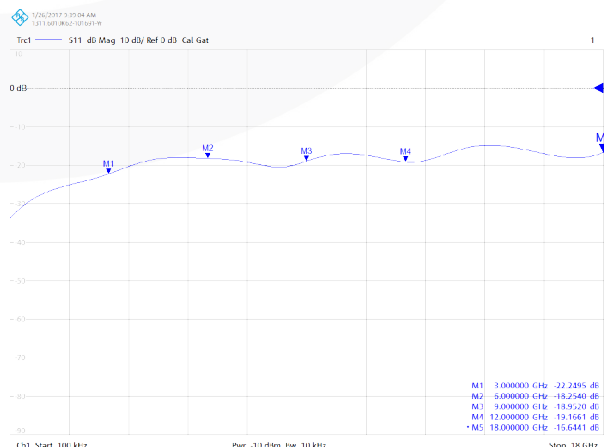

8	MALE CONTACT	BRASS	GOLD
7	WASHERS	SK5	NICKEL
6	COUPLING NUT	BRASS	BLACK NICKEL
5	GASKET	SILICONE	N/A
4	CRIMP SLEEVE	BRASS	NICKEL
3	INSULATOR	PTFE	N/A
2	CENTRE CONTACT	BERYLLIUM COPPER	GOLD
1	BODY	BRASS	GOLD
ITEM	DESCRIPTION	MATERIAL	PLATING

A4	SHEET 1 OF 1	DIMENSIONS ARE IN MILLIMETRES		
REVISION :	B01	NAME	SIGNATURE	DATE
ISSUE :	4	DRAWN	GE	22-Apr-15
		CHK'D	IG	22-Apr-15
		APP'V'D		
6-8 COLNE ROAD, TWICKENHAM, MIDDLESEX. TW1 4JR				
THE INFORMATION IS GIVEN AS AN INDICATION ONLY AND IS SUBJECT TO CHANGE WITHOUT NOTICE. IN THE CONTINUAL GOAL TO IMPROVE OUR PRODUCTS, WE RESERVE THE RIGHT TO MAKE ANY MODIFICATIONS NECESSARY WITHOUT PRIOR NOTICE.				