

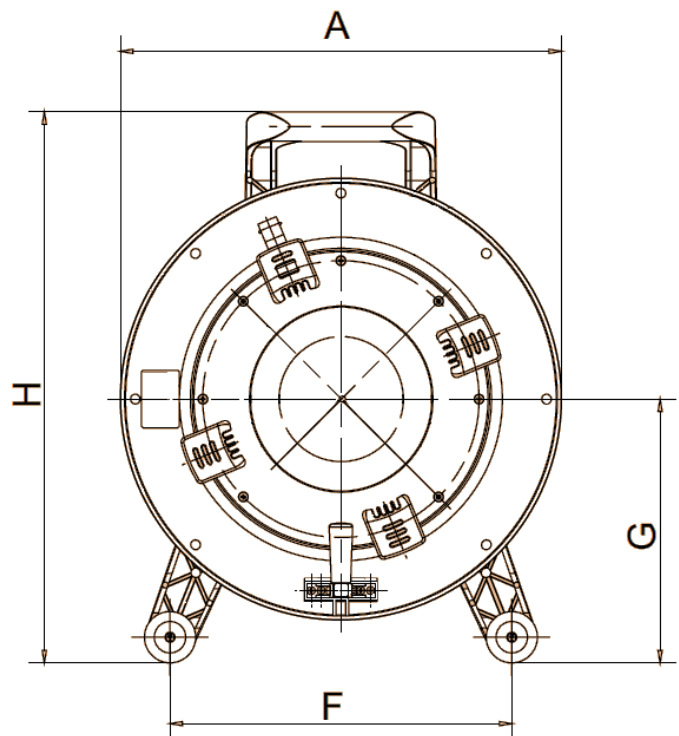

Black steel cable drum, with steel tube frame. Friction drum-brake incorporated into the frame to prevent movement in transit. Open hub plus four brackets on the flange face to enable the cable tail to be brought out from the hub of the drum at a gentle angle, (important for coaxial and essential for fibre cables), coiled and secured around the brackets. Folding winding-handle on the drum flange.

Dimensions & Weight

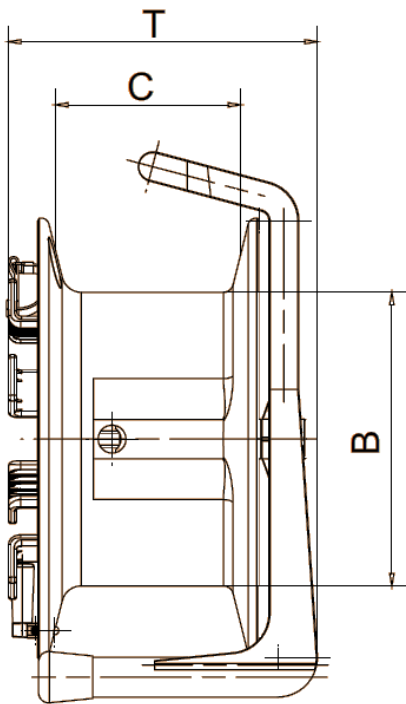

A	445mm	G	266mm
B	296mm	H	555mm
C	187mm	T	312mm
F	345mm		

Weight 6.7kg