



# CANFORD PPM DRIVE CARD

## 58-321 Canford PPM Drive Card Mono

### DESCRIPTION

This PPM drive card incorporates a micro controller to control the PPM characteristics and can be run from either a single or dual rail power supply and be driven from either balanced or unbalanced sources. Peak LED illuminates at PPM 6, if fitted. The frequency response has a roll-off above 16kHz and there is provision for an external meter and internal PPM SLOW mode.

Always observe handling precautions for ESD sensitive devices at all times.

### CONNECTIONS

- For balanced use connect input signal to pins 6 and 7. Connect screen to pin 8 for single rail or supply common for dual rail operation.
- For unbalanced use connect input signal to pin 6 and screen to pin 7. Also connect screen to supply common or pin 8 in single rail supply.
- Only one LED can be fitted directly.
- An external meter may be connected via pins 1 and 2 (see wiring diagram).
- Connect pin 3 to pin 4 to activate PPM SLOW mode.

(Refer to connection diagram fig. 1 on next page).

For optimal EMC performance, care must be taken with appropriate shielding of external connections and with grounding/routing of signal and control cables. Ideally, the assembled meters should be housed in screened cases and power supply common should be earthed as close as possible to the PCB. Ferrite rings may be used to improve performance in sensitive areas. In particular, any long cables to remote control switches and external meter should be via earthed screened cable. Ceramic de-coupling capacitors may be connected close to the PCB if necessary.

### POWER SUPPLIES

Power can be dual or single supply. Single 12-30VDC at 25mA is recommended as the ground plane is then 0V. This gives improvements in the EMC performance of the unit.

### CALIBRATION

Calibration of the drive is factory set to PPM4 at 0dBu. When fitting the meter to the card it may be necessary to adjust pot RV2, to compensate for the meter tolerance. After applying 1kHz tone at 0dBu, adjust RV2 to align the pointer with PPM 4. RV1, Input Gain control, should not need adjustment but the user may wish to alter the reference level for systems which are not at 0dBu.

### TECHNICAL SPECIFICATION

Indicating meter required to:	BS EN 6840: pt 10: 1991; IEC268-10
Input signal:	0dBu (+/- 3dBu)
Resolution of meter drive circuitry:	8 bit
Resolution of rectifier:	10 bit @+14dBu
Input impedance:	100kΩ (per leg) balanced
Frequency response:	20 - 16000Hz
Power supply requirements:	12-30V DC or 6V to 15V DC @ 25mA
Dimensions:	67 x 54mm
Weight:	25g



## CANFORD PPM DRIVE CARD

### PIN LAYOUTS

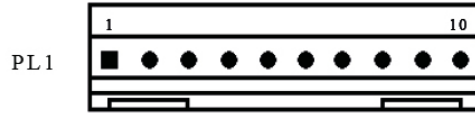

Connector viewed from component side.

1	External Meter	+ve
2	External Meter	-ve
3	Slow Mode Switch	
4	Common LED	-ve /Slow Mode Switch
5	Peak LED	+ve
6	Signal IN	+ve
7	Signal IN	-ve
8	Common	
9	Power Supply	+ve
10	Power Supply	0V/-ve

### PL1 WIRING

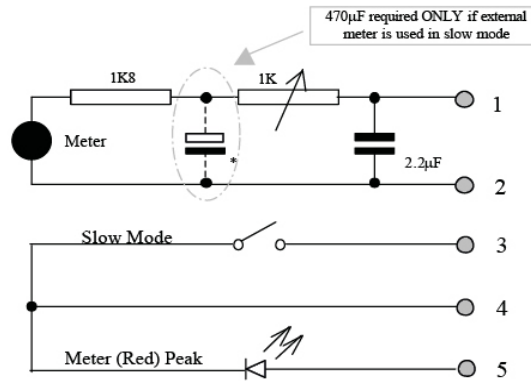

Balanced Input, Single Rail Power

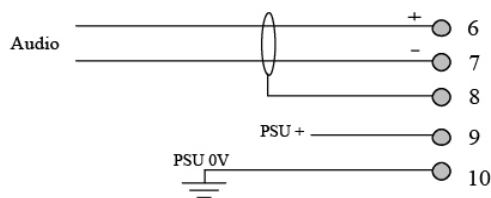

Un-balanced Input, Single Rail Power

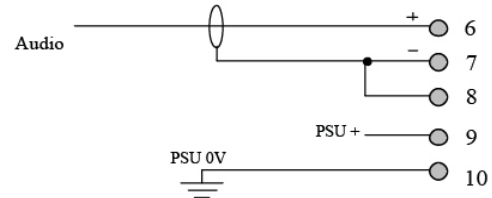

Balanced Input, Dual Rail Power

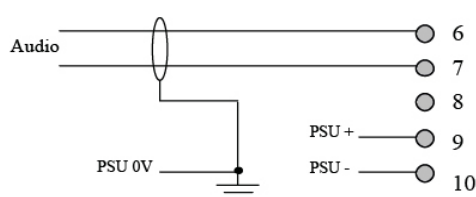

Un-balanced Input, Dual Rail Power

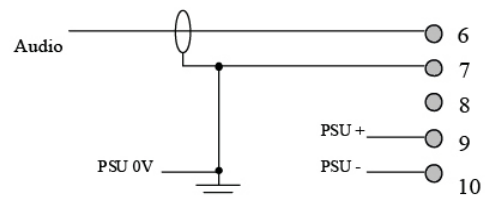

Fig. 1 – Meter, Audio & Power Connections



## CANFORD PPM DRIVE CARD

### COMPONENT LAYOUT

