

Speech Transfer System

Surface Mounted Entry System | STS-K009



Installation & User Guide

June 2020

Contents

Product Overview	3
Components	3
Installation Instructions	4
Amplifier Installation	5
Microphone & Speaker Installation	6
Hearing Loop Installation	7
Amplifier Setup	8
Using the System	10
Troubleshooting	12

Contacta has a policy of continuous product development, and therefore small specification changes may not be reflected in this manual. Images, labels, packaging, accessories and product colours are subject to change without notice.

Product Overview

This speech transfer system provides high quality sound across partitions and safety screens. It includes our surface mounted entry unit, our open duplex amplifier, a hearing loop, and a free-standing microphone and speaker unit for staff.

The surface mounted entry is for customer use and is installed at head height. A call button is on the front of the unit; when pressed, it alerts staff to a customer's presence and opens a conversation channel.

It is suitable for environments with low ambient noise.

Components

General Components

1. Installation and User Manual
2. Amplifier
3. Hearing Loop Sticker
4. IEC Lead
5. Power Supply
6. Hearing Loop Aerial
7. Mounting Bracket
8. Staff Microphone
9. Surface Mounted Entry Unit

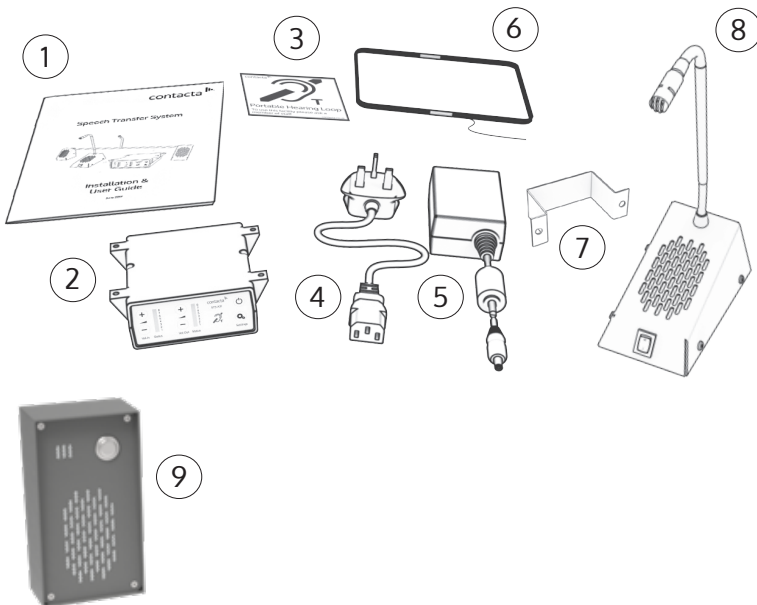

Installation Instructions

We recommend that installation is carried out by a qualified engineer, adhering to relevant standards.

Check the contents of the box to familiarise yourself with the components.

The staff microphone and amplifier should be installed on the staff side of the counter. The customer speaker and microphone kits should be installed on the customer side of the counter.

Follow all relevant instructions in the following order:

1. Amplifier Installation (see page 5).
1. Microphone & Speaker Installation (see page 6).
2. Hearing Loop Installation (see page 7).
3. Amplifier Setup (see page 8).
4. Using the System (see page 10).

Recommended Tools

A basic toolkit recommended to install the system will include:

- Screwdrivers (Flat or Blade 2.5mm and Phillips Head PH2)
- Battery or Mains Drill
- Drillbits: 2mm, 3mm, 5mm and 7mm
- Allen Key Set
- Cable Tacking Gun (10mm)
- Wire Cutters/Strippers
- Pliers
- Tape Measure
- Pencil or Marker Pen
- Cable Ties
- Electrical Insulation Tape
- Trunking

Amplifier Installation

Amplifier Installation

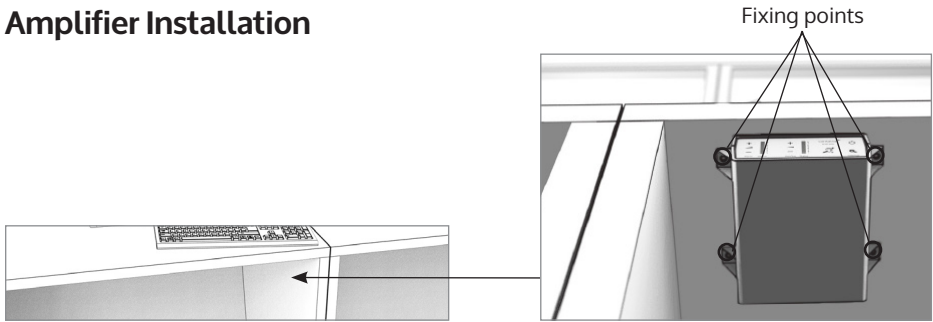

1. Place the amplifier under a staff counter, ensuring that it will not obstruct staff when they are sitting.
2. Mark the four fixing points for the amplifier under the counter.
3. Drill and fix the amplifier in place using the supplied screws.
4. Install the amplifier's power supply close to a power socket outlet using the supplied mounting bracket and fixing screws.

Amplifier Connections

After all relevant components have been installed, connect all green plugs to the sockets at the rear of the amplifier following the layout detailed below.

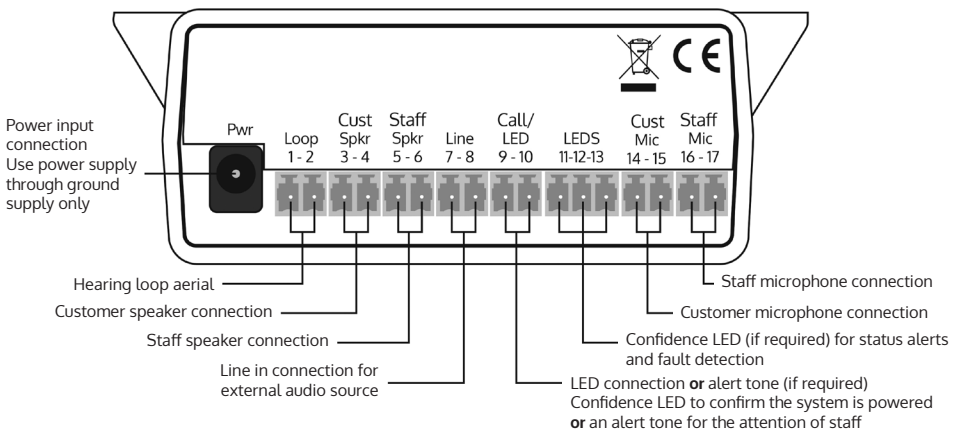

Microphone & Speaker Installation

1. Place the staff microphone on the staff side of the partition, ensuring that it does not cause an obstruction and is as close to staff as possible. It is ideally positioned no more than 300mm away from the staff member.

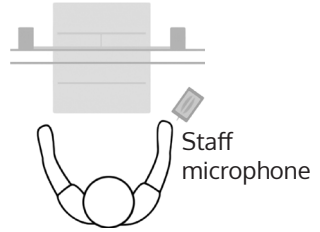

2. Use the cable management hole to run the staff microphone cable back to the amplifier. If there is not already a cable management hole, drill in a suitable location near the rear of the counter.
3. Find a suitable location for surface mounted entry unit. It is ideally be placed at head height (approximately 1.65m) from the ground to allow most customers to easily press and speak into it.
4. Mark the four fixing points for the surface mounted entry unit and drill the holes.

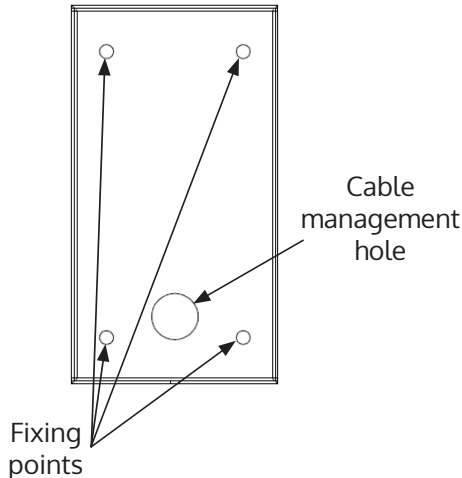

5. Secure the surface mounted entry unit to the surface using the screws provided.
6. Run the cables from the pods through through the surface.
7. Route all the cabling neatly to the amplifier location on the staff side.

Hearing Loop Installation

The aerial should be fixed under the desk-top or counter centrally on the customer side, one half mounted horizontally under the counter and the other half mounted vertically, facing the customer (as in the first scenario below).

Position the aerial under the counter using either the provided P-clips or another fixing method of your choice. See the diagram below for recommended positioning.

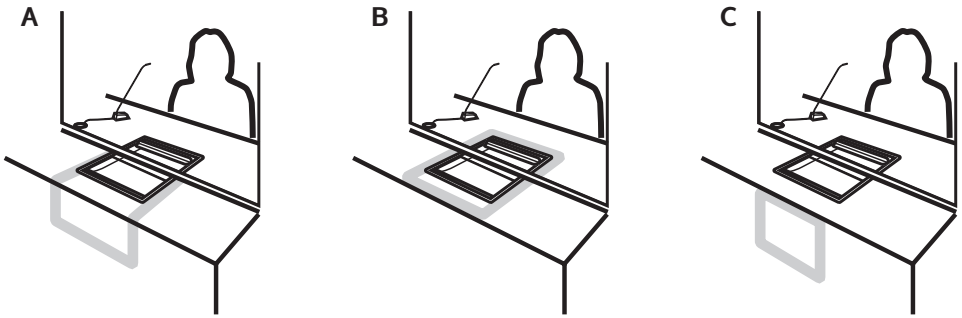

A is the optimum layout for a counter hearing loop.

B and C are acceptable only if A is not possible and the layout is aligned so that the magnetic field will be directed towards user's head heights.

Ensure all hearing loop signage is displayed clearly.

Amplifier Setup

Our amplifier provides full open duplex communication and is compatible with all of our speech transfer systems. It features individual displays for staff or customer adjustments and individual fault lights for easy fault diagnosis.

Overview of Front Panel Buttons

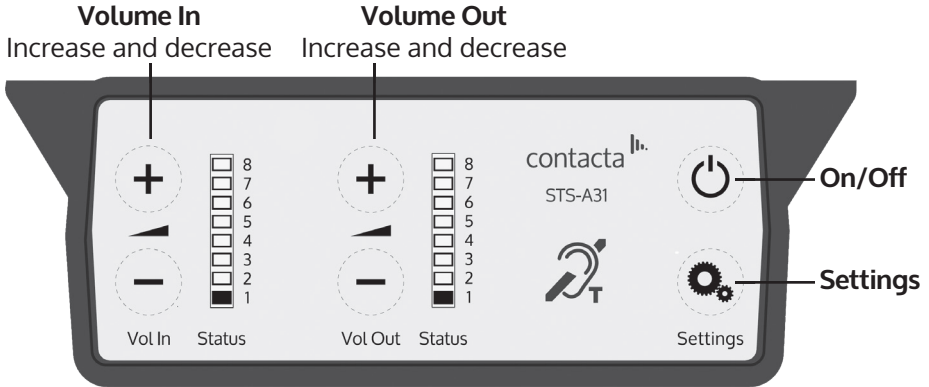

Engineer's Mode

Before entering engineers mode, cycle the power. To do this either:

- Switch the power off at the wall socket and back on again, or,
- Remove the power connector and re-insert it

To enter engineers mode, simultaneously press and release the following buttons within 20 seconds of cycling the power:

- Settings button
- Volume In increase button
- Volume Out increase button

The on/off and settings buttons in engineers mode operate as follows:



Move to the next setup area



Save and exit engineers mode

Please note:

- Save and exit engineers mode after making any adjustments.
- The amplifier will automatically exit engineers mode without saving if no buttons are pressed for 2 minutes.

Setup Areas

Whilst in engineers mode, there are 3 editable setup areas. You will always enter setup area 1 first. The green Volume In LED bar will flash to indicate which setup area you are in.

Setup Area 1: Maximum Volume Adjustment (LED 1 flashes)

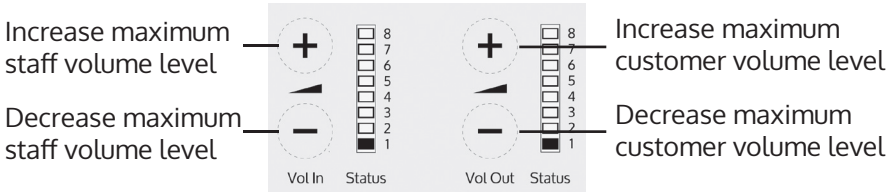

Setup Area 2: Ducking Adjustment (LED 2 flashes)

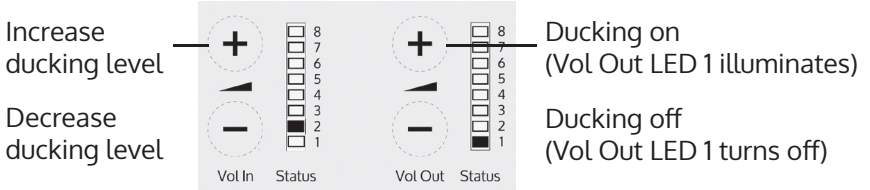

Setup Area 3: Hearing Loop Drive Adjustment (LED 3 flashes)

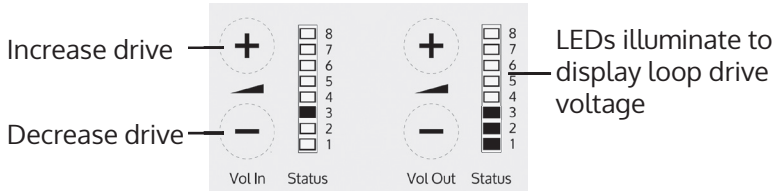

If the amplifier does not have a loop attached, turn off the red loop fault LED 8 by adjusting the drive down to off.

Please note: If the amplifier detects an error in its settings memory it will restore itself to factory default settings.

Using the System

When powered and in normal operational mode the amplifier will display Volume In LED 1 as steady green.

When the amplifier is switched off using the **On/Off button**, audio is muted and LEDs are not illuminated; press any button to turn the amplifier on again.

To adjust the **staff volume level**:

- Press and hold the Volume In (+) or (-) buttons to increase or decrease the level. The corresponding LED bar will show the volume setting.

To adjust the **customer volume level**:

- Press and hold the Volume Out (+) or (-) buttons to increase or decrease the level. The corresponding LED bar will show the volume setting.

For best possible performance:

1. Ensure the customer and staff volumes are turned completely down.
2. Adjust staff volume (Volume In) to a comfortable level.
3. Increase customer volume (Volume Out) until feedback is heard.
4. Decrease customer volume (Volume Out) until feedback is just eliminated. Check that the amplifier is fully functional by ensuring the red 'fault' light is NOT displaying.
5. If there is insufficient volume even after you have adjusted the volume controls, enter engineers mode and raise max volume settings. Exit engineers mode and repeat initial setup.
6. The system is now ready to use.

Fault Diagnosis LEDs

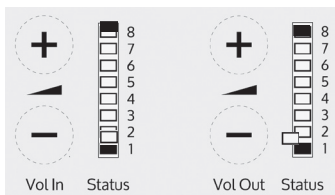

- Volume In LED 8 will stay red if there is a fault with the staff microphone.
- Volume Out LED 8 will stay red if there is a fault with the customer microphone.
- Volume In LED 8 will flash red if there is a fault with the loop (i.e. a broken aerial).

Factory Default Settings

To return the amplifier the factory default settings:

1. Unplug the power supply and then reconnect it.
2. Press the On/Off button and Volume In (-) button together, then release.
3. The Volume In LED bar will have all LEDs illuminated, while the Volume Out LED bar will display the firmware revision number in a fixed pattern of LEDs. This indicates that default settings have been restored.

Troubleshooting

Symptom	Possible Fault	Action
There is no power detected through the amplifier (and there is power at the socket).	1) Power jack not plugged in or faulty. 2) Plug fuse has blown. 3) Faulty power supply unit. 4) Faulty amplifier.	1) Check power jack is firmly plugged in. 2) Replace fuse. If it blows again, replace the power supply unit. 3) Replace the power supply unit. 4) Replace amplifier.
The red LED is illuminated on front panel.	1) Constant red LED: Staff or customer microphone fault. 2) Red LED comes on after speech: Induction loop fault.	1) Ensure microphone is wired correctly and firmly plugged in. Try alternative microphone to ensure port is working. 2) Ensure induction loop connector is wired correctly and firmly plugged in.
I can't hear audio through the induction loop.	1) Induction loop or microphone is disconnected. 2) Loop tester has a fault.	1) Check instructions for correct connections and, if possible, check the hearing device with a known working hearing loop. 2) Ensure loop tester has a new set of batteries.
I can hear interference through speakers (buzzing / whistling / hissing).	1) Unscreened or poorly earthed third party equipment is being used in close proximity. 2) Internal volume gain set to high. 3) Incorrect power supply being used.	1) Switch off any third party equipment to identify the source of interference. 2) Access the amplifier engineers mode to adjust the internal settings. 3) Ensure that our grounded power supply unit is connected.
Amplifier goes into feedback.	1) Internal volume gain set to high. 2) Microphone positioned too close to speaker.	1) Access the amplifier engineers mode to adjust the internal settings. 2) Move the microphone to a location further from the speaker.
Unit does not go into power saving mode.	1) Ambient noise in area is too high.	1) Switch off any air con systems, desktop fans and or computers to reduce ambient noise.

If no action is successful please seek assistance from your distributor or a Contacta installer.

contacta 

Contact your local
distributor for further
information.

www.contacta.co.uk