

Digital Wireless Receiver

Operating Instructions

DWR-S03D

DWX **WiDIF-HP**
DIGITAL WIRELESS  Cross Remote

Table of Contents

Features	3	Display of the audio signal delay time (SYSTEM DELAY)	16
Parts Identification	4	TX (Transmitter Virtual) 1/2 Menu	16
Preparation	6	Display of the transmitter's name (NAME)	16
Attaching DWA-SLAS1/SLAU1	6	Displaying of the audio attenuator setting (ATT)	16
Attaching to Sony camcorder	6	Display of the low-cut filter setting (LCF)	17
Using the DWA-01D/F01D wireless adapter	7	Lock function setting display (LOCK)	17
Setting the Receiving Channel	7	Display of the power save setting (POWER SAVE)	17
Selecting the band block	7	Display of audio input level (INPUT LEVEL) ...	17
Selecting the frequency band / group / channel	7	Display of the transmission power setting (RF POWER)	17
Setting the frequency directly	8	Display of the +48V power setting (+48V)	17
Using the automatic scan/sync function	8	Time display (TIME)	17
Using the active channel scan function	9	Display of battery level display settings (BATT REMAIN)	17
Using the clear channel scan function	9	Cross Remote (RF REMOTE)	17
Using the Encrypted Transmission Function	10	Using the Cross Remote	18
Using secure key mode (SECURE KEY)	10	Pairing with a transmitter	18
Using password mode (PASSWORD)	11	Changing the Settings on the Transmitter	19
Menu Displays and Detailed Settings	11	Group/channel setting (GP/CH)	19
Menu structure and hierarchy	11	Audio attenuator setting (ATT)	19
Basic menu operations	12	Low-cut filter setting (LCF)	19
UTILITY Menu	13	Lock function setting (LOCK)	19
Selecting the band block	13	Power-saving setting (POWER SAVE)	20
Audio output setting (AUDIO OUTPUT)	13	Setting the audio input level (INPUT LEVEL) ...	20
Selecting the AES/EBU output reference level (AES/EBU LVL@MIC)	13	Transmission power setting (RF POWER)	20
Selecting the sync signal (SYNC SOURCE)	13	+48V power setting (+48V)	20
Terminating the sync signal (WORD SYNC 75ohm)	13	Battery level display setting (BATT REMAIN)	20
Selecting output 1 (ANALOG OUTPUT1)	13	Block Diagram	21
Automatic scan/sync function (AUTO SCAN/SYNC)	14	Troubleshooting	22
Showing the accumulated use time (TIME)	14	Important Notes on Operation	24
Setting the brightness of the display (BRIGHTNESS)	14	Notes on using the receiver	24
Automatic dimming of the display (DIMMER MODE)	14	On cleaning	24
Setting memory function (USER MEMORY) ...	14	Transmitter software version	24
Resetting parameters to their factory settings (FACTORY PRESET)	14	Audio degradation due to weak reception	24
Displaying the software version (VERSION) ...	14	Specifications	25
RX (tuner) 1/2 Menu	15	Carrier Frequencies and Channel Steps	27
Group/channel selection (GP/CH)	15		
Frequency band selection (BAND)	15		
Direct frequency input function (FREQ INPUT)	15		
Active channel scanning function (ACT CH SCAN)	15		
Clear channel scan function (CLR CH SCAN) ...	15		
Transmitter search function (SEARCH TX)	15		
Using the RF squelch function (RF SQUELCH)	15		
Encrypted transmission function (ENCRYPTION)	15		
Setting the audio codec mode (CODEC MODE)	16		

Features

The DWR-S03D digital wireless receiver is a slot-in type wireless receiver capable of receiving two channels from digital wireless transmitters. When combined with the separately-sold DWA-SLAS1/SLAU1 digital wireless adapter for use with a Sony commercial camcorder, DWA-01D/F01D, or UniSlot®* standard device, the DWR-S03D makes it possible to build a fully digital ENG/EFP audio system.

This receiver enables the application of multiple channels over unused television channels through the use of the built-in Sony original channel plan.

* UniSlot® is a registered trademark of Ikegami Tsushinki Co., Ltd.

What is DWX?

DWX refers to Sony's new digital wireless microphone system. The DWX series reflects Sony's extensive expertise in professional microphones and sound design. It represents a successful blend of Sony know-how, wireless technology renowned for stability, and cutting-edge digital audio technology.

In addition to realizing the high sound quality possible with a digital system, the DWX series supports multi-channel simultaneous operation, encrypted transmission, and metadata transmission for monitoring the status of multiple transmitters. Using a main link and a separate additional link, remote control of transmitters from the receiver is also possible. With its many advanced features, the system has the potential to revolutionize the workflow of professional applications.

What is WiDIF-HP?

WiDIF-HP (WiDIF: Wireless Digital Interface Format, HP: High Profile) is a wireless digital audio interface format developed by Sony.

It enables highly secure transmission with high sound quality and low system latency, and supports simultaneous multi-channel operation.

What is Cross Remote?

Cross Remote is a system that allows transmitters to be monitored and controlled from a receiver and the Wireless Studio control software installed on a computer connected to the receiver.

For example, the settings of a transmitter worn under clothing can be easily changed over the wireless link.

Digital audio ENG system

Attaching a compatible slot-in type camcorder to this device makes it possible to build a full digital audio ENG system.

Even incompatible camcorders with AES/EBU input terminals can use wireless adapter DWA-01D/F01D (sold separately) for a digital connection.

Flexible interface

The following digital wireless adapter can be used for flexible operation with various devices.

DWA-SLAS1: For connection with Sony brand camcorders, DWA-01D, DWA-F01D

DWA-SLAU1: For connection with UniSlot® standard devices

Multi-channel simultaneous operation

A 375 kHz step channel plan makes multi-channel simultaneous operation possible.

Automatic scan sync function

The DWR-S03D is equipped with an automatic scan sync function that enables quick, simple, configuration of safe frequency channels. Pressing the MENU SELECT and SET button simultaneously activates a shortcut for easy access. A frequency scan finds empty channels, setting the top two empty channels to both channels on the receiver and two paired transmitters via Cross Remote.

Stable RF transmission

The X-Dimension Diversity reception system* and high dynamic range RF circuits enable stable RF transmission.

* This is a Sony-original advanced diversity method that uses enhanced Sony digital technology and high-precision calculation algorithms to enable a combination of diversities from multiple different dimensions for dramatically improved transmission stability.

Function coordination with the XDCAM shoulder cam

The following features are available when pairing the DWR-S03D and Sony XDCAM shoulder cam.

- Audio delay due to digital wireless transmission is reduced to zero during recording by synchronizing audio with video on the camcorder.
- Wireless system status, such as the RF reception level, is displayed on the camcorder LCD and in the viewfinder.
- Various transmitter settings can be controlled from the camcorder via Cross Remote.
- The transmitter power save mode is remotely controlled* via the camcorder assignable switch.
- The transmitter power save mode is remotely controlled* automatically when the camcorder power switch is turned on/off.

* See the Sony website for detailed information on camera devices that support this feature.

Encrypted transmission

AES256 bit encrypted wireless transmission is possible for secure confidentiality.

User-set memory function

Various settings can be saved to the transmitter for easy activation.

Compact, lightweight, tough design

A magnesium die-cast and aluminum housing make the unit compact and lightweight. This makes for a balanced construction when installed on the camcorder. Because this item is expected to be used outdoors, it features a tough, dust-resistant construction with level II equivalent* splash-resistant performance.

* To ensure sufficient splash-resistant performance, use all mounting screws to securely attach the receiver to other devices.

Easy-to-see, full dot-matrix OLED (Organic Light-Emitting Diode) display

The quick response of the OLED display enables real-time operating conditions to be displayed clearly and accurately.

Camcorder rear mount

Using the DWA-01D digital wireless adapter (sold separately) makes it possible to mount the transmitter on the rear of a shoulder camcorder. Using a camcorder with an AES/EBU input terminal makes full digital audio recording possible. Also, using two receivers enables four-channel wireless microphone operation.

Parts Identification

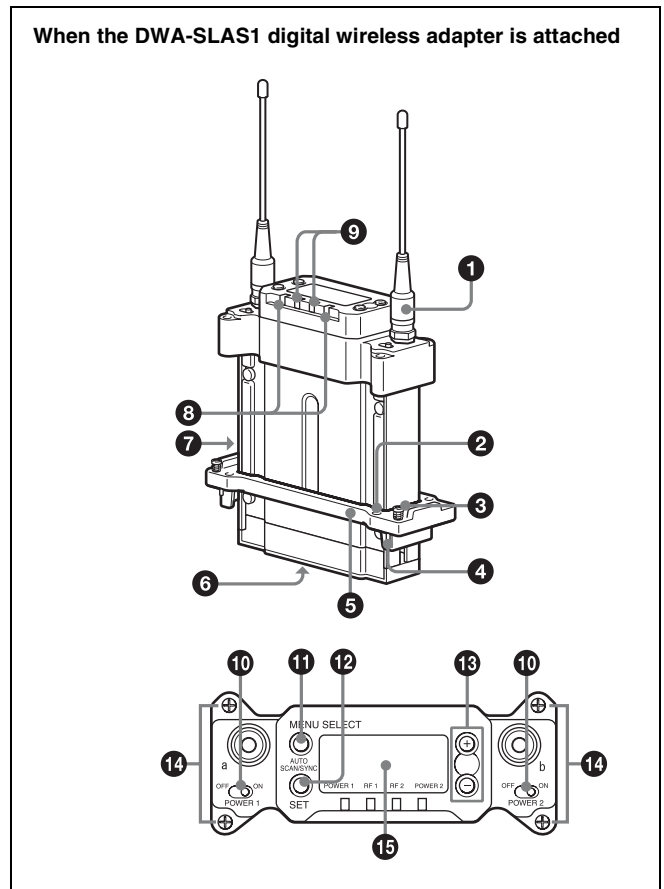

1 Antenna and antenna connector (SMA type)

Connect the supplied antenna here.

2 Bracket attachment screw hole

This is used to attach the bracket included with the DWA-SLAS1/SLAU1 digital wireless adapter (sold separately).

The attachment screws are included with the DWA-SLAS1/SLAU1.

3 Slot attachment screw

These screws are attached to the bracket included with the DWA-SLAS1/SLAU1 digital wireless adapter (sold separately) and are used to attach the camcorder or DWA-01D/F01D wireless adapter.

4 Compatibility pin (Only when attached DWA-SLAS1)

Prevents the attachment of an incompatible camcorder or adapter.

5 Bracket

This is supplied with the digital wireless adapter.

6 Slot connector

Use to connect the receiver to a camcorder or DWA-01D/F01D wireless adapter. Power, audio, and control signals are sent through this connector.

7 USB connector

Used to update the software.

Note

This is used only to update the software. Do not connect peripheral devices or a USB cable to this connector for any other reason.

8 POWER indicator

Lights up green when the power is on.

The POWER1 and POWER2 indicators indicate the power status of tuner 1 and tuner 2, respectively.

9 RF (radio frequency) indicators

Indicate the RF input level of tuner 1 and tuner 2.

The indicators that light up depend on the RF squelch function setting as follows:

When the RF (radio frequency) squelch level is set to OFF:

On in green: 25 dB μ or more

On in red: 20 dB μ to 25 dB μ

Off: Less than 20 dB μ

When the RF (radio frequency) squelch level is set to 20 dB μ :

On in green: 30 dB μ or more

On in red: 20 dB μ to 30 dB μ

Off: Less than 20 dB μ

10 POWER switches

Turn tuner 1 and tuner 2 on or off individually.

11 MENU SELECT (menu selection) button

Selects the displayed menu.

12 SET button

Changes the item to be set or enters the selected function or parameter value.

Shortcut function

Pressing the MENU SELECT and SET button simultaneously during operation activates the AUTO SCAN/SYNC function.

For details, see "Using the automatic scan/sync function" on page 8

13 + or – button

Use to select a function or value.

Shortcut function

Simultaneously press the + and – buttons during operation to activate the SEARCH TX function.

If you set the POWER switch on tuner 1 or tuner 2 to ON while holding down the + button, the tuner that you turned ON will begin the scanning operation of the clear channel scan function.

If you set the POWER switch on tuner 1 or tuner 2 to ON while holding down the – button, the tuner that you turned

ON will begin the pairing operation of the wireless remote control function.

14 Bracket mounting screws

These screws are included with the DWA-SLAS1/SLAU1 digital wireless adapter (sold separately), and is used to secure the bracket to the receiver.

15 Display section

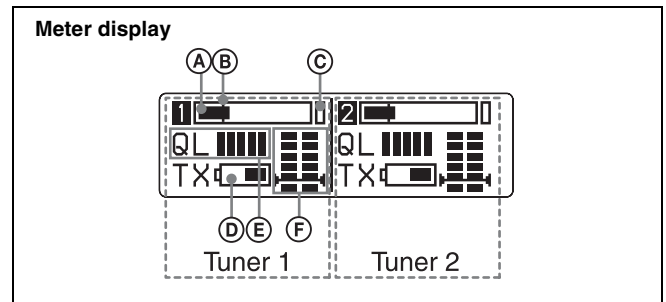

A Audio input level meter

Indicates the input signal level.

B Reference level gage

Indicates the reference input level.

–58 dBu (–60 dBV) is indicated when the input level is set to “MIC” on the transmitter, and +4 dBu when the input level is set to line.

C Peak indicator

Warns of excessive input by lighting up when the signal is 3 dB below the level at which distortion begins.

D Battery indication

The transmitter battery level is displayed using received metadata.

The display content differs according to the transmitter model and settings.

For details on replacing the transmitter batteries, see the transmitter operating instructions.

E Signal quality level meter

Indicates the quality of the RF signal reception.

The occurrence of many data errors during a given interval reduces the height of the bar graph.

This meter allows you to monitor signal deterioration that may occur when there is noise or when the transmitter is too far from the receiver.

F RF level meter

Indicates the RF input level. The number of segments that light up depends on the input level.

When the squelch function is set, the squelch level is indicated on the RF level meter.

When the RF input level drops below the squelch level, the output signal is muted.

Preparation

The separately-sold DWA-SLAS1 or DWA-SLAU1 digital wireless adapter is required to use this device.

DWA-SLAS1: This is used to connect a Sony camcorder, DWA-01D/F01D wireless adapter, or other Sony devices.

DWA-SLAU1: Used when connected to a UniSlot® standard device.

Attaching DWA-SLAS1/SLAU1

This section uses the DWA-SLAS1 drawing for explanations, but the DWA-SLAU1 can be attached using the same procedure.

Attaching the bracket

Attach the bracket included with the DWA-SLAS1/SLAU1 to the receiver.

- 1 Align the front of the receiver (surface with text) with the printed side of the bracket included with the DWA-SLAS1/SLAU1, then pass the bracket through the bottom of the receiver.

Pass the bracket through the receiver so that the slot attachment screw attached to the bracket faces upward.

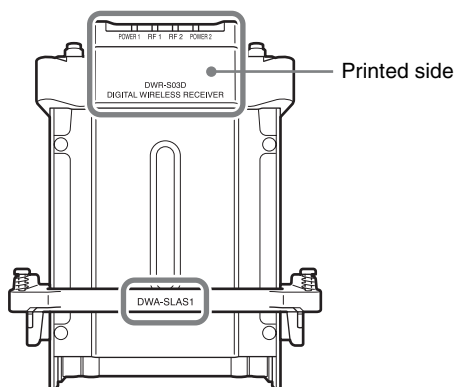

- 2 Use the screws included with the DWA-SLAS1/SLAU1 to secure the bracket to the receiver.

Use four screws on the DWA-SLAS1 and two screws on the bracket mounting screw hole to secure the accessories on the receiver.

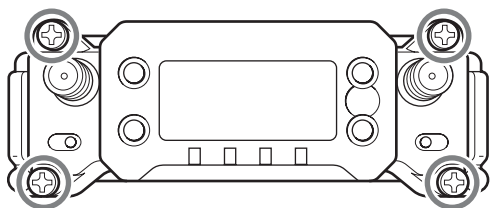

Attaching the DWA-SLAS1/SLAU1 main unit

- 1 Align the slot connector on the bottom of the receiver and the DWA-SLAS1/SLAU1 receiver connector, then insert the DWA-SLAS1/SLAU1 into the receiver.

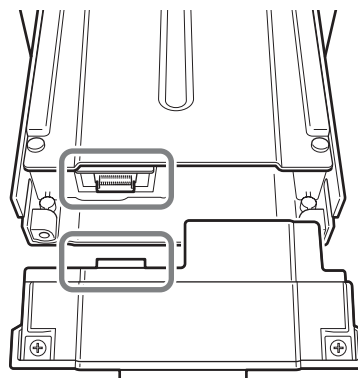

Notes

- Make sure there are no foreign objects in the terminals before connecting the devices.
 - Applying excessive force can damage the terminals, so take adequate caution.
- 2 Use the two screws attached to the bottom of the DWA-SLAS1/SLAU1 main unit to secure it to the receiver.

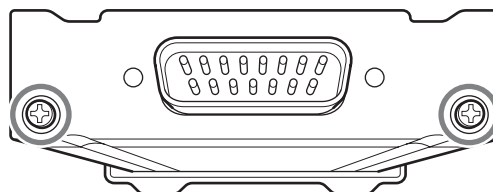

Attaching to Sony camcorder

The DWA-SLAS1 digital wireless adapter (sold separately) main unit can be attached to the wireless receiver slot of compatible Sony camcorders. The audio signal, which is converted to digital by the digital wireless transmitter, can be recorded as is to the camcorder, allowing you to create a fully digital system.

- 1 Remove the cover from the slot for the wireless receiver on the camcorder, and insert the receiver into the slot.

To avoid inserting the receiver in the wrong direction, confirm the location of the mounting screws and compatibility pin before inserting the wireless receiver.

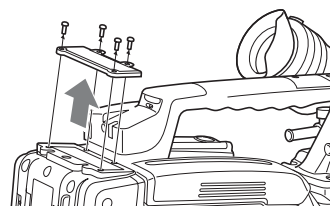

- 2 After inserting the receiver completely into slot, securely fasten the four mounting screws.

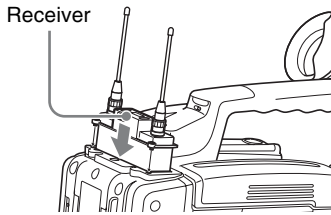

For details about operating the camcorder with the receiver, refer to the operating instructions supplied with the camcorder.

Notes

- Make sure to attach DWA-SLAS1 (sold separately) when connecting Sony devices.
- When connecting non-Sony devices using DWA-SLAU1 (sold separately), refer to the attachment instructions of the applicable device.
- If the camcorder is not compatible with the receiver, the compatibility pin on the receiver will make it impossible to insert the receiver into the slot.

For details on compatible camcorders, consult a Sony sales representative.

Using the DWA-01D/F01D wireless adapter

Attaching the receiver to the DWA-01D/F01D wireless adapter allows them to be used as a portable wireless receiver.

For details, refer to the operating instructions supplied with the adapter.

Setting the Receiving Channel

The receiver provides groups of channels for interference-free transmission. When using multiple wireless microphones and transmitters (simultaneous multi-channel operations) within the same area, selecting the same group and using a channel within that group can prevent signal interference.

Selecting the band block

This receiver is capable of wide band reception. Before setting the frequency band, group, or channel, set the band block.

Use the following procedures to set the band block.

- 1 Press the MENU SELECT button repeatedly until the UTILITY menu (meter indication) is displayed.
- 2 Press the + or – button repeatedly until the BAND BLOCK indication is displayed.
- 3 Hold down the SET button until the item to be set flashes.
- 4 Press the + or – button repeatedly to select BAND BLOCK.
- 5 Press the SET button to enter the setting.

Selecting the frequency band / group / channel

Set the frequency band (BAND), group (GP), and channel (CH) as follows.

For details on the groups and channels included in each frequency band, refer to the frequency lists.

For details on menu operations, see “Basic menu operations” on page 12.

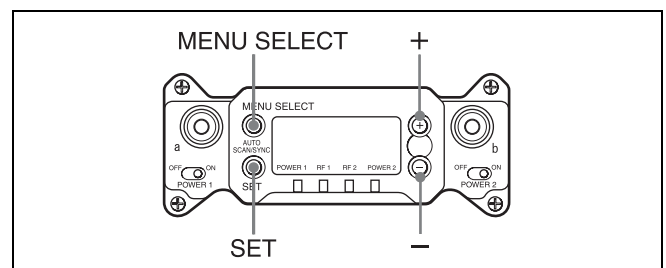

- 1 Press the MENU SELECT button repeatedly until the RX1/RX2 menu is displayed.

- 2 Press the + or – button repeatedly until the BAND screen is displayed.
- 3 Hold down the SET button until the item to be set flashes.
- 4 Press the + or – button repeatedly to select a frequency band.
- 5 Press the SET button to confirm the selection.
- 6 Press the + or – button repeatedly until the GP/CH screen is displayed.
- 7 Hold down the SET button until the item to be set flashes.
- 8 Press the + or – button repeatedly to select a group.
- 9 Press the SET button to confirm the selection.
The channel indicator starts flashing.
- 10 Press the + or – button repeatedly to select a channel.
- 11 Press the SET button to confirm the selection.

When the wireless remote control function is operating:

When you change the BAND/GP/CH setting on the receiver, you can send the BAND/GP/CH setting to the transmitter that is paired with the receiver.

Note

If the receiving channel (CH) configured on the receiver is a channel for which use with the wireless remote control function is restricted on the transmitter side, the UNMATCH screen appears.

In such cases, change the receiving channel on the receiver. If you want to use the restricted channel, set REMOTE to OFF in the transmitter's menu to release the channel restriction, and manually configure the transmitter's channel.

About use of the same group and channel by adjacent systems

When the same group and channel are being used by two or more systems that are within sight of each other and are separated without partitions or obstacles in wide open place, each system should be at least 100 meters away from the others to avoid interference.

Setting the frequency directly

Within the range of currently configured band block, the frequency can be set directly. Select the value of each digit using the +, –, and SET buttons.

- 1 Press the MENU SELECT button repeatedly until the RX1/RX2 menu is displayed.

- 2 Press the + or – button repeatedly until the FREQ INPUT screen is displayed.
- 3 Press and hold down the SET button.
The currently configured frequency is displayed.
- 4 On the FREQ INPUT screen, press the + or – button to set each digit of the frequency to set.
- 5 Press the SET button to confirm each digit.
Entry of the next digit is enabled.
- 6 After the last digit, press the SET button to confirm the receiver frequency.
The final two digits can be set to 00/25/50/75.

Notes

- Within the selected band block, the channel in the group (GP) with the smallest step (25 kHz or 125 kHz) is selected automatically.
- If a transmitter has been paired, a confirmation screen appears prompting you whether to also change the transmitter frequency. Select YES to also change the transmitter frequency.

Using the automatic scan/sync function

This function automatically searches for and sets a channel that does not have a signal and is not being used by other wireless devices.

Using the function automatically sets the two channels with the least interference to tuner 1/2.

If the wireless remote control feature is operating, automatically activate SLEEP on the transmitter before scanning or automatically set the reception channel configured after the scan to the transmitter, then automatically set it to ACTIVE.

Other than the following steps, the automatic scan/sync function can be activated by pressing the MENU SELECT button and SET button simultaneously while the receiver is on.

- 1 Press the MENU SELECT button repeatedly until the UTILITY menu is displayed.
- 2 Press the + or – button repeatedly until the AUTO SCAN/SYNC indication is displayed.
- 3 Hold down the SET button until the item to be set flashes.
- 4 In the AUTO SCAN/SYNC indication, press the + or – button repeatedly to select YES.

If there is a tuner whose wireless remote control function is not operating even though the power is on, a confirmation screen appears asking whether or not to continue scanning with the corresponding TX number.

Select YES to continue using the scan function and press the SET button to begin scanning.

If the wireless remote control function is operating on all tuners that are powered on, a confirmation screen does not appear, the transmitter is automatically set to SLEEP, and scanning begins.

When all BANDS have been scanned, the scan function is terminated.

- 5 Check the detected frequency candidate and press the SET button.

Detected candidate reception channels (CH) and frequencies are displayed alternately. Check the displayed candidates and press the SET button to finish. This operation does not confirm the channel.

- 6 To use a confirmed channel, check that it is displayed on the configured tuner or transmitter, then press the SET button.

If the wireless remote control function is operating, the transmitter GP/CH are also automatically set and SLEEP is canceled.

If you want to use the empty channel of another BAND, press the + or – button to select ANOTHER BAND, then press the SET button and go back to step 5.

Notes

- If the power is on for both tuner 1 and 2, the band set on tuner 1 is used for scanning. The same band as on tuner 1 is also used on tuner 2. If you would like to set different bands on tuner 1 and 2, turn only one tuner on and use automatic scan/sync.
- The group that initiates a scan in this function is fixed, and cannot be changed.
- If the receiving channel (CH) configured on the receiver is a channel for which use with the wireless remote control function is restricted on the transmitter side, the UNMATCH screen appears. In such cases, change the receiving channel on the receiver. If you want to use the restricted channel, set REMOTE to OFF in the transmitter's menu to release the channel restriction, and manually configure the transmitter's channel.

Using the active channel scan function

This function scans for a Sony digital wireless frequency from the frequency lists within the GP (group) selected during the GP/CH selection function.

Required condition for the detection:

- Sony digital wireless signal
- Above the RF squelch level of the receiver

- The setting of the encrypted transmission function is correct
- The audio codec mode settings match

- 1 Press the MENU SELECT button repeatedly until the RX1/RX2 menu is displayed.

- 2 Press the + or – button repeatedly until the ACT CH SCAN indication is displayed.

- 3 Hold down the SET button until the item to be set flashes.

- 4 Press the + or – button repeatedly to select YES.

Scanning starts. When a Sony digital wireless frequency is detected, scanning stops and the frequency is displayed. If you select NO, the scanning function will be cancelled.

- 5 If you decide on that frequency after checking it out, press the + or – button repeatedly to select SET, and then press the SET button.

To search for another frequency, press the + or – button repeatedly to select CONTINUE, and then press the SET button.

Note

If a Sony digital wireless frequency within the group is not found by the second try, scanning is cancelled.

Using the clear channel scan function

This function searches for a channel that is not being used by another wireless device or by a TV station. This function makes it easy to find an available channel to allow the wireless microphone to be used without interference. The function searches for an empty channel among the registered frequencies within the GP (group) selected by the GP/CH selection function.

In addition to using the following procedure, you can also set the POWER switch on tuner 1 or tuner 2 to ON while holding down the + button to start the clear channel scan function on the tuner that you turned ON.

- 1 Press the MENU SELECT button repeatedly until the RX1/RX2 menu is displayed.

- 2 Press the + or – button repeatedly until the CLR CH SCAN indication is displayed.

- 3 Hold down the SET button until the item to be set flashes.

- 4 In the CLR CH SCAN indication, press the + or – button repeatedly to select YES.

Scanning starts. When an empty channel is detected, scanning stops and the frequency is displayed.

If you select NO, the scanning function will be cancelled.

- 5** If you decide to use that channel, press the + or – button repeatedly to select SET, and then press the SET button.

When the wireless remote control function is operating, the group/channel setting can be sent to the transmitter.

To search for another empty channel, press the + or – button repeatedly to select SCAN AGAIN, and then press the SET button.

Note

If the receiving channel (CH) configured on the receiver is a channel for which use with the wireless remote control function is restricted on the transmitter side, the UNMATCH screen appears.

In such cases, change the receiving channel on the receiver. If you want to use the restricted channel, set REMOTE to OFF in the transmitter's menu to release the channel restriction, and manually configure the transmitter's channel.

Using the Encrypted Transmission Function

This receiver is capable of receiving scrambled signals from Sony digital wireless transmitters. This function prevents hacking of the signal.

To use this function, select one of the following encrypted transmission modes:

Encryption key modes (SECURE KEY / AES256):

An encryption key is automatically generated by the transmitter and used by both the transmitter and receiver in these one-to-one encrypted transmission modes.

The SECURE KEY mode is compatible with first and second generation DWX-series devices.

The AES256 mode uses AES 256-bit encryption for a higher level of security in transmissions.

Password mode: You choose a password of up to eight characters that can be set for multiple transmitters and receivers. This enables encrypted transmission to be conducted within a group.

Note

Make sure the same mode is set on the transmitter and receiver.

Using secure key mode (SECURE KEY)

Use this mode for one-to-one encrypted transmission between one transmitter and one receiver.

An encryption key that cannot be read from the outside is automatically generated by the transmitter. This key is transmitted to the receiver through the RF REMOTE function, enabling encrypted transmission to take place.

The encryption key used by the transmitter and receiver is newly generated for each key transmission, resulting in highly secure communication.

The encryption key used between the transmitter and the receiver is saved when the power is turned off, so the encrypted transmission can be resumed the next time the power is turned on.

1 Preparing the receiver (this unit)

- ① With the ENCRYPTION indication on (in the RX1/2 menu), hold down the SET button until the item to be set flashes.
- ② Press the + or – button repeatedly to select SECURE KEY or AES256, and then press the SET button.

2 Preparing the transmitter

Set SECURE KEY or AES256 on the transmitter that will transfer the encryption key.

For details on transmitter operations, refer to the operating instructions supplied with the transmitter.

3 Exchanging the encryption key

On the receiver, select REMOTE (wireless remote) as the method for encryption key exchange.

When the RF REMOTE function is off, REMOTE cannot be selected.

Note

If the transmitter does not support AES256, select SECURE KEY.

For details, check the operating instructions included with the transmitter you want to pair with the receiver.

The receiver searches for a transmitter that it has been paired with. After the receiver detects the transmitter, the transmitter exchanges the encryption key with the receiver and encrypted transmission begins.

Using password mode (PASSWORD)

Set this mode when multiple transmitters are paired with multiple receivers for encrypted transmission.

If the transmitters and receivers are set with the same user-designated password, the audio signal can be decoded.

This mode is useful when multiple transmitters and receivers are used as a single group, or when the audio signal from one transmitter is received by multiple receivers at the same time.

- 1 With the ENCRYPTION indication on (in the RX1/2 menu), hold down the SET button until the item to be set flashes.
- 2 Press the + or – button repeatedly to select PASSWORD, and then press the SET button.
- 3 Enter a password of up to 8 characters on the receiver.
+: The first press on the + button displays the character set. You can then use the + and – buttons to select the desired character. And then, pressing the SET button adds the selected character to the end of the current password.
–: Deletes the last character in the current password.
SET: Enters the character or edited password.
- 4 Set the encrypted transmission function on the transmitter to PASSWORD.
- 5 On the transmitter, set the same password that was set on the receiver.

For details on transmitter operations, refer to the operating instructions supplied with the transmitter.

Note

It is recommended that you change the password periodically.

Menu Displays and Detailed Settings

Menu structure and hierarchy

Menu structure

The receiver has 3 kinds of menu, as follows:

UTILITY menu

A menu that includes meter indications, functions used in combination with the DWA-01D/F01D wireless adapter and DWA-SLAU1, and settings for the organic light-emitting diode display.

RX1/RX2 (tuner 1/2) menu

A menu that includes tuner setting functions.

TX1/TX2 (virtual transmitter 1/2) menu

A menu that allows you to check the settings on the transmitter currently in communication with the receiver (tuner 1 or tuner 2).

Menu hierarchy

MENU SELECT

UTILITY	<ul style="list-style-type: none"> Meter indication BAND BLOCK AUDIO OUTPUT AES/EBU LVL@MIC SYNC SOURCE WORD SYNC 75ohm ANALOG OUTPUT 1 AUTO SCAN/SYNC TIME BRIGHTNESS DIMMER MODE USER MEMORY FACTORY PRESET VERSION
RX1	<ul style="list-style-type: none"> GP/CH BAND FREQ INPUT ACT CH SCAN CLR CH SCAN SEARCH TX RF SQUELCH ENCRYPTION CODEC MODE SYSTEM DELAY
TX1	<ul style="list-style-type: none"> NAME ATT LCF LOCK POWER SAVE INPUT LEVEL RF POWER +48V TIME BATT REMAIN RF REMOTE
RX2	<ul style="list-style-type: none"> GP/CH BAND FREQ INPUT ACT CH SCAN CLR CH SCAN SEARCH TX RF SQUELCH ENCRYPTION CODEC MODE SYSTEM DELAY
TX2	<ul style="list-style-type: none"> NAME ATT LCF LOCK POWER SAVE INPUT LEVEL RF POWER +48V TIME BATT REMAIN RF REMOTE

To UTILITY menu

Basic menu operations

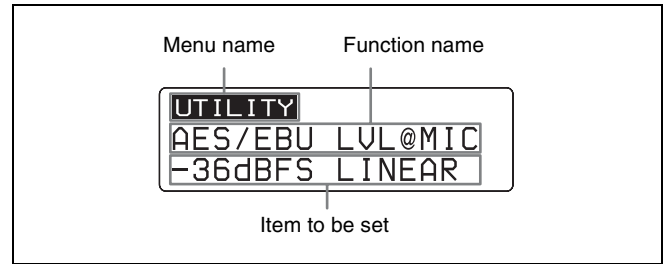

- 1 Press the MENU SELECT button repeatedly to select the menu.

Each time you press the MENU SELECT button, the menu changes in the following order:

UTILITY, RX1, TX1, RX2, TX2, UTILITY

- 2 Press the + or – button repeatedly until the function to be set appears.

Each time you press the + or – button, the item to be set changes.

For details, see “Menu hierarchy” on page 12.

- 3 Hold down the SET button until the item to be set flashes.

- 4 Press the + or – button to change the setting.

- 5 Press the SET button to enter the setting.

Note

When the tuner is turned off, the menus corresponding to that tuner are not displayed.

UTILITY Menu

For details on menu operation, see “Basic menu operations” on page 12.

The UTILITY menu includes items related to the basic receiver settings, including meter displays. These functions and parameters are explained here. Underlined items are the factory setting.

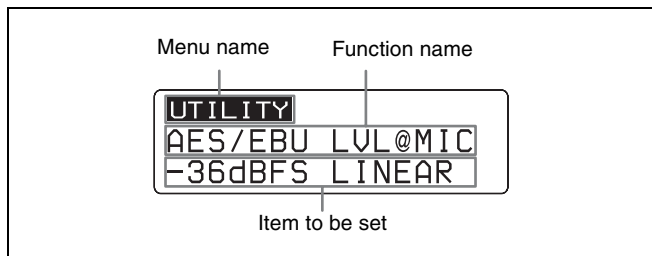

Note

The functions indicated by “ADAPTER” (SYNC SOURCE, WORD SYNC 75ohm, ANALOG OUTPUT1) in the upper-right corner of the display are functions used in conjunction with the optional DWA-01D/F01D wireless adapter.

Selecting the band block

Select the band block for reception.

See “Carrier Frequencies and Channel Steps” on page 27 for factory settings.

For details on the frequency bands included in each band block, refer to the frequency lists.

Note

Band block settings are enabled for both tuner 1 and 2. Tuner 1/2 band block cannot be set individually.

Audio output setting (AUDIO OUTPUT)

Sets whether the audio output is digital or analog when the DWA-SLAU1 is attached.

DIGITAL: Set to AES/EBU output.

ANALOG: Set to analog output.

Note

This menu item is displayed only when the DWA-SLAU1 is attached.

Selecting the AES/EBU output reference level (AES/EBU LVL@MIC)

Selects reference level for the AES/EBU output.

The setting of this function is invalid when the audio input level of the sending transmitter is set to LINE (–20 dBFS headroom signal).

Note

The function does not operate for analog output.

– 36 dBFS LINEAR: The audio signal from the transmitter is output with a headroom of 36 dB.

– 20 dBFS LIMITER: The reference level is changed to –20 dBFS in conformity with the normal AES/EBU interface and the audio signal from the transmitter is compressed.

– 20 dBFS ST LIMIT: The reference level is changed to –20 dBFS (as in the –20 dBFS LIMITER mode above) and audio signal compression is linked for tuner 1 and tuner 2. Select this setting when sending stereo audio signals using 2 transmitters.

Selecting the sync signal (SYNC SOURCE)

Selects the sync signal source for the receiver when it is attached through the optional DWA-01D/F01D wireless adapter. The receiver supports an external sync signal (word clock) of 32 kHz –6% to 96 kHz +6%.

For details on locking the sync signal, refer to the operating instructions supplied with the adapter.

INTERNAL: The internal sync signal (48 kHz) is used.

AUTO: The external sync signal is used on a priority basis. When there is no external sync signal input, the internal sync signal is used automatically. The currently selected sync signal is displayed “INTERNAL” or “EXTERNAL.”

EXTERNAL: Synchronization with an external word clock signal. The current synchronization status is displayed “UNLOCK” or “LOCK.”

Note

When “EXTERNAL” is selected, digital signals and analog signals will be output only if there is an external word clock signal input.

Terminating the sync signal (WORD SYNC 75ohm)

This function provides termination for the WORD SYNC connector on the DWA-01D/F01D wireless adapter.

ON: 75-ohm termination is added.

OFF: 75-ohm termination is not added.

Note

When the receiver is turned off, the termination is released.

Selecting output 1 (ANALOG OUTPUT1)

Selects the OUTPUT1 connector of the DWA-01D/F01D wireless adapter.

When the OUTPUT2 connector of the adapter is being used for AES/EBU output, the OUTPUT1 connector can be used for sub-output.

RX1: Outputs the audio signal received on tuner 1.

RX2: Outputs the audio signal received on tuner 2.

RX1+2: Mixes and outputs the audio signals received on tuners 1 and 2.

Automatic scan/sync function (AUTO SCAN/SYNC)

Run the automatic scan/sync function.

For details, see “Using the automatic scan/sync function” on page 8.

Showing the accumulated use time (TIME)

You can display the accumulated battery use time as a rough estimate of total receiver usage. The factory setting is “00:00”.

Resetting the accumulated time indication

1 Hold down the SET button until the time indication flashes.

2 Press the – button so “00:00 RESET” appears, and then press the SET button.

Setting the brightness of the display (BRIGHTNESS)

Ten levels of brightness can be selected for the organic light-emitting diode display.

The selectable settings are the following:

(Dark) **1 2 3 4 5 6 7 8 9 10** (Bright)

Automatic dimming of the display (DIMMER MODE)

The organic light-emitting diode display can be set to dim or turn off after a certain amount of time.

AUTO OFF: The display turns off after 30 seconds. The display goes on again when you press the SET, +, or – button.

AUTO DIMMER: The display dims after 30 seconds. The display becomes bright again when you press the SET, +, or – button.

ALWAYS ON: The display stays on at the brightness level set with the BRIGHTNESS function.

Setting memory function (USER MEMORY)

Various settings can be stored in the receiver and then loaded.

When you execute SAVE, the values for the following settings will be saved.

UTILITY menu

- BAND BLOCK
- AUDIO OUTPUT
- AES/EBU LVL@MIC
- SYNC SOURCE
- WORD SYNC 75ohm
- ANALOG OUTPUT 1
- BRIGHTNESS
- DIMMER MODE

RX1/RX2 menu

- GP/CH
- BAND
- RF SQUELCH
- ENCRYPTION
- CODEC MODE

Notes

- You cannot execute LOAD if you have never executed SAVE.
- If you execute LOAD while performing the following operations after setting values were stored, proper communication with the transmitter will not be possible. In such cases, perform pairing or encrypted transmission settings again.
 - Pairing the unit or establishing encrypted transmission with a different transmitter.
 - Pairing the transmitter that was paired with the unit with a different receiver.
 - Establishing encrypted transmission between the transmitter and a different receiver.

Resetting parameters to their factory settings (FACTORY PRESET)

All parameter settings can be returned to their factory settings.

Holding down the SET button until a message appears asking for confirmation. Press the + or – button repeatedly to select YES, and then press the SET button to enter. The receiver parameters are reset to their factory settings.

Displaying the software version (VERSION)

The version of the receiver software can be displayed.

RX (tuner) 1/2 Menu

For details on menu operation, see “Basic menu operations” on page 12.

Use this menu to set the digital wireless receiver functions (the main functions of this receiver). The following shows the US model display.

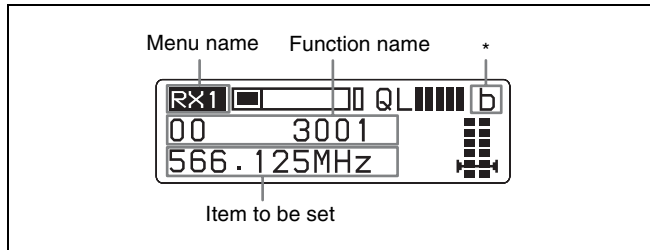

* The antenna currently selected by the diversity function is indicated by “a” or “b”.

Group/channel selection (GP/CH)

See “Carrier Frequencies and Channel Steps” on page 27 for factory settings.

For details, see “Selecting the frequency band / group / channel” on page 7.

Frequency band selection (BAND)

See “Carrier Frequencies and Channel Steps” on page 27 for factory settings.

For details on the groups and channels included in each frequency band, refer to the frequency lists.

Direct frequency input function (FREQ INPUT)

This function enables you to set the frequency directly by selecting preconfigured values.

For details on configuration, see “Setting the frequency directly” on page 8.

Active channel scanning function (ACT CH SCAN)

The active channel scan function operates.

For details, see “Using the active channel scan function” on page 9.

Clear channel scan function (CLR CH SCAN)

The clear channel scan function operates.

For details, see “Using the clear channel scan function” on page 9.

Transmitter search function (SEARCH TX)

This function enables quick searching for transmitters communicating with the receiver via Cross Remote. When a transmitter is found, the transmitter display responds by flashing.

Notes

- If the transmitter is not compatible with the transmitter search function, the transmitter will not respond.
- This function cannot be used if Cross Remote communication is not available, regardless of the audio reception status.

Searching for a transmitter

Hold down the SET button in the SEARCH TX screen, then press the SET button again when the “SEARCH?YES” display flashes.

You can also begin a transmitter search by pressing the + and – button simultaneously.

You can search for the selected transmitter by pressing the SET button after the display flashes when pressing the +/- buttons.

SEARCH TX1?: Search for a transmitter communicating via RX1 and Cross Remote

SEARCH TX2?: Search for a transmitter communicating via RX2 and Cross Remote

However, if the power is on for one tuner, the above selection screen is not displayed.

Using the RF squelch function (RF SQUELCH)

This function disables the audio when the RF signal becomes weak and the sound quality deteriorates. This prevents interference from a nearby Sony digital wireless transmitter set at the same frequency.

20 dBμ: Sets the squelch level to 20 dBμ.

OFF: The RF squelch function does not operate.

Encrypted transmission function (ENCRYPTION)

Set the parameters for the encrypted transmission function.

SECURE KEY: Sets the secure key compatible with the first generation and second generation DWX series.

AES256: Sets the AES256 secure key.

PASSWORD: Sets the password method.

OFF: The encrypted transmission function is not used.

For details, see “Using the Encrypted Transmission Function” on page 10.

Setting the audio codec mode (CODEC MODE)

Set the audio codec mode.

If there is a transmitter paired with this receiver, the audio codec mode of the transmitter is also switched at the same time.

MODE1: This audio codec mode is compatible with the first generation DWX series.

MODE2: This audio codec mode maintains transmission stability and high-quality audio while giving priority to a short delay time.

MODE3: This audio codec mode adds signal processing that suppresses noise due to unexpected pulse interference.

MODE4: This audio codec mode maintains transmission stability and a low delay while faithfully reproducing the original tone and giving priority to audio quality.

In normal environments, the use of MODE2 (giving priority to short delay time) or MODE4 (giving priority to audio quality) is recommended.

However, select MODE1 when used in combination with a first generation DWX series device, or select MODE3 when used in environments subject to unexpected pulse interference.

Display of the audio signal delay time (SYSTEM DELAY)

The delay between the time the audio signal is input on the digital wireless transmitter and the time it is output on the receiver is displayed.

Because of the time that it takes for a digital wireless microphone to process an audio signal, a delay arises between input on the transmitter and output on the receiver. The indication of this delay time is important when audio signals are also being received from analog devices, which produce no delay.

D: Delay time between input on the transmitter and digital output on the receiver

A: Delay time between input on the transmitter and analog output on the receiver

(When the receiver is inserted in the camcorder slot, the time is not indicated because only the digital interface operates.)

TX (Transmitter Virtual) 1/2 Menu

For details on menu operation, see “Basic menu operations” on page 12.

The Sony digital wireless transmitter sends not only digital audio signals, but also various other information (metadata) related to transmitter settings.

The receiver can display such metadata received from a transmitter using the TX (transmitter virtual) 1/2 menu.

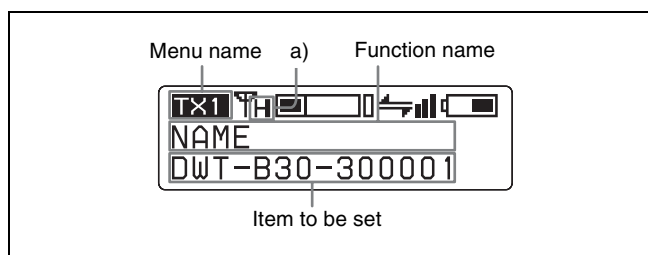
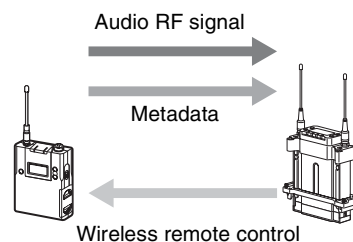

a) Indicates the power setting of the transmitter from which transmission is currently being received.

Note

“NO DATA” appears when the transmitter is turned off or located outside the service area. “NO FUNCTION” appears when the transmitter does not have the metadata transmission function.

Display of the transmitter’s name (NAME)

The name of the transmitter from which transmission is currently being received is displayed.

Displaying of the audio attenuator setting (ATT)

This displays the transmitter audio updaters settings.

Note

“---” appears if LINE is selected in the transmitter INPUT LEVEL.

Display of the low-cut filter setting

(LCF)

The low-cut filter setting of the transmitter is displayed.

Lock function setting display (LOCK)

This disables the transmitter main unit POWER button and locks settings so they cannot be changed. Doing so prevents users from accidentally turning off the power. Settings can be changed via Cross Remote from the receiver even if the transmitter LOCK function is enabled.

Display of the power save setting

(POWER SAVE)

The power save setting of the transmitter is displayed.

Display of audio input level

(INPUT LEVEL)

The audio input level setting of the transmitter from which transmission is currently being received is displayed.

Display of the transmission power setting (RF POWER)

The transmission power setting of the transmitter from which transmission is currently being received is displayed.

Display of the +48V power setting

(+48V)

The +48V power setting of the transmitter is displayed.

Time display (TIME)

The following time is displayed according to the transmitter BATT REMAIN setting.

USAGE TIME: Displays the accumulated transmitter usage time.

BAT.REMAIN: Displays the estimated remaining transmitter operating time.

Display of battery level display settings (BATT REMAIN)

This sets the display method for the transmitter battery level.

Cross Remote (RF REMOTE)

This function must be set to allow the wireless remote control function to be used between the transmitter and receiver.

OFF: Stops the wireless remote control function.

ON: Starts the wireless remote control function with the previously paired receiver.

PAIRING: Executes a new pairing.

For details, see “Using the Cross Remote” on page 18.

Using the Cross Remote

This receiver is equipped with a wireless remote control function that can be used to set the parameters (low-cut filter, attenuation operation, power save mode, etc.) of the transmitter through the TX1/2 menu. This function makes it easier to operate and manage the microphone system while in the field.

This wireless control is 2.4 GHz IEEE802.15.4 compliant and has no effect on the RF band of digital wireless audio. This function is activated when pairing is established between the transmitter and the receiver using the RF REMOTE function.

Note

If the software version is not suitable for use with this receiver, the wireless remote control function may not function. A software update may be necessary to enable proper functioning. For details on software updates, contact your Sony service representative.

For details on transmitter software versions that are compatible with this receiver, see “Transmitter software version” on page 24.

Pairing with a transmitter

The transmitter that you want to control using the wireless remote control function is linked to the receiver via the pairing operation.

In addition to using the following procedure, you can also set the POWER switch on tuner 1 or tuner 2 to ON while holding down the – button to pair the transmitter with the tuner that you turned ON.

- 1 Press the MENU SELECT button repeatedly until the TX1/2 menu is displayed.
- 2 Press the + or – button repeatedly until the RF REMOTE indication is displayed.
- 3 Hold down the SET button until the item to be set flashes.
- 4 Press the + or – button repeatedly to select PAIRING.
- 5 Press the SET button to enter the setting.

Before proceeding to the next step, set the transmitter to be controlled to pairing mode.

For details, refer to the operating instructions supplied with the transmitter.

The receiver starts searching for a transmitter and then displays the transmitter name with which pairing can be executed.

During the search, pressing any operation key on the receiver will cancel pairing mode.

- 6 Press the + or – button repeatedly to select the transmitter to be paired with from among those indicated.
- 7 Press the SET button to enter the setting.

The receiver starts to communicate with the selected transmitter and the wireless remote control condition appears in the display. The condition level (indicated by ) goes up and the remote control function becomes operative.

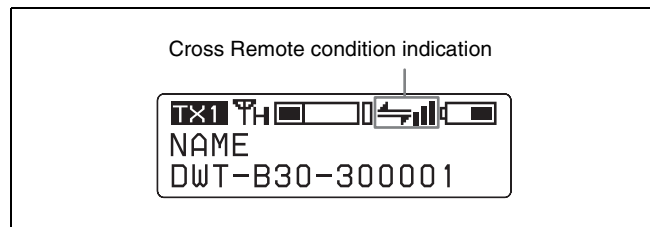





Note

If the receiving channel (CH) configured on the receiver is a channel for which use with the wireless remote control function is restricted on the transmitter side, the UNMATCH screen appears.

In such cases, change the receiving channel on the receiver. If you want to use the restricted channel, set REMOTE to OFF in the transmitter's menu to release the channel restriction, and manually configure the transmitter's channel.

On Cross Remote condition indication

Indicates the signal transmission condition of the wireless remote control function (4 levels).

-  : Good transmission
-  : Somewhat good transmission
-  : Somewhat poor transmission
-  : Poor transmission
-  : Unable to communicate with paired receiver

When the wireless remote control function is off, this indication does not appear.

Using the Cross Remote with a previous pairing

With the TX1/2 menu, select RF REMOTE, and then select ON.

Notes

- When you set RF REMOTE to ON, the transmitter will communicate with the receiver to which it was previously paired. To use the wireless remote control function with another transmitter, you must perform the pairing procedure again for that transmitter.
- Pairing with multiple transmitters is not possible.

The following transmitter settings can be performed through Cross Remote:

- Group/channel/band setting
- Audio attenuator setting
- Low-cut filter setting
- Lock function setting
- Power save setting

- Audio input level setting
- RF transmission power setting
- +48V power setting
- Battery level display setting

For details on the transmitter settings, see “Changing the Settings on the Transmitter” on page 19.

Cancelling the Cross Remote

In the TX1/2 menu, select RF REMOTE, and then OFF.

Notes on the Cross Remote

The wireless remote control function on the receiver uses the 2.4 GHz band and may thus be subject to interference from other devices.

- When pairing fails (“Pairing fail” is displayed), carry out pairing again. Successful communication between the transmitter and the receiver has not occurred within a given amount of time. Pairing may be harder to do when another receiver is engaged in pairing nearby.
- When it becomes hard to use the remote control, the remote control may be improved by switching the wireless remote control function off, then on again in the RF REMOTE display, then re-pairing with the transmitter (change to a channel with less interference).

Changing the Settings on the Transmitter

For details on menu operation, see “Basic menu operations” on page 12.

You can change the settings on the transmitter that is paired with this receiver using the RX1/2 menu or the TX1/2 menu.

The following shows the US model display.

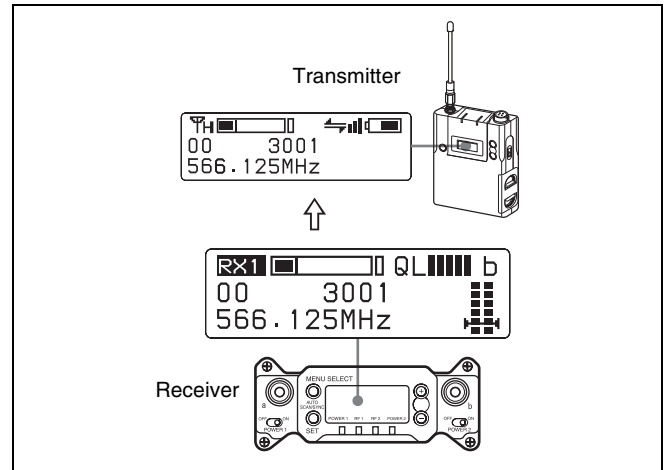

Group/channel setting (GP/CH)

This setting is set through the GP/CH indication of the RX1/2 menu.

For details, see “Selecting the frequency band / group / channel” on page 7.

Audio attenuator setting (ATT)

When the input of the transmitter is set to MIC, the value of the attenuator can be changed.

The attenuator values that can be selected depend on the transmitter function.

Low-cut filter setting (LCF)

The low-cut filter setting of the transmitter can be changed.

Note

The frequency selection depends on the transmitter function.

Lock function setting (LOCK)

This disables the transmitter main unit POWER button and locks settings so they cannot be changed. Doing so prevents users from accidentally turning off the power. Settings can be changed via Cross Remote from the receiver even if the transmitter LOCK function is enabled.

Power-saving setting (POWER SAVE)

To conserve power, this setting allows you to change the transmitter to sleep mode using the wireless remote control function.

Note

When the transmitter changes to sleep mode, transmission of the RF audio signal and metadata is stopped. For this reason, “NO DATA” appears for all items in the TX1/2 menu, except for “SLEEP” in the POWER SAVE indication.

Setting the audio input level (INPUT LEVEL)

You can set the input level to the transmitter.

Transmission power setting (RF POWER)

You can change the transmission power of the transmitter.

Note

Always perform pairing after changing the maximum RF output power setting for a transmitter. If you fail to do so, configuration of RF output power settings via the wireless remote control function may become impossible.

For details on pairing, see “Pairing with a transmitter” on page 18.

+48V power setting (+48V)

Turns the +48V on the transmitter on or off.

Note

This function may not be supported depending on the transmitter.

Battery level display setting (BATT REMAIN)

This sets the display method for the transmitter battery level.

Block Diagram

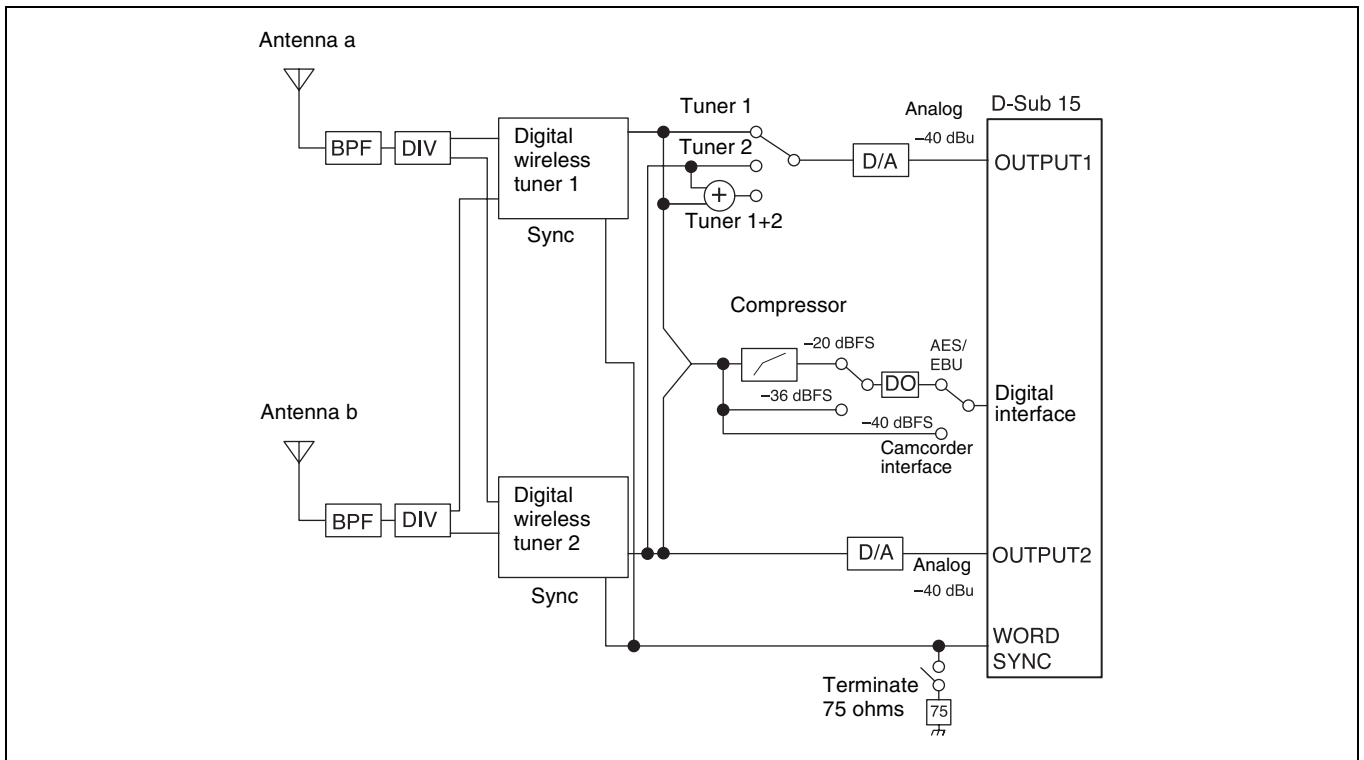

Troubleshooting

If you encounter a problem using this receiver, use the following checklist to find a solution. For any problems with the transmitter or adapter, refer to the operating instructions supplied with the respective device. If the problem persists, consult your Sony dealer.

Symptom	Meanings	Remedy
The receiver does not turn on.	Correctly insert the connected device.	Insert the receiver until it is firmly and completely in, and then secure it with the mounting screws.
There is no sound.	The channel setting on the transmitter is different from that on the receiver.	Use the same channel setting on both the transmitter and receiver.
	The transmitter is turned off.	Check the power supply or battery of the transmitter.
	The setting of the encrypted transmission function on the receiver is different from that on the transmitter.	Confirm that the setting of the encrypted transmission function is the same on both the transmitter and the receiver.
	When the receiver is attached through the optional DWA-01D/F01D wireless adapter, the setting of the sync signal is not appropriate.	Using the sync signal selection (SYNC SOURCE) function, set the sync signal to INTERNAL. When an external sync signal is used, confirm the connection of the sync signal, and set to AUTO or EXTERNAL.
	The audio codec mode settings on the receiver and transmitter do not match.	Configure the same audio codec mode setting for both the receiver and transmitter.
	The Audio Output setting is incorrect when a DWA-SLAU1 is attached.	Set Audio Output so that the receiver output format and the input format of the connected device match.
The sound is weak.	The attenuation level on the transmitter is too high.	Set the attenuator on the transmitter to an appropriate level.
	The AES/EBU reference output level is set to -36 dBFS LINEAR.	Set the reference output level according to the use (see page 13).
There is distortion in the sound.	The attenuation level of the transmitter is zero or too low.	The input level of the transmitter is extremely high. Adjust the attenuation level on the transmitter so that there is no distortion to the sound.
	A LINE level signal is being input while the input level of the transmitter set to MIC.	Refer to the operating instructions supplied with the transmitter and set the input level to LINE.
Encrypted transmission does not function when using a USB connection.	The software version of the transmitter is not suitable for use with this receiver.	Refer to the transmitter software compatibility table, and confirm whether the software version of the transmitter is suitable for use with this receiver (see page 24). If it is not suitable, software update is necessary. Contact your Sony service representative.
There is sound interruption or noise.	The RF indicator lights up even when the transmitter is turned off.	Jamming radio waves are being received. Set the channel whose RF indicator on the receiver does not light up, and then set that same channel on the transmitter. When two or more transmitters are being used, change to another channel group that is unaffected by jamming radio waves. When doing this, the clear channel scan function is useful.
	Two or more transmitters are set to the same channel.	It is not possible to use two or more transmitters that are set to the same channel. Refer to the Sony digital wireless frequency lists and reset the transmitter channel.
	The channel is not set within the same channel group.	The channel plan of the receiver use is set so that no signal interference occurs when two or more transmitters are used simultaneously. Set each transmitter to a different channel within the same channel group.

Symptom	Meanings	Remedy
Wireless remote control is not possible.	Pairing has not been established between the transmitter and receiver.	Carry out pairing (see page 18).
	The receiver is too far from the transmitter for communication to occur.	Check the condition level. If it is low, decrease the distance between the transmitter and the receiver.
	The transmitter that was paired with the receiver has been paired with another receiver.	Carry out pairing again with the transmitter that you want to control.
	The software version of the transmitter is not suitable for use with this receiver.	Refer to the transmitter software compatibility table, and confirm whether the software version of the transmitter is suitable for use with this receiver (see page 24). If it is not suitable, software update is necessary. Contact your Sony service representative.
The display is too dark.	The display brightness is set to low.	Adjust the brightness of the display (see page 14).
“USB CONNECT” appears on the screen and reception and controls are not possible. Or there is no audio output.	The receiver is set to software update standby mode.	Disconnect the USB device from the USB connector. Do not connect any USB devices to the USB connector other than when updating the software.

Important Notes on Operation

Notes on using the receiver

- The use of some frequency bands may be restricted by law, depending on the country or region. Check in advance before use.
- The digital wireless microphone system product must be used within a temperature range of 0 °C to 50 °C (32 °F to 122 °F).
- Operating the receiver near electrical equipment (motors, transformers, or dimmers) may cause it to be affected by electromagnetic induction. Keep the receiver as far from such equipment as possible.
- The presence of the lighting equipment may produce electrical interference over the entire frequency range. Position the receiver so that interference is minimized.
- To avoid degradation of the signal-to-noise ratio, do not use the receiver in noisy places or in locations subject to vibration, such as the following:
 - near electrical equipment, such as motors, transformers or dimmers
 - near air conditioning equipment or places subject to direct air flow from an air conditioner
 - near public address loudspeakers
 - where adjacent equipment might knock against the tunerKeep the receiver as far from such equipment as possible or use buffering material.

On cleaning

- If the receiver is used in a very humid or dusty place or in a place subject to an active gas, clean its surface as well as the connectors with a dry, soft cloth soon after use. Lengthy use of the receiver in such places or not cleaning it after its use in such places may shorten its life.
- Clean the surface and the connectors of the receiver with a dry, soft cloth. Never use thinner, benzene, alcohol or any other chemicals, since these may mar the finish.

Transmitter software version

If the software version is not suitable for use with this receiver, the wireless remote control and encrypted transmission functions may not function. Refer to the following tables for transmitter software versions that are compatible with this receiver. A software update may be necessary to enable proper functioning. For details on software updates, contact your Sony service representative.

For details on confirming the software version, refer to the operating instructions for each transmitter.

Transmitter Model No.: U3040, U4250

Model name	Software version
DWM-01	Ver 1.12 or later
DWT-B01/DWT-P01 (Serial No. 10999 or below)	Ver 1.22 or later
DWT-B01 (Serial No. 11001 or above)	Ver 2.13 or later
DWT-P01 (Serial No. 11001 or above)	Ver 2.12 or later

Transmitter Model No.: Other

Model name	Software version
DWM-01	Ver 1.12 or later
DWT-B01	Ver 2.13 or later
DWT-P01	Ver 2.12 or later

Audio degradation due to weak reception

In a digital wireless system, sound quality is maintained up to the maximum transmission range. Beyond this point, as the radio wave becomes weaker, data synchronization is lost and the connection finally breaks. Sony digital wireless systems suppress the occurrence of large noise between these two points as the signal weakens. As a result, digital processing is conducted in a way that allows the signal to degrade in a very natural way.

To prevent electromagnetic interference from portable communication devices

The use of portable telephones and other communication devices near the DWR-S03D may result in malfunction and interference with audio signals. It is recommended that portable communication devices near the DWR-S03D be turned off.

Specifications

Tuner section

Type of Receiver	Slot-in (2 channels)
Transmission Method	WiDIF-HP (×2)
Type of reception	True diversity
Circuit system	Double superheterodyne
Local oscillators	Crystal-controlled PLL synthesizer
RF input terminal	SMA-R, 50 ohms
Antenna Type	Detachable
Sensitivity	20 dBμ or less (at ambient temperature 25 °C (77 °F), bit error rate = 1×10^{-5} , no decline in S/N ratio)

Audio section

Audio output connector	D-sub 15-pin connector (male) (when DWA-SLAS1 is attached) D-sub 25-pin connector (male) (when DWA-SLAU1 is attached)
Reference output level	Analog: -40 dBu Digital: -36 dBFS/-20 dBFS (switchable)
Dynamic range	106 dB or more (A-weighted)
T.H.D	MODE1, MODE2, MODE4: 0.03% or less MODE3: 0.3% or less
Audio delay	Analog output: MODE1: 2.1 ms MODE2: 1.7 ms MODE3: 3.0 ms MODE4: 1.7 ms AES/EBU output: MODE1: 1.9 ms MODE2: 1.5 ms MODE3: 2.8 ms MODE4: 1.5 ms When connected to a Sony camcorder (digital connection) MODE1: 1.9 ms MODE2: 1.3 ms MODE3: 2.7 ms MODE4: 1.4 ms

General

Operating voltage	6 V to 18 V DC
Consumption current	3.5 W or less (when DWA-SLAS1 is attached) 4.0 W or less (when DWA-SLAU1 is attached)

Operating temperature

0 °C to 50 °C (32 °F to 122 °F)

Storage temperature

-20 °C to +60 °C (-4 °F to +140 °F)

Wireless remote control

2.4-GHz IEEE802.15.4 compliant

Dimensions (Unit: mm (inches))

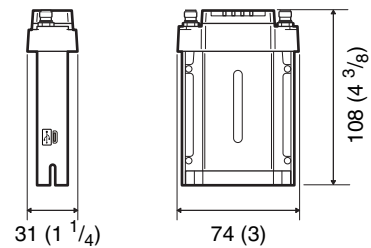

(the supplied antennas are attached)

When DWA-SLAS1 is attached

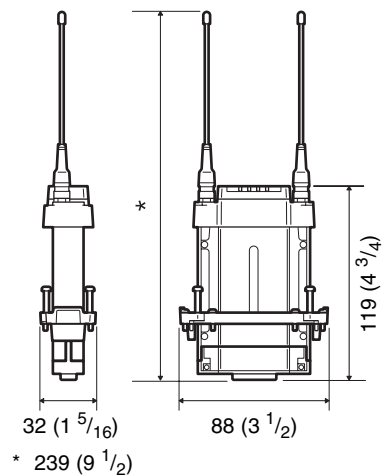

When DWA-SLAU1 is attached

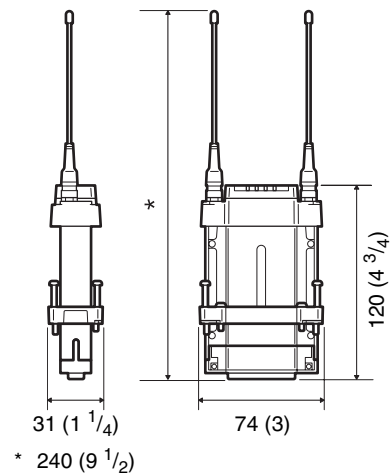

Mass

Approx. 125 g (4.4 oz) (Receiver only, not including accessories or the supplied antenna)

Approx. 180 g (6.3 oz) (including the DWA-SLAS1 and the supplied antennas)

Approx. 185 g (6.5 oz) (including the DWA-SLAS1 and the supplied antennas)

- Supplied accessories Antenna (2)
Before Using This Unit (4)
- Optional Accessories DWA-SLAS1 digital wireless adapter (slot-in adapter)
DWA-SLAU1 digital wireless adapter (slot-in adapter)
DWA-01D wireless adapter
DWA-F01D wireless adapter

Design and specifications are subject to change without notice.

Carrier Frequencies and Channel Steps

Underlined items are the factory setting.

US models

Channel step: 25 kHz

Model No.	Frequency band block	Frequency band	Frequency	Group/channel (factory setting)
UC (TV14-TV36, TV38)	<u>TV14-25</u>	TV14-17	470.125 - 493.875 MHz	<u>00 1801 494.125 MHz</u>
		<u>TV18-21</u>	494.125 - 517.875 MHz	
		TV22-25	518.125 - 541.875 MHz	
	TV26-38	TV26-29	542.125 - 565.875 MHz	
		TV30-33	566.125 - 589.875 MHz	
		TV34-36	590.125 - 607.875 MHz	
		TV37	Not available	
		TV38	614.125 - 615.875 MHz	

The maximum transmission power (MAX RF POWER) for TV38 (614.125 - 615.875 MHz) is 10 mW.

European models

Channel step: 25 kHz

Model No.	Frequency band block	Frequency band	Frequency	Group/channel (factory setting)
L (TV21-TV38)	<u>TV21-29</u>	<u>TV21-23</u>	470.025 - 494.000 MHz	<u>00 2101 470.125 MHz</u>
		TV24-26	494.025 - 518.000 MHz	
		TV27-29	518.025 - 542.000 MHz	
	TV30-38	TV30-32	542.025 - 566.000 MHz	
		TV33-35	566.025 - 590.000 MHz	
		TV36-37	590.025 - 606.000 MHz	
		TV38	606.025 - 614.000 MHz	
H (TV33-TV51)	<u>TV33-41</u>	<u>TV33-35</u>	566.025 - 590.000 MHz	<u>00 3301 566.125 MHz</u>
		TV36-37	590.025 - 606.000 MHz	
		TV38	606.025 - 614.000 MHz	
		TV38-40	606.025 - 630.000 MHz	
		TV41	630.025 - 638.000 MHz	
	TV42-51	TV42-44	638.025 - 662.000 MHz	
		TV45-47	662.025 - 686.000 MHz	
		TV48-50	686.025 - 710.000 MHz	
		TV51	710.025 - 714.000 MHz	

