

F8n Pro

MultiTrack Field Recorder

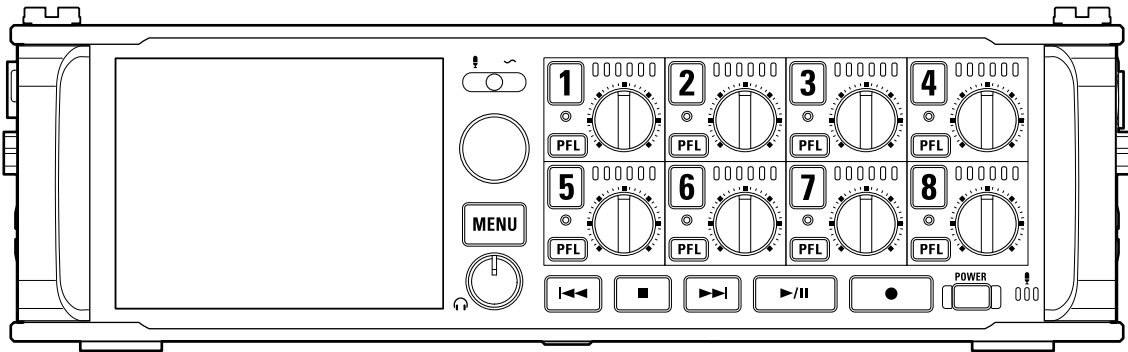

Operation Manual

You must read the Usage and Safety Precautions before use.

©2022 ZOOM CORPORATION

Copying or reprinting this manual in part or in whole without permission is prohibited.

Product names, registered trademarks and company names in this document are the property of their respective companies. All trademarks and registered trademarks in this document are for identification purposes only and are not intended to infringe on the copyrights of their respective owners.

Proper display is not possible on grayscale devices.

Notes about this Operation Manual

You might need this manual in the future. Always keep it in a place where you can access it easily. The contents of this document and the specifications of the product could be changed without notice.

- Windows® is a trademark or registered trademark of Microsoft® Corporation.
- Mac, macOS, iPadOS and iOS are registered trademarks of Apple Inc. in the USA and other countries.
- iOS is a trademark or registered trademark of Cisco Systems, Inc. in the USA and other countries, and it is used under license.
- Google Play is a trademark of Google LLC.
- The SD, SDHC and SDXC logos are trademarks.
- Other trademarks and trade names are the property of their respective companies.
- Recording from copyrighted sources, including CDs, records, tapes, live performances, video works and broadcasts, without permission of the copyright holder for any purpose other than personal use is prohibited by law. ZOOM CORPORATION will not assume any responsibility related to infringements of copyrights.

Contents

| | |
|--|-----|
| Notes about this Operation Manual..... | 2 |
| F8n Pro overview..... | 6 |
| Achieving high audio quality throughout recording and editing..... | 6 |
| Functions of parts..... | 10 |
| Overview of screens shown..... | 15 |
| Recording process..... | 28 |
| Making preparations..... | 29 |
| Loading SD cards..... | 29 |
| Supplying power..... | 30 |
| Connecting input equipment..... | 33 |
| Turning the power on/off..... | 40 |
| Setting the date and time (first time starting up)..... | 41 |
| Making input settings..... | 43 |
| Input and output signal flow..... | 43 |
| Adjusting the input signal monitoring balance..... | 44 |
| Setting the track knob function (Track Knob Option)..... | 45 |
| Adjusting the L/R track volume..... | 49 |
| Monitoring the input signals of specific tracks (PFL/SOLO)..... | 50 |
| Setting the input source (Input Source)..... | 51 |
| Setting the monitoring sound on the PFL Screen (PFL Mode)..... | 53 |
| Cutting low-frequency noise (HPF)..... | 55 |
| Using the input limiter (Input Limiter)..... | 57 |
| Inverting the input phase (Phase Invert)..... | 66 |
| Changing the phantom power settings (Phantom)..... | 68 |
| Changing the plugin power setting (Plugin Power)..... | 74 |
| Delaying input signals (Input Delay)..... | 75 |
| Converting mid-side input to ordinary stereo (Stereo Link Mode)..... | 77 |
| Adjusting the input levels of multiple tracks simultaneously (Trim Link)..... | 80 |
| Adjusting the side level of a mid-side mic capsule (Side Mic Level)..... | 82 |
| Changing the automatic mixing setting (Auto Mix)..... | 83 |
| Setting the format of Ambisonic Mode..... | 85 |
| Setting the mic position used for ambisonic recording (Mic Position)..... | 90 |
| Making output setting..... | 93 |
| Setting signals sent to headphones (Headphone Routing)..... | 93 |
| Outputting alerts through headphones (Alert Tone Level)..... | 96 |
| Setting the headphone output Volume Curve..... | 98 |
| Boosting headphone output to alleviate interference from recorded sound (Digital Boost)..... | 100 |
| Disabling outputs (Output On/Off)..... | 102 |
| Setting the standard output level (Output Level)..... | 104 |
| Setting output levels..... | 106 |

| | |
|--|------------|
| Delaying output signals (Output Delay)..... | 108 |
| Using the output limiter (Output Limiter)..... | 110 |
| Selecting signals sent to the main outputs (MAIN OUT Routing)..... | 115 |
| Selecting signals sent to the sub outputs (SUB OUT Routing)..... | 117 |
| Recording..... | 119 |
| Enabling recording on SD cards and setting file formats..... | 119 |
| Selecting inputs and adjusting levels..... | 121 |
| Setting the sampling rate (Sample Rate)..... | 123 |
| Setting WAV file bit depth (WAV Bit Depth)..... | 125 |
| Setting MP3 file bit rate (MP3 Bit Rate)..... | 127 |
| Capturing audio before recording starts (Pre Rec)..... | 128 |
| Maximum file size (File Max Size)..... | 130 |
| Showing total recording times for long recordings (Time Counter)..... | 132 |
| Moving the previously recorded take to the FALSE TAKE folder..... | 134 |
| Using timecode..... | 135 |
| Setting the recording take..... | 162 |
| Using the slate mic and slate tone..... | 177 |
| Recording..... | 194 |
| Playing recordings..... | 195 |
| Playing recordings..... | 195 |
| Mixing takes..... | 196 |
| Monitoring the playback signals of specific tracks during playback..... | 198 |
| Changing the playback mode (Play Mode)..... | 199 |
| Managing files..... | 201 |
| Folder and file structure..... | 201 |
| Take and folder operations (FINDER)..... | 204 |
| Overview of take information (metadata) stored in files..... | 215 |
| Checking and editing take metadata..... | 216 |
| Writing sound reports (Create Sound Report)..... | 227 |
| Using USB functions..... | 231 |
| Exchanging data with a computer (SD Card Reader)..... | 231 |
| Using as an audio interface..... | 233 |
| Using the FRC-8..... | 244 |
| Using the FRC-8 as a controller (Connect)..... | 244 |
| Setting the type of keyboard connected to the FRC-8 (Keyboard Type)..... | 246 |
| Setting FRC-8 fader and knob operation (Knob/Fader Mode)..... | 248 |
| Setting user keys for the FRC-8 (User Key)..... | 250 |
| Setting the power supply used by the FRC-8 (Power Source)..... | 252 |
| Powering the FRC-8 with USB bus power (USB Bus Power)..... | 254 |
| Setting the FRC-8 LED brightness (LED Brightness)..... | 256 |
| Updating the FRC-8 firmware..... | 258 |
| Controlling the F8n Pro from a smartphone/tablet..... | 261 |
| Making various settings..... | 262 |
| Setting how timecode is shown (Home Timecode Display Size)..... | 262 |

| | |
|---|------------|
| Setting level meter appearance (Level Meter)..... | 264 |
| Setting the LED brightness (LED Brightness)..... | 270 |
| Making display settings (LCD)..... | 271 |
| Adding marks when recording/playing (PLAY Key Option)..... | 274 |
| Setting the keys held (Key Hold Target)..... | 276 |
| Setting the date and time (Date/Time (RTC))..... | 278 |
| Disabling the Automatic Power Saving function (Auto Power Off)..... | 281 |
| Setting the power supply used (Power Source)..... | 283 |
| Backing up and loading F8n Pro settings (Backup/Load Settings)..... | 286 |
| Restoring factory default settings..... | 290 |
| Managing SD cards..... | 291 |
| Checking SD card information (Information)..... | 291 |
| Testing SD card performance (Performance Test)..... | 292 |
| Formatting SD cards (Format)..... | 296 |
| Managing the firmware..... | 298 |
| Checking the firmware versions..... | 298 |
| Updating the firmware..... | 299 |
| About the F8n Pro Shortcut function..... | 300 |
| Checking the F8n Pro Shortcut function (Shortcut List)..... | 300 |
| List of shortcuts..... | 301 |
| Appendix..... | 303 |
| Troubleshooting..... | 303 |
| Detailed product diagrams..... | 305 |
| Metadata list..... | 307 |
| Specifications..... | 312 |

F8n Pro overview

Achieving high audio quality throughout recording and editing

With dual AD converter circuits and support for 32-bit float WAV files, the F8n Pro can maintain the highest audio quality from recording to post-production.

Recording

Dual AD converter circuits enable recording the loudest to the quietest sounds without adjusting gain.



Post-production

Recording with 32-bit float WAV file formats allows the same audio quality to be retained when editing.



Dual AD converter circuit overview

For each input circuit, the F8n Pro has two AD converters with different input gains. This design enables high-quality audio recording without the need to adjust gain settings, a step that is normally indispensable.

Providing amazing dynamic range

By combining two AD converters, a wide dynamic range not possible with a single AD converter has been realized.

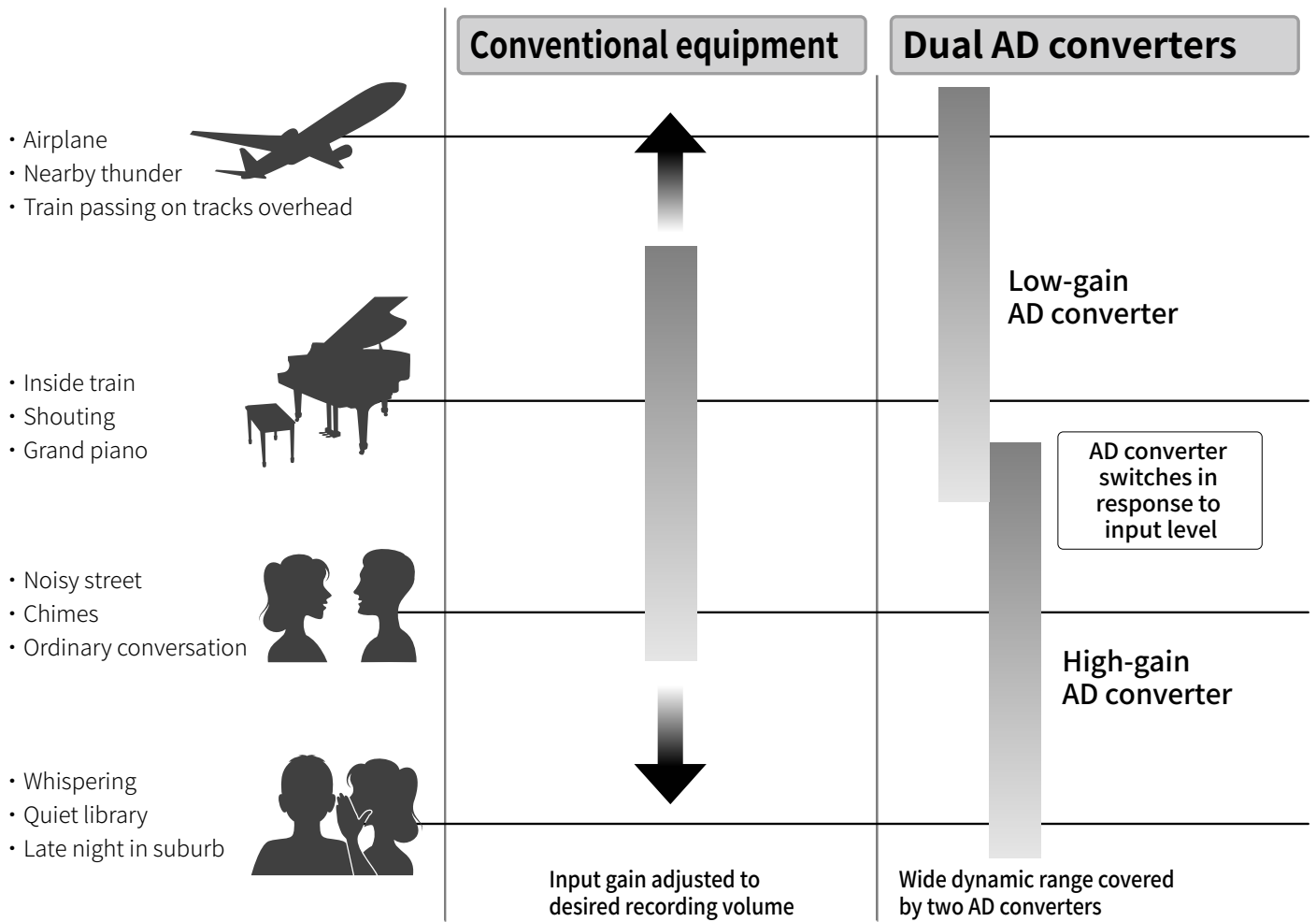

Switching between two AD converters

The F8n Pro constantly monitors data from the two AD converters, and automatically selects the one that provides the best recording results.

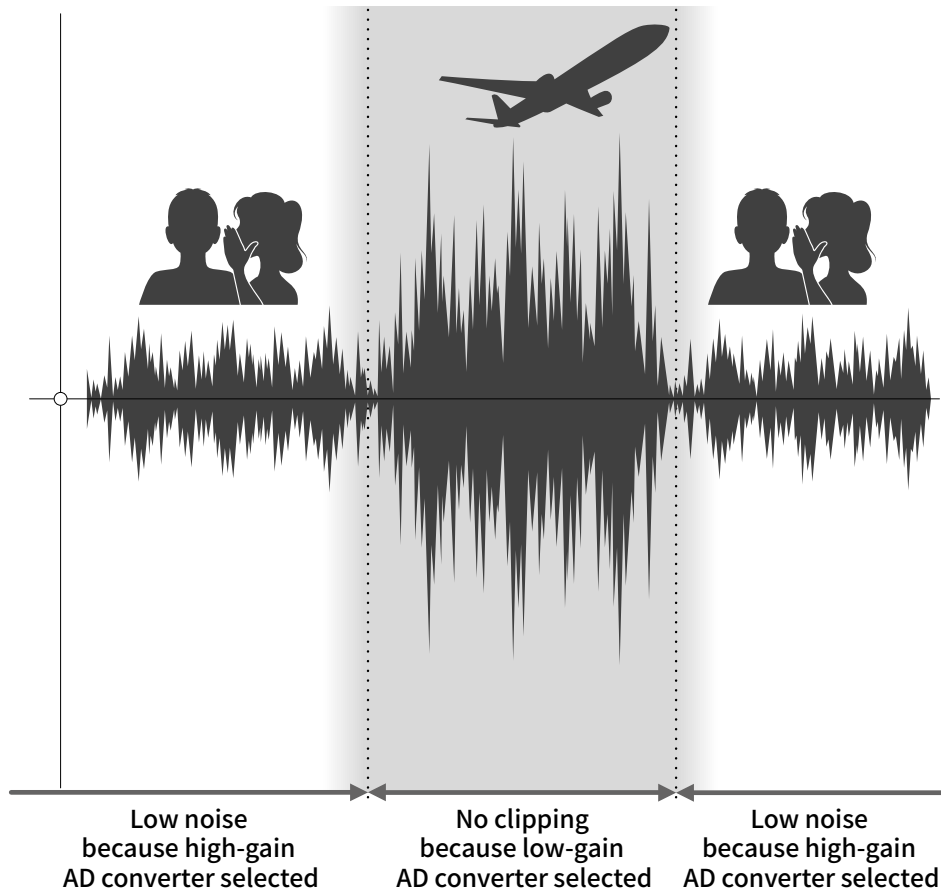

32-bit float WAV file overview

32-bit float WAV files have the following advantages over conventional 16/24-bit linear WAV files. These features enable the quality of the sound during recording to be maintained even during post-production.

Resolution advantage

32-bit float WAV files have the advantage of being able to maintain high resolution even at low volumes. As a result, quiet sounds can be made louder when editing after recording without degrading their quality.

■ 16/24-bit linear WAV

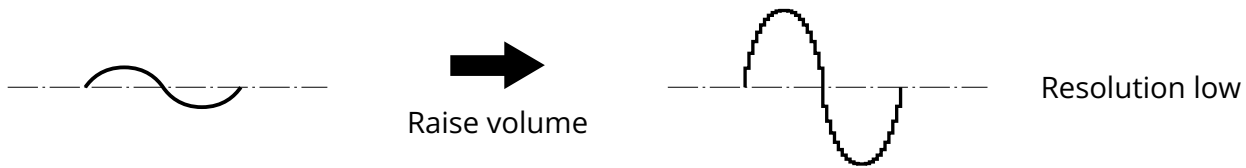

■ 32-bit float WAV

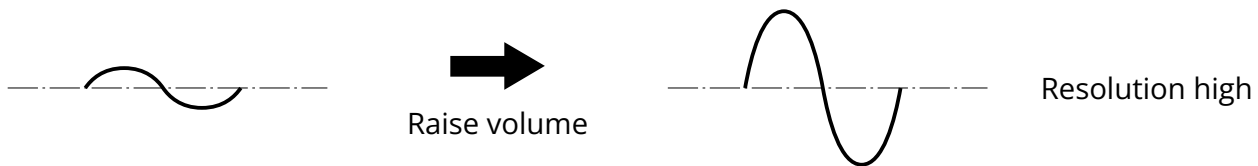

Clipping advantage

If a waveform sounds clipped when output from the F8n Pro or in a DAW, it can be edited after recording to lower its volume and restore an unclipped waveform because the data in the 32-bit float WAV file itself is not clipped.

■ 16/24-bit linear WAV

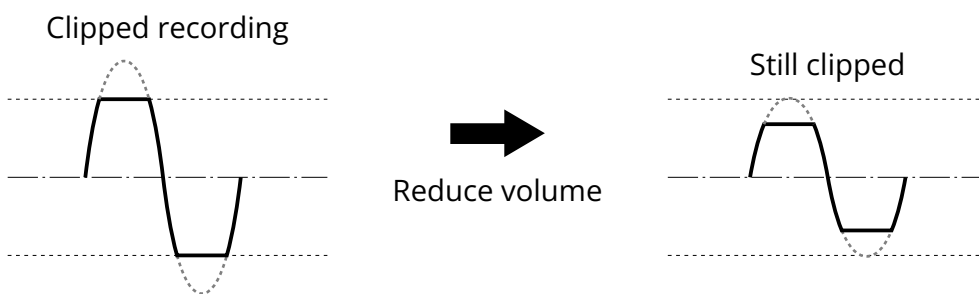

■ 32-bit float WAV

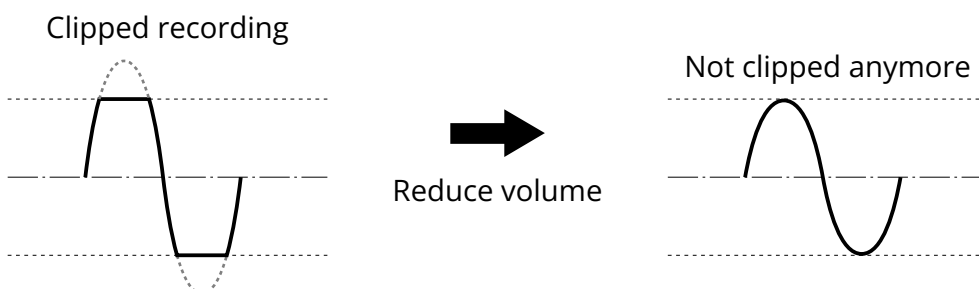

Functions of parts

Front

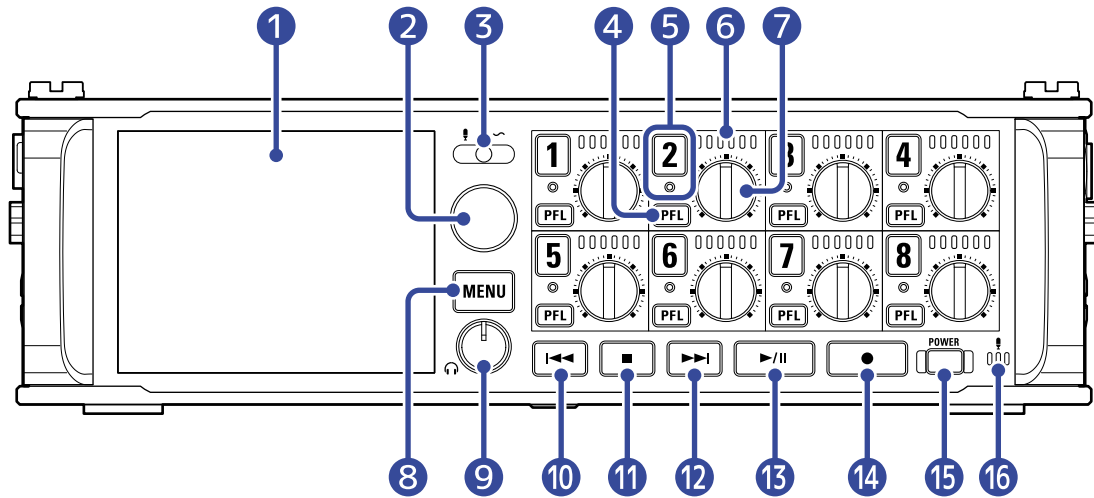

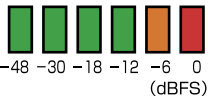
- 1 Display (LCD)**
This shows the recorder status and Menu Screen. (→ [Overview of screens shown](#))
- 2 Selection encoder**
Use this to select and to confirm in various menus.
- 3 Slate switch**
Use this to record slate tones and with the slate mic.
- 4 PFL button**
Press this to open the PFL Screen. The status indicator of the selected track will light orange. (→ [PFL Screen](#))
- 5 Track button/status indicator**
Press the track button, lighting the status indicator red, to enable that track for recording.
- 6 LED level meter**
This lights according to the track input level.

| | | | | | |
|--------|-----|-----|-----|----|---|
| █ | █ | █ | █ | █ | █ |
| -48 | -30 | -18 | -12 | -6 | 0 |
| (dBFS) | | | | | |
- 7 Track knob**
This controls the track fader.
Depending on the setting, this can also adjust trim or pan.
- 8 MENU button**
Press this to open the Menu Screen or return to the previous screen.
- 9 Headphone volume knob**
This adjusts the headphone volume.

- 10 REW button
Use this to search backward and to skip to the previous track.
- 11 STOP button
This stops recording and playback.
- 12 FF button
Use this to search forward and to skip to the next track.
- 13 PLAY/PAUSE button
This starts and pauses track playback.
- 14 REC button
This starts recording.
- 15 Power button
This turns the power on/off.
- 16 Slate mic
Use this for slate mic recording.

Back

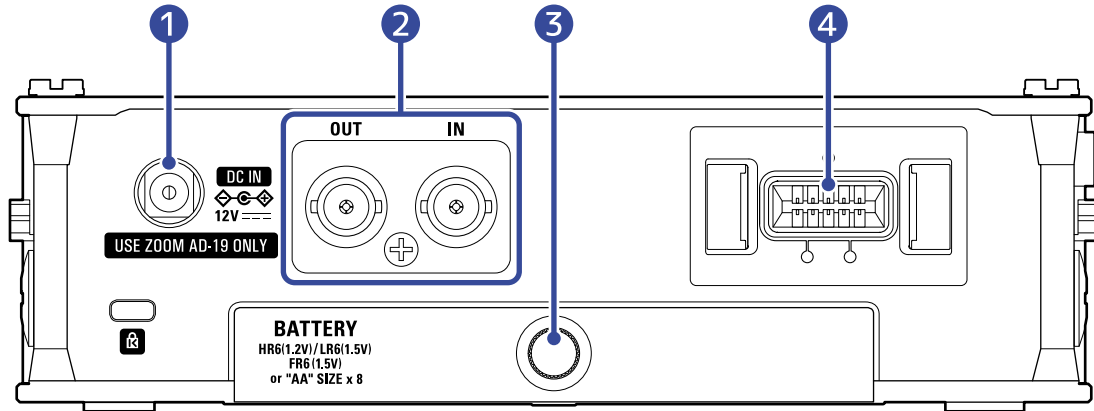

- 1 12 V DC IN connector**
Connect the dedicated AC adapter (ZOOM AD-19) here.
- 2 TIMECODE IN/OUT connectors**
Use cables with BNC connectors to input and output timecode.
- 3 Battery cover**
Open this when installing or removing AA batteries.
- 4 MIC IN connector**
Mic capsules (sold separately) can be attached. (→ [Connecting mic capsules](#))

Left side

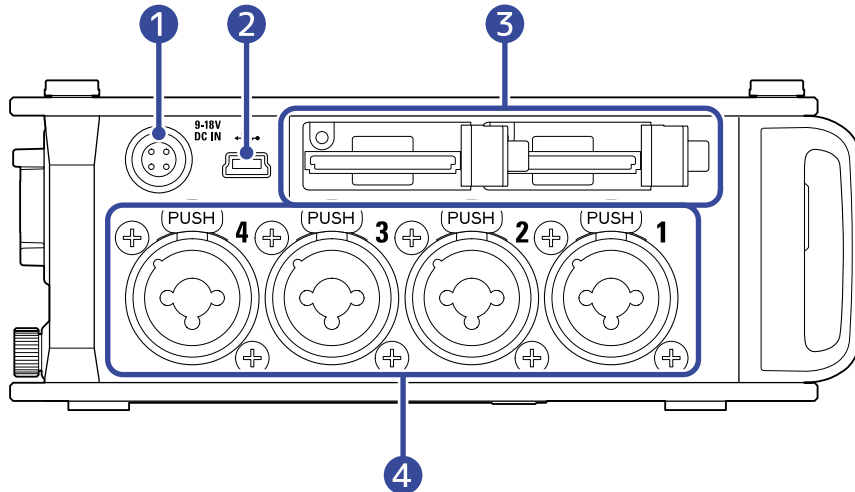

1 EXT DC IN connector

External DC power supplies that support Hirose 4-pin connectors can be connected here.



2 USB (Mini-B) port

Connect this to a computer, smartphone or tablet to use the F8n Pro as an SD card reader or audio interface.

3 SD card slots

Up to 2 SD cards can be loaded.

4 Inputs 1-4

Connect mics and instruments to these. These can be used with XLR and TRS connectors. When disconnecting the XLR plug, pull it while pressing Lock release button ("PUSH" area).

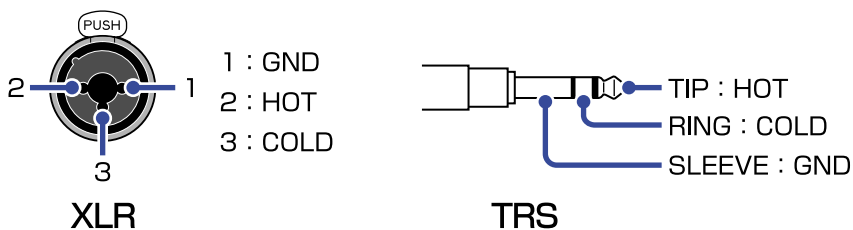

Right side

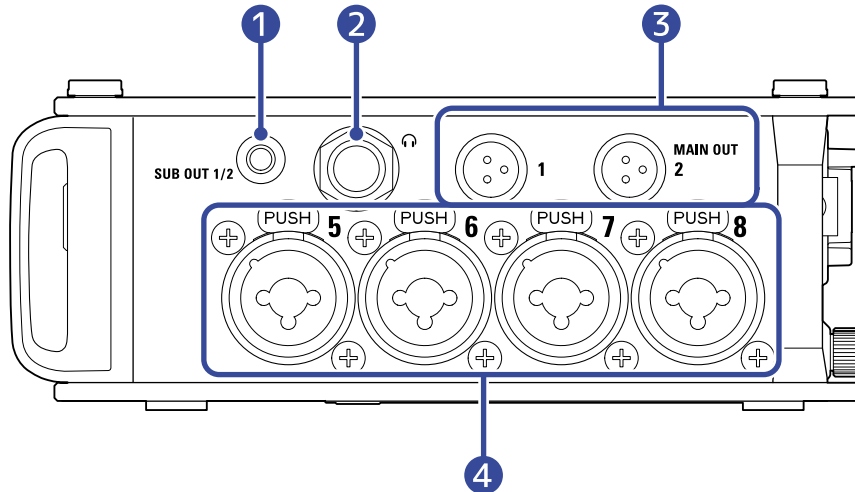

1 SUB OUT jack

This stereo mini jack (unbalanced) can be used to output sound.

2 Headphone jack

This can output sound to headphones.

3 MAIN OUT jacks

Use cables with TA3 connectors to output sound to speakers.

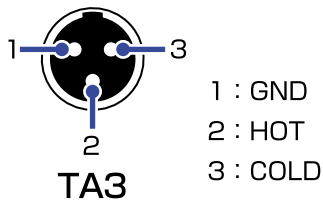

4 Inputs 5-8

Connect mics and instruments to these. These can be used with XLR and TRS connectors. When disconnecting the XLR plug, pull it while pressing Lock release button ("PUSH" area).

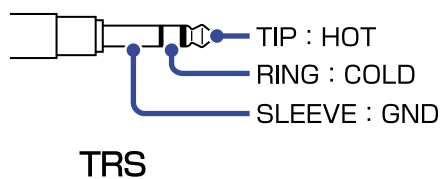
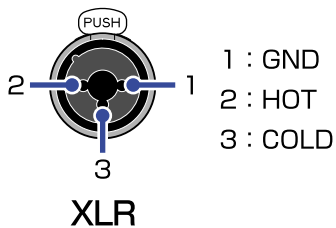

Overview of screens shown

This section explains the screens shown on the F8n Pro display.

Screen list

■ [Home Screen](#)

This appears on the display when the F8n Pro power is turned on.

Use  to switch the screens. On screens with selectable items, move past the first/last item to switch screens.

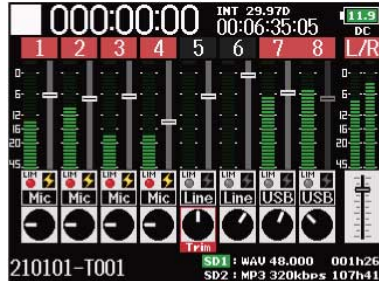

[Mixer Screen](#)

Check input settings and adjust input levels.

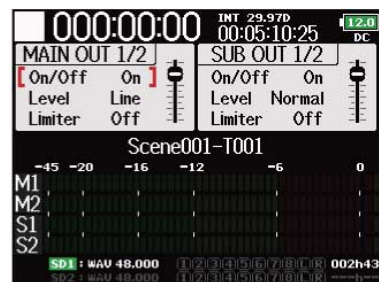

[MAIN/SUB OUT Setting Screen](#)

Check/change output settings and adjust output levels.



[Level Meters Screen](#)

Check levels precisely with horizontal level meters.

■ [PFL Screen](#)

Open the PFL Screen by pressing .

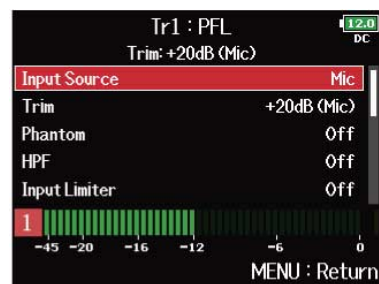

Change the input settings of specific tracks while monitoring their input signals.

■ [Menu Screen](#)

Open the Menu Screen by pressing .

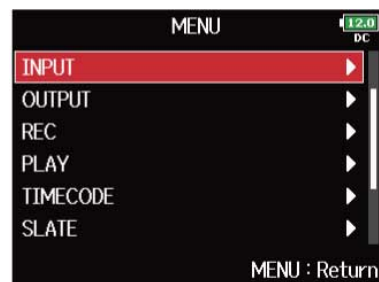

Various settings can be changed. When the Menu Screen is open, open the Home Screen by pressing and holding .

Home Screen



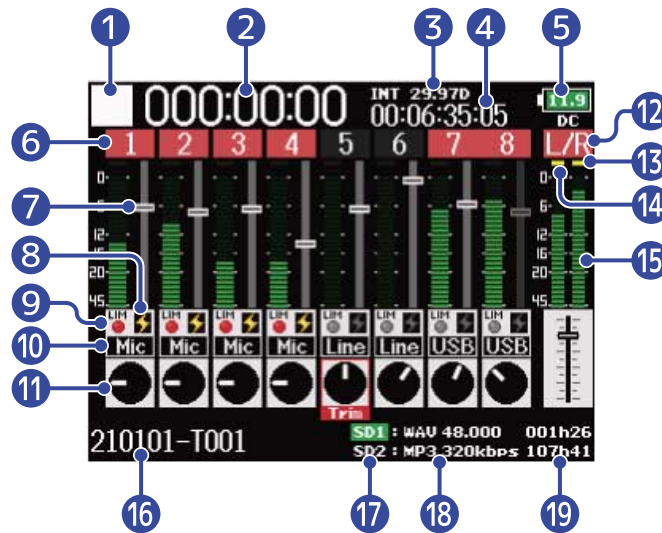

Mixer Screen

You can easily check the elapsed playing/recording time, input/output levels, trim settings, input sources and other settings.



1 Status icon

This icon shows the recording status.

-  : Stopped
-  : Recording
-  : Paused (when recording)
-  : Playing
-  : Paused (when playing)

2 Counter

This shows the elapsed recording time (when recording) or playback time (when playing).

3 Frame rate

- INT: internal timecode enabled
- EXT: external input timecode enabled

4 Timecode

This shows the recording/playback timecode.

5 Power type and remaining power

When the remaining battery charge becomes low, change the batteries (→ [Installing batteries](#)), connect an AC adapter (→ [Connecting an AC adapter](#)) or connect an external DC power supply (→ [Using an external DC power supply](#)).



Power type

- DC: AC adapter
- EXT: external DC power supply
- AA: batteries

6 Track number

This shows the track number and status.

- Red: input enabled
- Green: playback track enabled
- Grey: input disabled

Stereo-linked inputs are displayed as  .

7 Fader

This shows the fader position.

8 Phantom power status

- Lit: enabled
- Unlit: disabled

9 Limiter status

- Grey: disabled
- Red: enabled
- Yellow: functioning

10 Input source

This shows the selected input source. (→ [Setting the input source \(Input Source\)](#))

11 Trim

Use  shows the trim adjustment for each track.

Press  to adjust the trim of the selected track.

12 L/R tracks

13 Limiter indicators

These light yellow when the limiter functions.

14 Clipping indicators

These retain the peak levels of input/playback signals for a set amount of time after fader adjustment.

15 Level meters

These show the track and L/R levels.

16 Recording/playback take name

Press and hold  when stopped to show the name of the next track to be recorded.

17 Playback card

- Green: used for playback
- Grey: no card

18 Recording/playback file format and sampling rate

This is shown by card.

19 Remaining time

The remaining recordable time (when recording) or remaining playback time (when playing) is shown by card.

■ MAIN/SUB OUT Setting Screen

This shows the MAIN OUT and SUB OUT settings. They can be turned on/off, and their standard levels, limiters, and fader levels can be set.

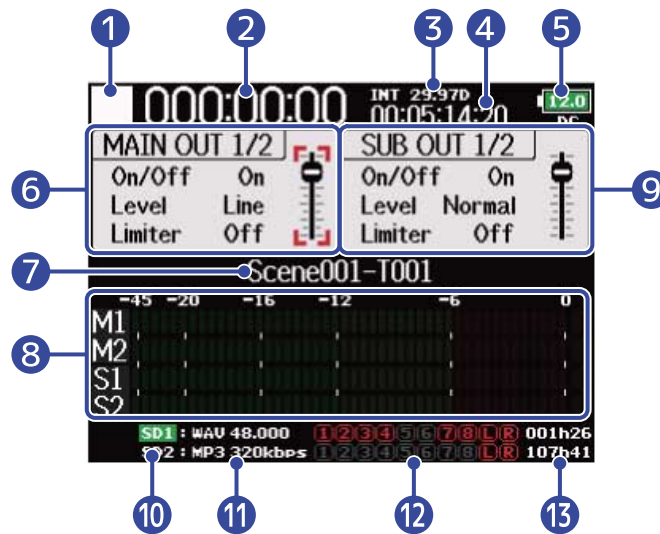

1 Status icon

This icon shows the recording status.

- : Stopped
- : Recording
- : Paused (when recording)
- : Playing
- : Paused (when playing)

2 Counter

This shows the elapsed recording time (when recording) or playback time (when playing).

3 Frame rate

- INT: internal timecode enabled
- EXT: external input timecode enabled

4 Timecode

This shows the recording/playback timecode.

5 Power type and remaining power

When the remaining battery charge becomes low, change the batteries (→ [Installing batteries](#)), connect an AC adapter (→ [Connecting an AC adapter](#)) or connect an external DC power supply. (→ [Using an external DC power supply](#))



Full ←————→ Empty

Power type

- DC: AC adapter

- EXT: external DC power supply
- AA: batteries

6 MAIN OUT 1/2 setting area

The following items can be set.

- On/Off: Enables/disables the output. (→ [Disabling outputs \(Output On/Off\)](#))
- Level: Adjusts the standard output level. (→ [Setting the standard output level \(Output Level\)](#))
- Limiter: Enables/disables the output limiter. (→ [Using the output limiter \(Output Limiter\)](#))
- Fader: Adjusts the output level.

7 Recording/playback take name

Press and hold  when stopped to show the name of the next track to be recorded.

8 Level meters

These show the output levels of the MAIN OUT and SUB OUT.

9 SUB OUT 1/2 setting area

The following items can be set.

- On/Off: Enables/disables the output. (→ [Disabling outputs \(Output On/Off\)](#))
- Level: Adjusts the standard output level. (→ [Setting the standard output level \(Output Level\)](#))
- Limiter: Enables/disables the output limiter. (→ [Using the output limiter \(Output Limiter\)](#))
- Fader: Adjusts the output level.

10 Playback card

- Green: used for playback
- Grey: no card

11 Recording/playback file format and sampling rate

This is shown by card.

12 Recording/playback tracks

Red: Recording tracks

Green: Playback tracks

Gray: Tracks that are not recorded/played

13 Remaining time

The remaining recordable time (when recording) or remaining playback time (when playing) is shown by card.

■ Level Meters Screen



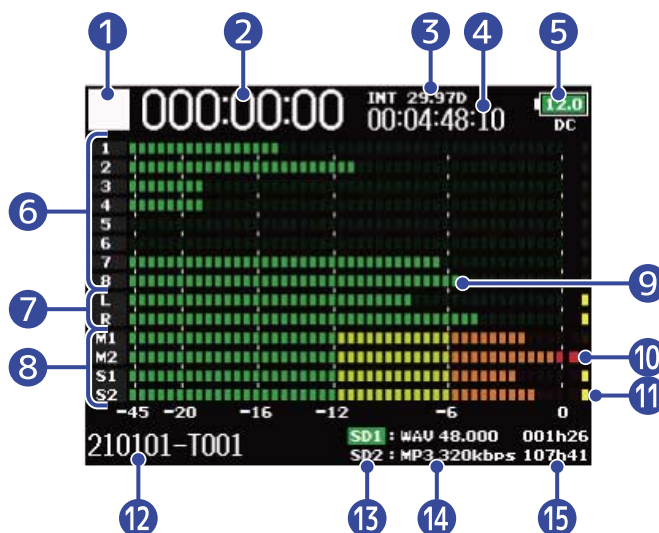

This shows large level meters for each track, allowing levels to be checked more precisely.

The level meters shown can be switched by using  to change to the sources set for View 1-4. (→ [Setting level meter appearance \(Level Meter\)](#))



1 Status icon

This icon shows the recording status.

-  : Stopped
-  : Recording
-  : Paused (when recording)
-  : Playing
-  : Paused (when playing)

2 Counter

This shows the elapsed recording time (when recording) or playback time (when playing).

3 Frame rate

- INT: internal timecode enabled
- EXT: external input timecode enabled

4 Timecode

This shows the recording/playback timecode.

5 Power type and remaining power

When the remaining battery charge becomes low, change the batteries (→ [Installing batteries](#)), connect an AC adapter (→ [Connecting an AC adapter](#)) or connect an external DC power supply. (→ [Using an external DC power supply](#))



Power type

- DC: AC adapter
- EXT: external DC power supply
- AA: batteries

6 Levels for tracks 1–8

These show the input/playback levels for tracks 1–8.

7 Levels for L/R tracks

These show the input/playback levels for the L/R tracks.

8 Levels for MAIN OUT 1/2 and SUB OUT 1/2 tracks

These show the output levels for the MAIN OUT 1/2 and SUB OUT 1/2 tracks.

9 Level meters

These show the track and L/R levels.

10 Clipping indicators

These retain the peak levels of input/playback signals for a set amount of time after fader adjustment.

11 Limiter indicators

These light yellow when the limiter is functioning.

12 Recording/playback take name

Press and hold  when stopped to show the name of the next track to be recorded.

13 Playback card

- Green: used for playback
- Grey: no card

14 Recording/playback file format and sampling rate

This is shown by card.

15 Remaining time

The remaining recordable time (when recording) or remaining playback time (when playing) is shown by card.

PFL Screen

You can make the input settings of the selected track including input source and input level.

Press **[PFL]** of the track that you want to set or monitor to open its PFL Screen. Press **[PFL]** again to return to the previous screen.

You can monitor only the input signal of the selected track while the PFL Screen is open.

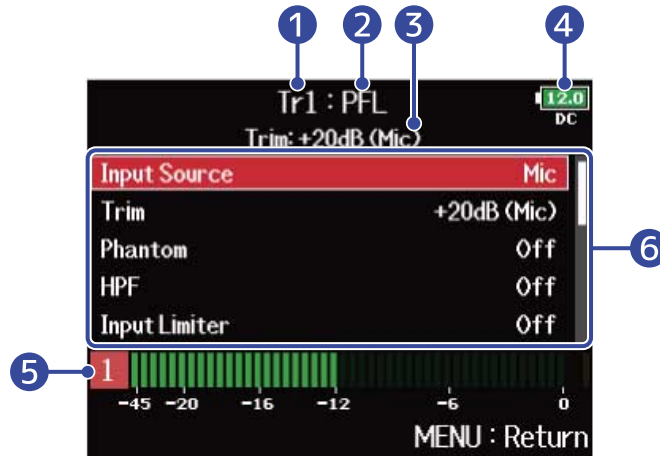

1 Track name

This shows the selected track.

2 PFL mode

This shows the monitor mode (prefader (PFL) or postfader (SOLO)). (→ [Setting the monitoring sound on the PFL Screen \(PFL Mode\)](#))

3 Trim adjustment value/input source

4 Power type and remaining power

When the remaining battery charge becomes low, change the batteries (→ [Installing batteries](#)), connect an AC adapter (→ [Connecting an AC adapter](#)) or connect an external DC power supply. (→ [Using an external DC power supply](#))



Full ←————→ Empty



Power type

- DC: AC adapter
- EXT: external DC power supply
- AA: batteries

5 Level meter

This shows the prefader (PFL) or postfader (SOLO) input signal level.

6 Input setting items

Use  to select a setting item, and press . This opens a screen where that input setting can be changed. For details about each setting, see the links.

| Setting items | Explanation |
|------------------|--|
| Input Source | Set the input source. (→ Setting the input source (Input Source)) |
| Trim | Set the input level. (→ Adjusting input levels) |
| Phantom | Make phantom power settings. (→ Changing the phantom power settings (Phantom)) |
| HPF | Set the high pass filter. (→ Cutting low-frequency noise (HPF)) |
| Input Limiter | Set the limiter. (→ Using the input limiter (Input Limiter)) |
| Fader | Set the fader. |
| Pan | Set the panning. |
| Phase Invert | Set the phase of the input signal. (→ Inverting the input phase (Phase Invert)) |
| Side Mic Level | Set the side mic level of a mid-side mic capsule. (→ Adjusting the side level of a mid-side mic capsule (Side Mic Level)) |
| Input Delay | Set the input delay. (→ Delaying input signals (Input Delay)) |
| Plugin Power | Set the plugin power. (→ Changing the plugin power setting (Plugin Power)) |
| Stereo Link | Set stereo linking. (→ Linking inputs as a stereo pair) |
| Stereo Link Mode | Set the stereo link mode. (→ Converting mid-side input to ordinary stereo (Stereo Link Mode)) |
| PFL Mode | Set the monitoring sound when the PFL Screen is open. (→ Setting the monitoring sound on the PFL Screen (PFL Mode)) |

Menu Screen

From this screen, various F8n Pro settings, including input/output, recording/playback, timecode, system and SD card settings can be made. Files can also be managed.

The Menu Screen is opened by pressing .

You can open the Home Screen while the Menu Screen is open by pressing and holding .



1 Title

The title of the selected screen is shown.

2 Power type and remaining power

When the remaining battery charge becomes low, change the batteries (→ [Installing batteries](#)), connect an AC adapter (→ [Connecting an AC adapter](#)) or connect an external DC power supply. (→ [Using an external DC power supply](#))



Full ← → Empty

Power type

- DC: AC adapter
- EXT: external DC power supply
- AA: batteries

3 Setting items

Use  to select a setting item and press  to open a screen where the setting can be changed.

Character input screen

A character input screen appears on the display when inputting characters, including file names. Use the select encoder to input characters.

1. Use  to select the desired character or function and press  to confirm.



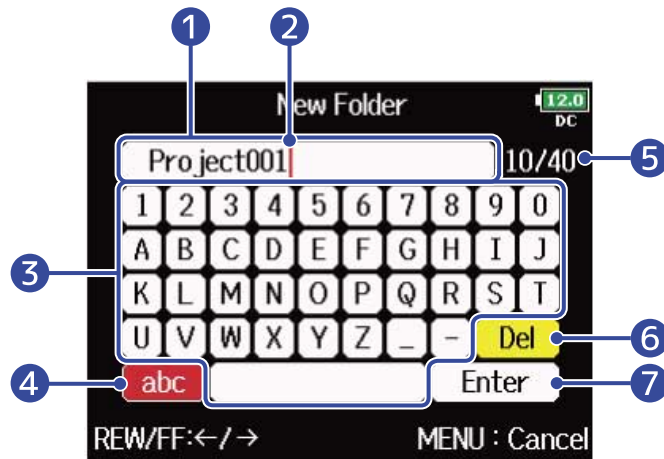

The selected character or function is highlighted in red.





- 1 Character input area**
This shows the input characters.
- 2 Character input position**
The character will be input at this position.
- 3 Character selection area**
Select characters to input here.
- 4 Change character type**
This changes the characters that can be selected in the character selection area (capital letters/ numbers → small letters/numbers → symbols/automatic input).
The following characters can be input automatically by selecting automatic input keys.
 - (Date): Automatically inputs the date. Example: 210210 (year, month, day)
 - (Time): Automatically inputs the time. Example: 130950
 - (Project): Automatically inputs "Project***"
 - (Scene): Automatically inputs the scene name
- 5 Number of characters input/Maximum number of characters**
- 6 Delete character**
- 7 Confirm character**

■ Other operations

- Press  / : Moves cursor in box.

- Press  +  : Deletes the previous character.
- Press  +  : Moves the cursor to “Enter”.
- Press  : Cancels editing and returns to the previous screen.

2. Repeat step 1 to input characters. When you have finished inputting characters, use  to select “Enter” and press .

NOTE:

The characters and symbols that can be used are as follows.

! # \$ ' () + , - ; = @ [] ^ _ ` { } ~ (space) A-Z, a-z, 0-9

Recording process

Recording with the F8n Pro follows the process shown below.

The data created for each recording occurrence is called a "take".

Connect

- Connect mics, instruments, audiovisual equipment and other devices to Inputs 1–8. (→ [Connecting mics/other devices to Inputs 1–8](#))
 - Connect a mic capsule to the MIC IN connector. (→ [Connecting mic capsules](#))
-





Turn power on

- Turn the F8n Pro power on. (→ [Turning the power on](#))
-



Prepare before recording

1. Set the SD card and file format for recording. (→ [Enabling recording on SD cards and setting file formats](#))
Set the recording file format for each SD card separately.
 2. Select the recording tracks. (→ [Selecting inputs](#))
Use track keys to select. The indicators for selected tracks light red and you will be able to monitor input sounds.
Press two track keys simultaneously to link them as a stereo track. (→ [Linking inputs as a stereo pair](#))
 3. Make recording settings.
Make other settings, including for the following functions: Pre recording (→ [Capturing audio before recording starts \(Pre Rec\)](#)), High pass filter (→ [Cutting low-frequency noise \(HPF\)](#)), limiter (→ [Using the input limiter \(Input Limiter\)](#))
 4. Adjust the input levels. (→ [Adjusting input levels](#))
The side mic level can also be adjusted when using a mid-side mic capsule.
-

Record

- Press  to start and  to stop recording. (→ [Recording](#))
You can add marks during recording.
 - Press  to start recording a new track.
 - Press  to pause.
-

Play back and check

- Press  to start playback and  or  to stop it. (→ [Playing recordings](#))
You can add marks during playback.
-

Check take information

- Check and edit metadata. (→ [Checking and editing take metadata](#))
-

Making preparations

Loading SD cards

1. When the power is off, open the SD card slot cover, and insert an SD card all the way into the slot.

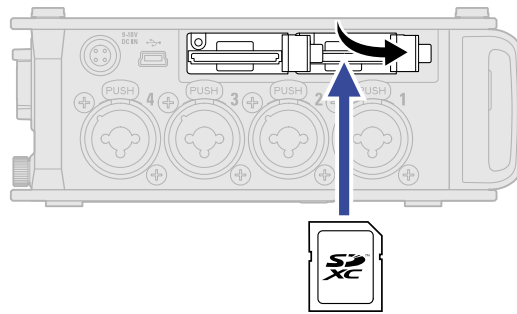

To remove an SD card, push it further into the slot and then pull it out.

2. Close the SD slot cover.

NOTE:

- Always make certain that the power is off when inserting or removing an SD card. Inserting or removing a card while the power is on could result in data loss.
- When inserting an SD card, be sure to insert the correct end with the top side up.
- Recording and playback are not possible when an SD card is not loaded in the F8n Pro.
- After purchasing a new SD card, always format it using the F8n Pro to maximize performance. (→ [Formatting SD cards \(Format\)](#))

Supplying power

The F8n Pro can operate using either an AC adapter, external DC power supply or batteries. The power supplies will be used in the following order of priority. AC adapter > external DC power supply > batteries.

Installing batteries

To run the F8n Pro using batteries, install 8 AA batteries in the battery compartment.

1. Turn the power off and then loosen the screw in the battery cover to open it.

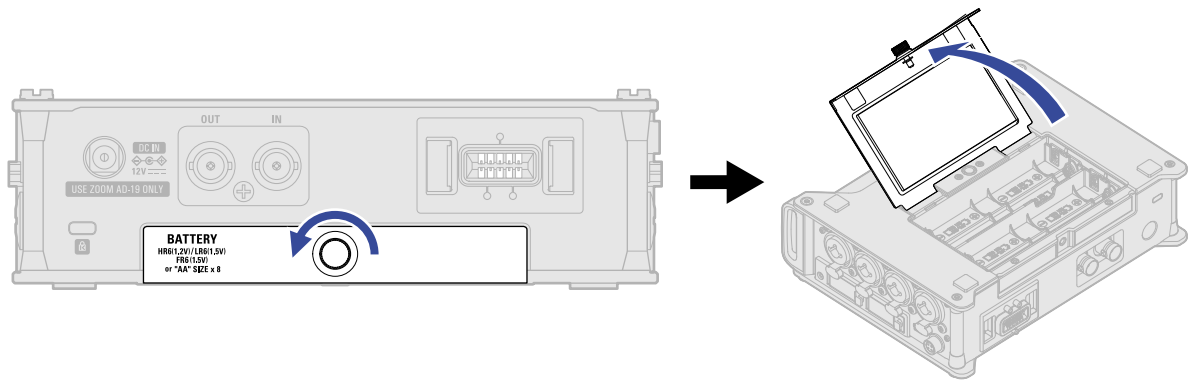

2. Install the batteries.

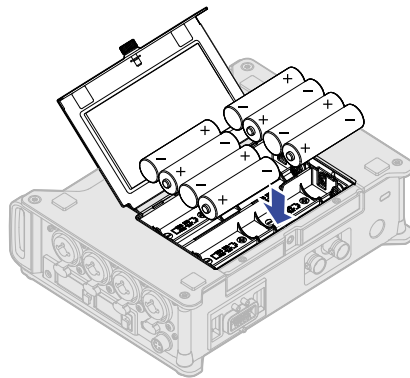

3. Close the battery cover and tighten the screw.

NOTE:

- Be careful because the battery case could become loose unexpectedly if the cover screw is not tightened firmly.
- Use only one type of battery (alkaline, NiMH or lithium) at a time.
- Set the type of battery used correctly so that the amount of remaining battery charge can be shown accurately. (→ [Setting the power supply used \(Power Source\)](#))
- If the battery charge becomes low, turn the power off immediately and install new batteries. You can check the remaining battery charge on the Home Screen. (→ [Home Screen](#))

Connecting an AC adapter

Connect the cable of the dedicated AC adapter (AD-19) to the 12 V DC IN connector, and connect the AC adapter to an outlet.

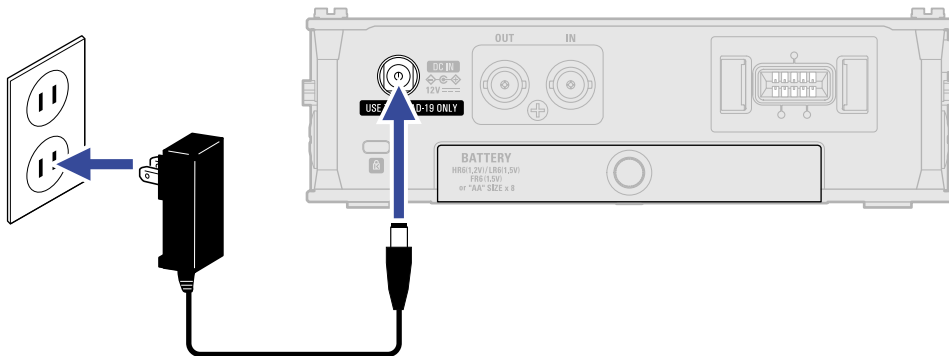

Using an external DC power supply

1. Connect the external DC power supply equipment to the EXT DC IN connector. Connect a 9–18V direct-current power supply.

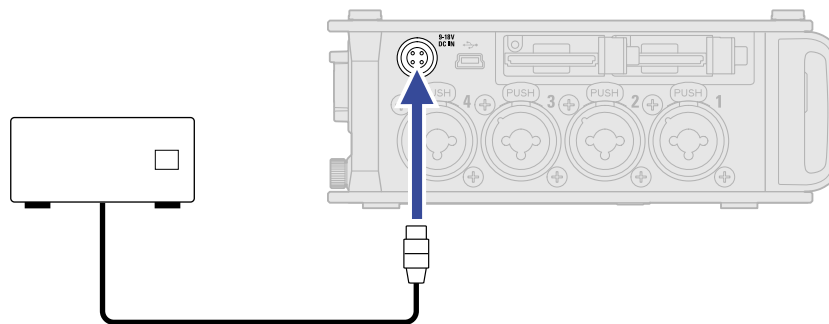

2. If there is an adapter, plug the adapter into an outlet.

NOTE:

When connecting an external DC power supply, be sure to make the power supply settings. (→ [Setting the power supply used \(Power Source\)](#))

Connecting input equipment

Connecting mics/other devices to Inputs 1–8

The F8n Pro can record a total of 10 tracks simultaneously: 8 individual tracks with signals coming from Inputs 1–8 and a stereo mix of these inputs on left and right tracks.

You can connect mics and the outputs of line-level devices such as keyboards, mixers, or instruments with active electronics to Inputs 1–8 and record them to tracks 1–8. Alternatively, Inputs 1 and 2 can instead receive input from a ZOOM mic capsule connected to the F8n Pro MIC IN connector.

■ Connecting mics

Connect dynamic and condenser mics with XLR plugs to Inputs 1–8.

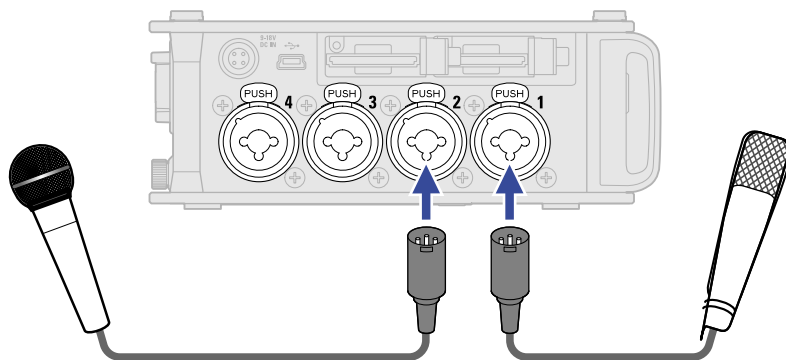

- When connecting mics, set the input source to “Mic”. (→ [Setting the input source \(Input Source\)](#))
- Phantom power (+24V/+48V) can be supplied to condenser mics. (→ [Changing the phantom power settings \(Phantom\)](#))
- When disconnecting a mic, gently pull on the XLR plug while simultaneously pushing the connector lock release button.

■ Connecting line level equipment

Connect TRS plugs from keyboards and mixers directly to Inputs 1–8.

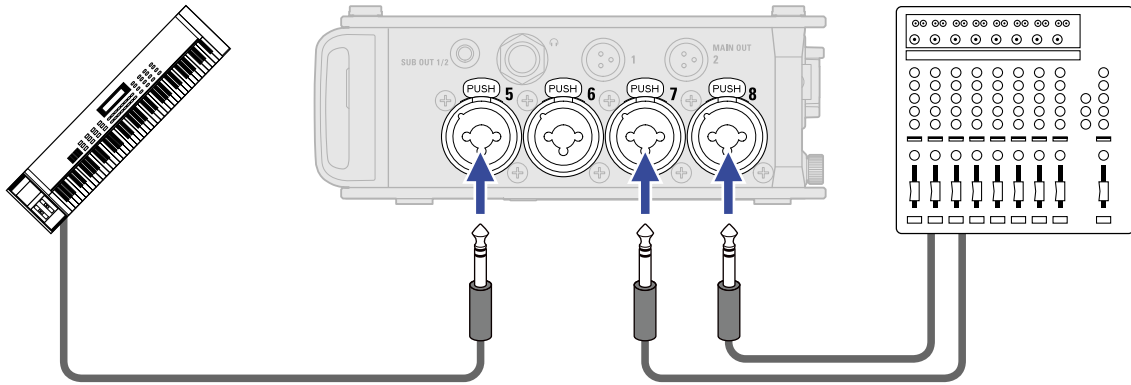

- When connecting keyboards and mixers, set the input source to “Line”. (→ [Setting the input source \(Input Source\)](#))
- Direct input of passive guitars and basses is not supported. Connect these instruments through a mixer or effects device.

Connecting mic capsules

A ZOOM mic capsule can be connected to the MIC IN connector on the back of the F8n Pro.

NOTE:

- The mic capsule input is assigned to tracks 1/2.
- When a mic capsule is connected, Inputs 1/2 cannot be used.

1. Remove the protective caps from the F8n Pro and the mic capsule or extension cable.

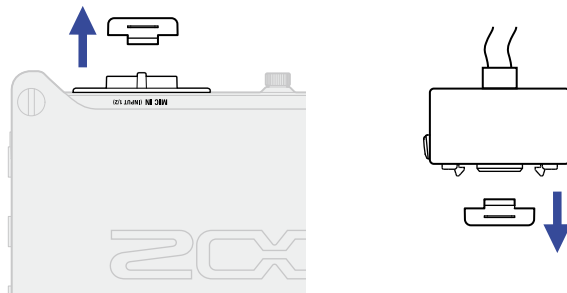

2. While pressing the side buttons on the mic capsule or extension cable, connect it to the main unit, inserting it completely.

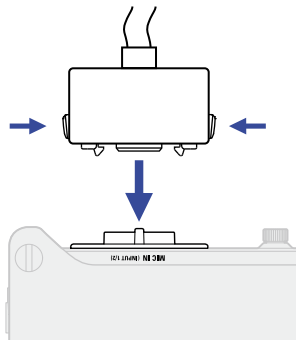

3. To disconnect the mic capsule or extension cable, pull it away from the main unit while simultaneously pressing the buttons on its sides.

NOTE:

- Do not use too much force when disconnecting. Doing so could damage the mic capsule, extension cable or main unit.
- Reattach the protective cap when a mic capsule is not connected.

■ Mic capsule compatibility

| Mic capsule | Description | F8n Pro compatible |
|---|---|--------------------|
|  | XAH-8 XY-AB mic capsule | No |
|  | VRH-8 Ambisonics VR mic capsule | No |
|  | EXH-8 External XLR input capsule | No |
|  | XYH-6 Adjustable X/Y stereo microphone capsule (→ Changing the plugin power setting (Plugin Power)) | Yes |
|  | XYH-5 Shock mounted X/Y stereo microphone capsule (→ Changing the plugin power setting (Plugin Power)) | Yes |
|  | MSH-6 Mid-Side stereo microphone capsule (→ Adjusting the side level of a mid-side mic capsule (Side Mic Level)) | Yes |
|  | SSH-6 Mid-Side stereo shotgun microphone capsule (→ Adjusting the side level of a mid-side mic capsule (Side Mic Level)) | Yes |
|  | SGH-6 Shotgun microphone capsule | Yes |
|  | EXH-6 Dual XLR/TRS input capsule (→ Linking inputs as a stereo pair) | Yes |

Stereo input

By enabling the stereo link for tracks 1/2, 3/4, 5/6 or 7/8, the corresponding Inputs (1/2, 3/4, 5/6 or 7/8) can be handled as a stereo pair. (→ [Linking inputs as a stereo pair](#))

When linked, Input 1, 3, 5 or 7 becomes the left channel and Input 2, 4, 6 or 8 becomes the right channel.

Connection example

Recording is possible in the following kinds of situations.

■ While filming

- Input 1: gun mic for main subject sound (XLR connection)
- Inputs 2-5: wireless lavalier mics for performers (TRS connections)
- Inputs 6-7: mics for ambient sound (XLR connections)

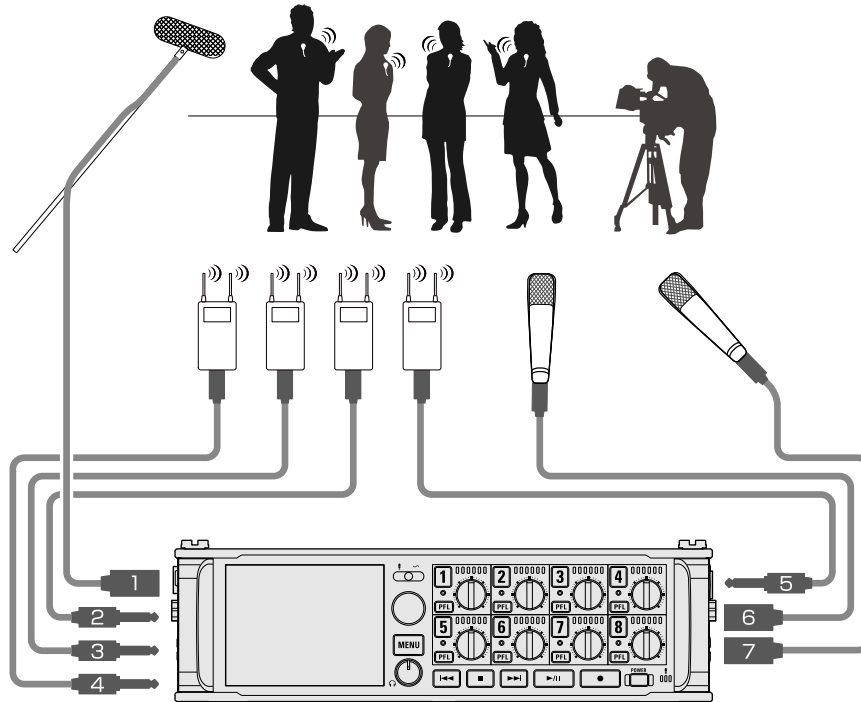

■ Concert recording

- Inputs 1-4: mics for stage performance (XLR connections)
- Inputs 5-6: line-level PA mixer outputs (TRS connections)
- Inputs 7-8: mics for audience sound (XLR connections)

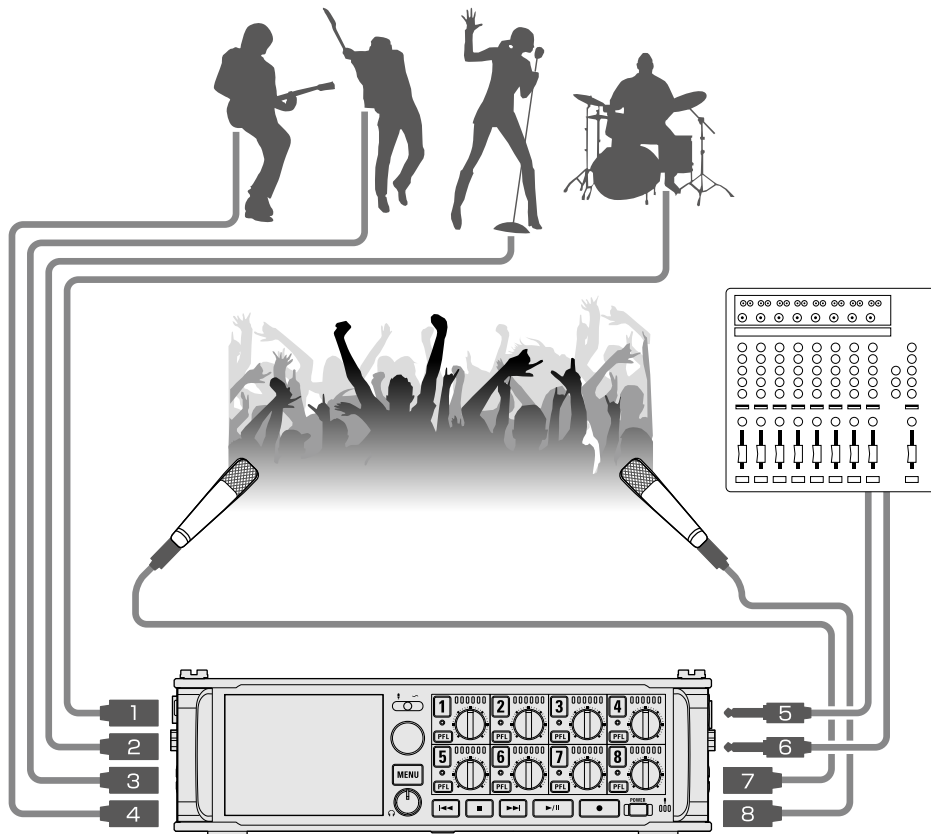

Turning the power on/off

Turning the power on

1. Press and hold  briefly.

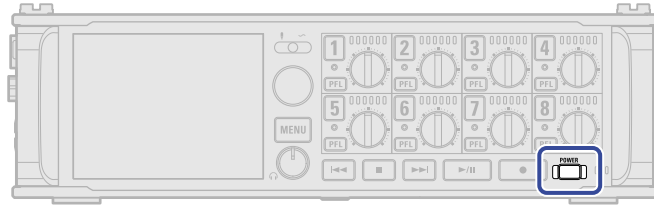

This turns the F8n Pro power on and  lights.

The first time the power is turned on after purchase, as well as after the F8n Pro has been restored to its factory default settings, screens to set the date and time will appear. Make these settings. (→ [Setting the date and time \(first time starting up\)](#))

NOTE:

- The power will automatically turn off if it is unused for 10 hours. To keep the power on at all times, disable the automatic power saving function. (→ [Disabling the Automatic Power Saving function \(Auto Power Off\)](#))
- If "No Card!" appears on the display, confirm that an SD card is inserted properly.
- If "Card Protected!" appears on the display, the SD card write-protection is enabled. Slide the lock switch on the SD card to disable write-protection.
- If "Invalid Card!" appears on the display, the card is not formatted correctly. Format the card or use a different card. (→ [Formatting SD cards \(Format\)](#), [Loading SD cards](#))

■ Turning the power off

1. Press and hold  briefly.



Keep pressing it until the ZOOM logo appears on the display.

NOTE:



When the power is turned off, the current mixer settings are saved on the F8n Pro.

Setting the date and time (first time starting up)

The first time the power is turned on after purchase, set the date and time when the Set Date/Time Screen opens. The date and time are added to recording files.

1. Use  to select a setting item and press .



2. Use  to change the value and press .



3. Repeat steps 1-2 to set the date and time.

4. When finished setting, use  to select "Enter" and press .



NOTE:

If power is not supplied by an AC adapter for a long time, date and time settings will be reset. If the date and time setting screen appears during startup, set them again.

HINT:

The date and time setting can also be changed later from the Menu Screen. (→ [Setting the date and time \(Date/Time \(RTC\)\)](#))

Making input settings

Input and output signal flow

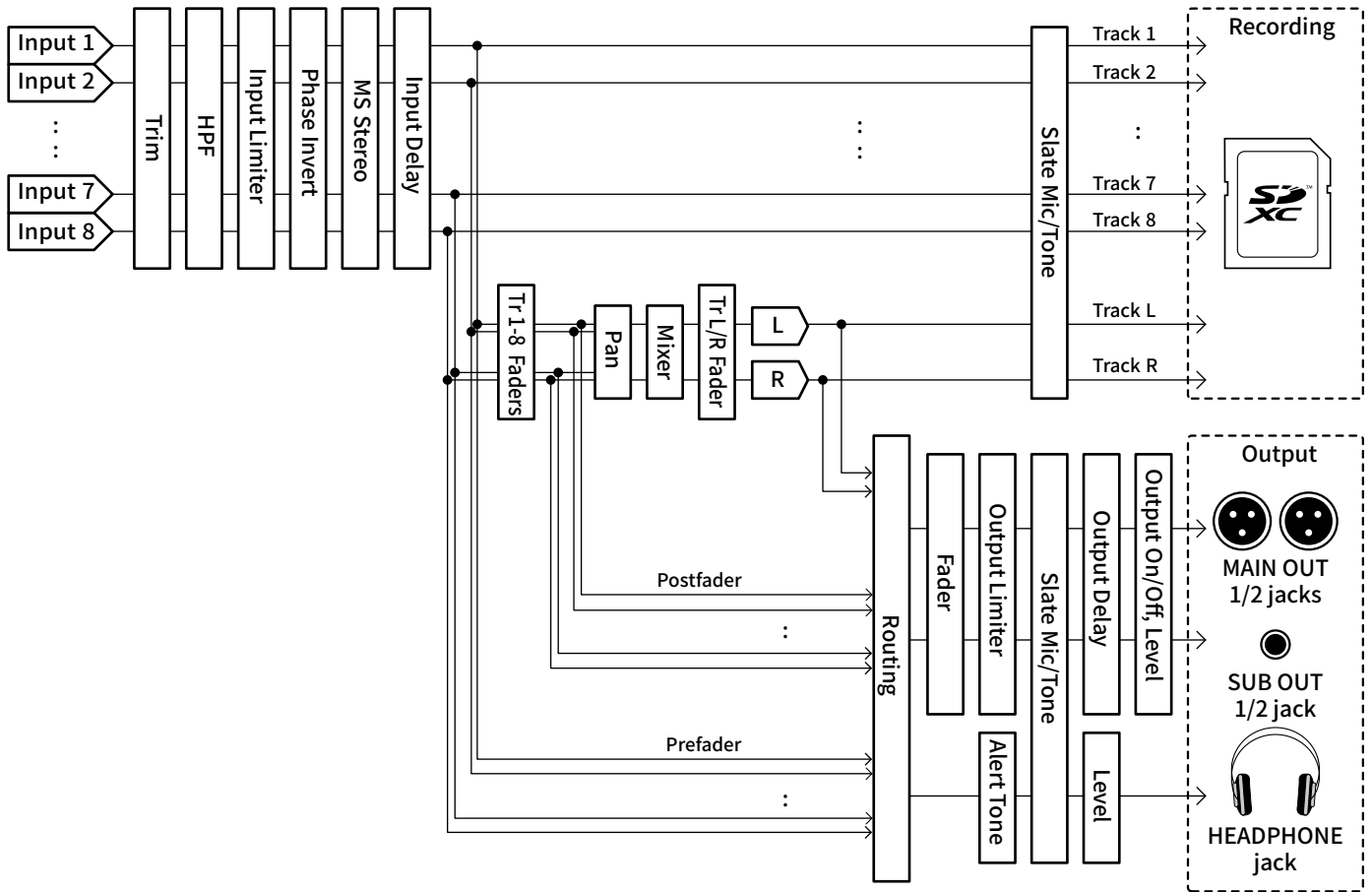

Adjusting the input signal monitoring balance

You can adjust the volume of each input signal when monitoring.

1. Open the mixer on the Home Screen. (→ [Mixer Screen](#))

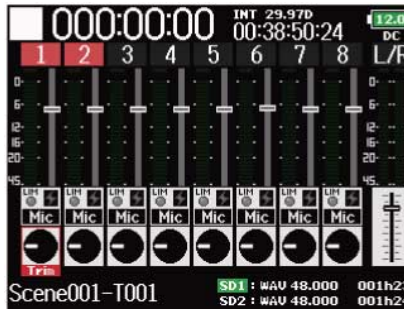

2. Use  to adjust the faders.

NOTE:

- The MAIN OUT 1/2 and SUB OUT 1/2 faders do not affect the levels of the slate mic and slate tone. (→ [Using the slate mic and slate tone](#))
- These volume settings only affect the monitoring signals. They have no effect on recorded data.
- Settings are saved separately for each take that is already recorded and can be changed during playback. (→ [Mixing takes](#))
- Mix settings are not saved with the take when the recorded file format is MP3.

HINT:

- The fader setting range is muted, and -48.0 to +24.0 dB.
- You can turn  to move the cursor, and also adjust the settings of the MAIN OUT 1/2 and SUB OUT 1/2 signals. (→ [Setting output levels](#))

Setting the track knob function (Track Knob Option)

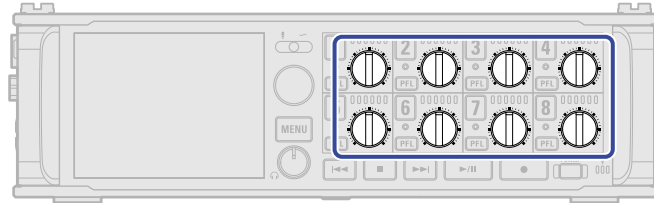

The Home Screen layout and track knob functions can be changed.

You can adjust trim, fader and pan settings with the track knobs by changing the track knob function.





1. Press .

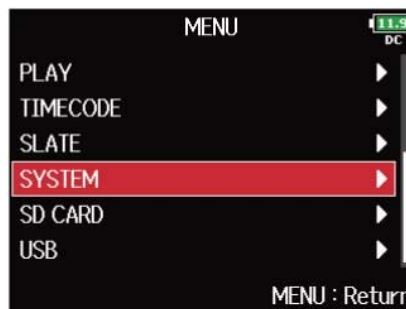

This opens the Menu Screen.

2. Use  to select "SYSTEM", and press .



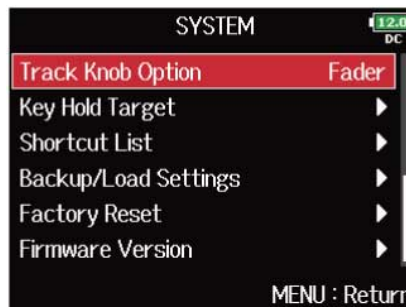





3. Use  to select "Track Knob Option", and press .

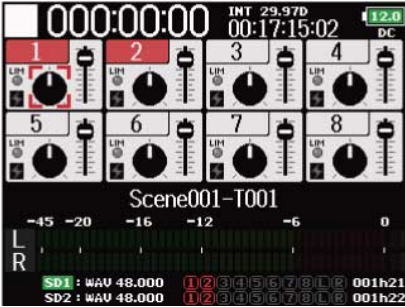

4. Use  to select the track knob function, and press .



| Setting | Explanation |
|---------|--|
| Trim | <p>This track knob function is restricted to changing input levels.</p> <p>1. Open the mixer on the Home Screen. (→ Mixer Screen)</p>  <p>2. Use a track's  to adjust its trim.</p> <hr/> <p>HINT: The panning and fader level can be changed as follows.</p> <ul style="list-style-type: none"> • Move cursor, change setting value: Turn . • Select parameter to change: Press . <hr/> |

| Setting | Explanation |
|---------|---|
| Fader | <p>The track knobs can be used to quickly adjust the fader.</p> <p>1. Open the mixer on the Home Screen. (→ Mixer Screen)</p> <div data-bbox="730 353 1136 663" data-label="Image"> <p>The image shows a digital audio mixer interface. At the top, there is a timer set to 00:00:00 and a display showing 'INT 29.970' and '00:07:02:18'. Below the timer are 8 tracks, numbered 1 through 8. Each track has a vertical fader knob and a small 'L/R' indicator. Below the faders are 8 input source buttons, each labeled 'Mic'. At the bottom of the screen, there is a status bar with the text '210101-T001', 'SD1: WAU 48.000 001h26', and 'SD2: MP3 320kbps 107h41'.</p> </div> <p>2. Use a track's  to adjust its fader.</p> <hr/> <p>HINT: The input level can be changed as follows.</p> <ul style="list-style-type: none"> • Move cursor, change setting value: Turn . • Select parameter to change: Press . <hr/> |



| Setting | Explanation |
|---------|-------------|
|---------|-------------|

Mixer

You can switch the parameter that can be adjusted by using the track knob.

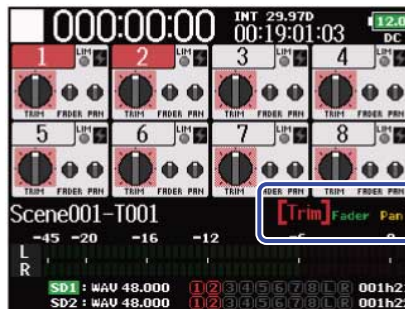
1. Open the mixer on the Home Screen. (→ [Mixer Screen](#))



2. Use  to select the function you want to adjust, and press .

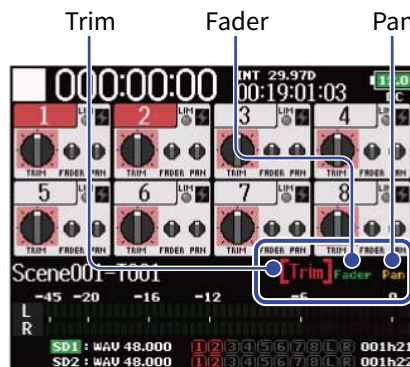

This opens the screen where the selected function can be adjusted.

Trim



You can adjust the trim.

Fader





You can adjust the fader.



Pan





You can adjust the pan.

3. Use  of the track you want to adjust to change its trim, fader or pan setting.

 : Adjust after setting  to the position shown on the display.

 : The setting value is the same as the position of .

Adjusting the L/R track volume

1. Press  +  while the Home Screen is open. (→ [Home Screen](#))
This opens the volume adjustment screen.

NOTE:



Shortcuts are disabled during playback.

2. Use  to adjust the volume.



NOTE:

- Volume settings affect the results of recording.
- If only the L/R track is recorded, the L/R track fader setting for the take will be saved as 0 dB.

3. When finished adjusting, press  or  + .

NOTE:

This is only enabled when “Track Knob Option” is not set to “Fader”. (→ [Setting the track knob function \(Track Knob Option\)](#))

When set to “Fader”, you can adjust by using  to select.

Monitoring the input signals of specific tracks (PFL/SOLO)

You can monitor the input signals of specified tracks.

Even tracks that have not been set to record can be input to the PFL Screen and their input sounds monitored.

This is convenient when using tracks as return inputs.

1. Press **[PFL]** on the tracks that you want to monitor.

The selected track keys will light orange, and the PFL Screen will open. (→ [PFL Screen](#))

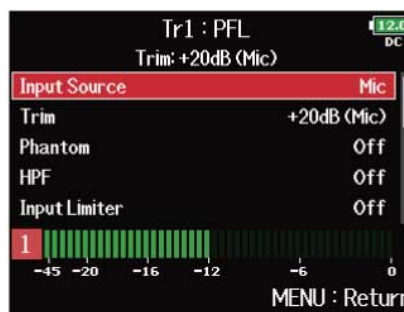

NOTE:

This does not change the signals output from MAIN OUT and SUB OUT.

HINT:

- You can select either prefader listening (PFL) or postfader solo (SOLO) for monitoring. (→ [Setting the monitoring sound on the PFL Screen \(PFL Mode\)](#))
- You can also make input settings, including source and level, for the track that is monitored. (→ [PFL Screen](#))

2. Press **[PFL]** or **[MENU]** for the monitored tracks.



Open the Home Screen.

Setting the input source (Input Source)

Follow these procedures to set the input source of each track.

1. Press .

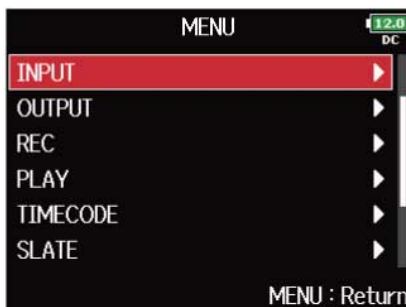

This opens the Menu Screen.

2. Use  to select "INPUT", and press .

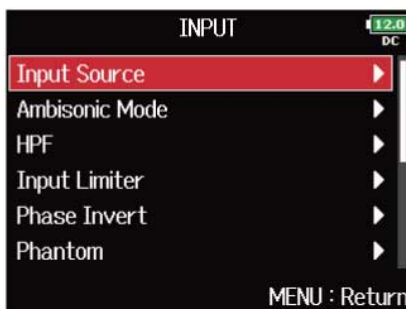

3. Use  to select "Input Source", and press .



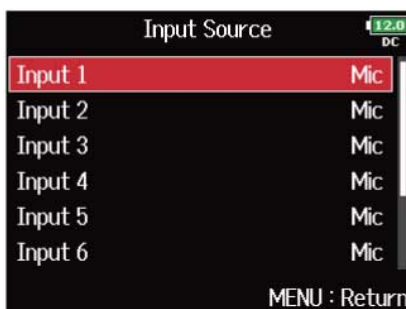

4. Use  to select a track, and press .



HINT:

Select "All" to set all the tracks at the same time.

5. Use  to select the input source, and press .

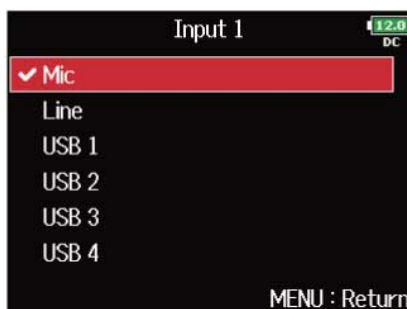

| Setting | Explanation |
|----------------------------|--|
| Mic | Select this when connecting a mic or other equipment with a low input level. |
| Line | Select this when connecting line level equipment. The input level will be reduced 20 dB compared to when "Mic" is selected. |
| USB 1、 USB 2、 USB 3、 USB 4 | When "Audio Interface with Rec" is set to "On", computer output signals are treated as input signals. (→ Using SD card recording and audio interface functions at the same time (Audio Interface with Rec)) |

NOTE:



When a mic capsule is connected, the Input Source cannot be changed for Inputs 1 and 2.

Setting the monitoring sound on the PFL Screen (PFL Mode)



On the PFL Screen, you can set the monitored sound to be either prefader listening (PFL) or postfader solo (SOLO). (→ [Monitoring the input signals of specific tracks \(PFL/SOLO\)](#))

1. Press .

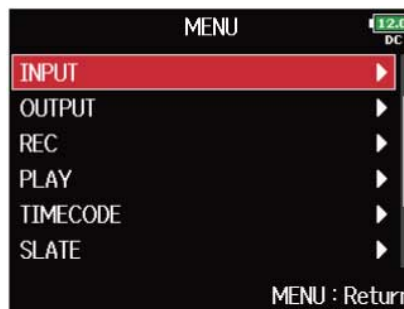

This opens the Menu Screen.

2. Use  to select "INPUT", and press .

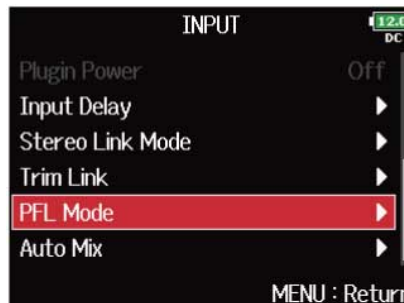

3. Use  to select "PFL Mode", and press .



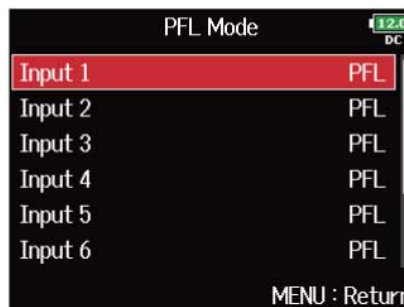

4. Use  to select a track, and press .



HINT:

Select "All" to set all the tracks at the same time.

5. Use  to select the mode, and press .



| Setting | Explanation |
|---------|------------------------------|
| PFL | Monitor the prefader sound. |
| SOLO | Monitor the postfader sound. |

NOTE:

When the PFL Screen is open during playback, the monitoring sound will be post-fader (SOLO) regardless of the setting.

HINT:

The selected mode is shown at the top of the PFL Screen.

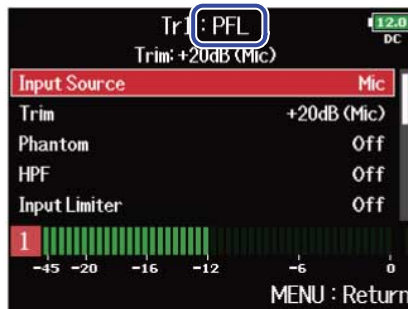



Cutting low-frequency noise (HPF)



The high pass filter can cut low frequencies to reduce the sound of wind, vocal pops and other noise.

1. Press .

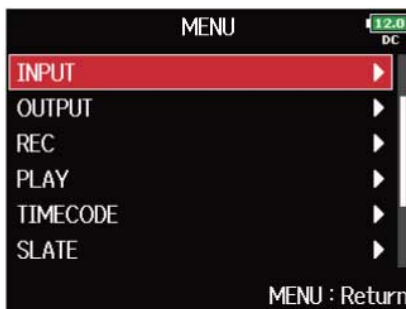

This opens the Menu Screen.

2. Use  to select "INPUT", and press .

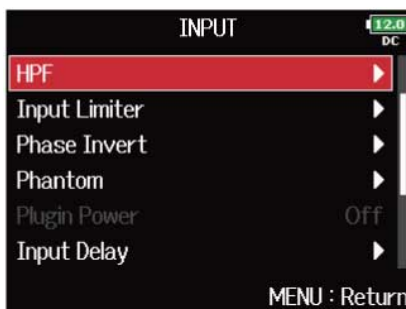

3. Use  to select "HPF", and press .



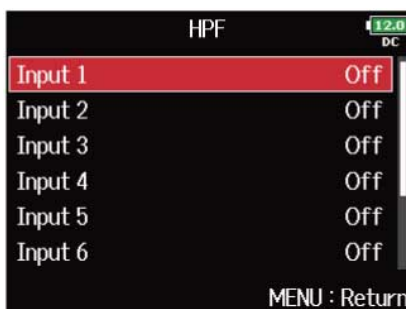

4. Use  to select a track, and press .



HINT:

Select "All" to set all the tracks at the same time.

5. Use  to set the cutoff frequency, and press  .



HINT:

This can be set to "Off" or between 10 and 240 Hz.

Using the input limiter (Input Limiter)

The limiter can prevent distortion by controlling input signals that have excessively high levels.

When the limiter is ON, if the input signal level exceeds the set threshold value, the signal level will be suppressed to prevent the sound from distorting. The attack time is how long after the signal exceeds the threshold before the limiter starts operating. The release time is how long after the signal goes below the threshold before the limiter stops operating. You can change these two parameters to adjust the sound quality.

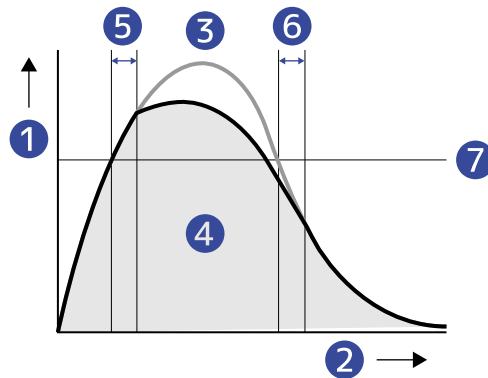

- 1 Level
- 2 Time
- 3 Original signal
- 4 Output signal when Limiter used
- 5 Attack Time
- 6 Release Time
- 7 Threshold



Turning the input limiter on/off

You can turn the input limiter on/off for each track.



You can select an ordinary limiter (Normal) or an optimized limiter that prevents distortion by detecting the maximum level in advance (Advanced).

1. Press .

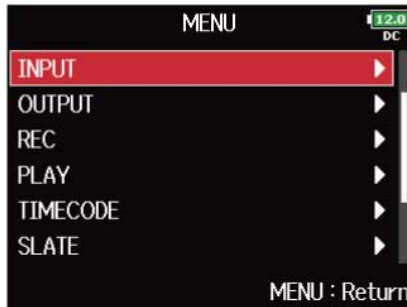

This opens the Menu Screen.

2. Use  to select "INPUT", and press .

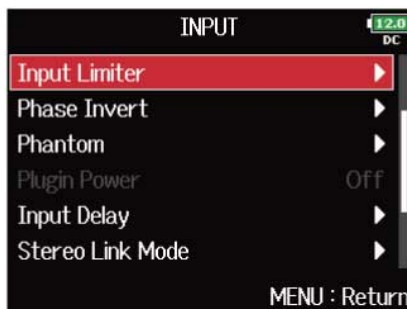

3. Use  to select "Input Limiter", and press .



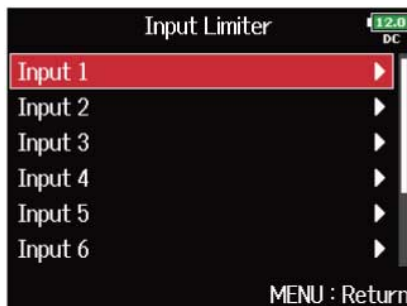

4. Use  to select a track, and press .





HINT:

Select "All" to set all the tracks at the same time.

5. Use  to select "On/Off", and press .



6. Use  to select the setting, and press .

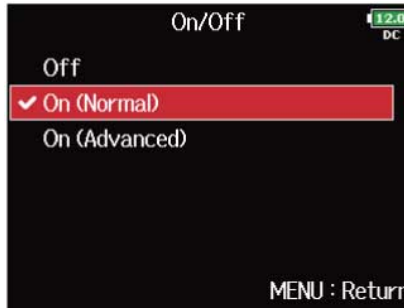

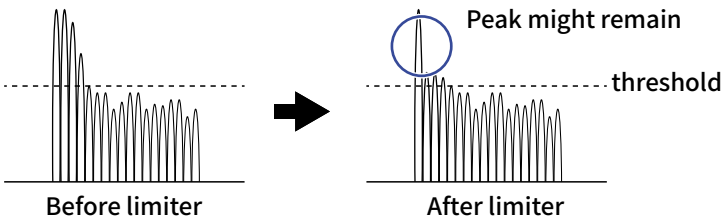
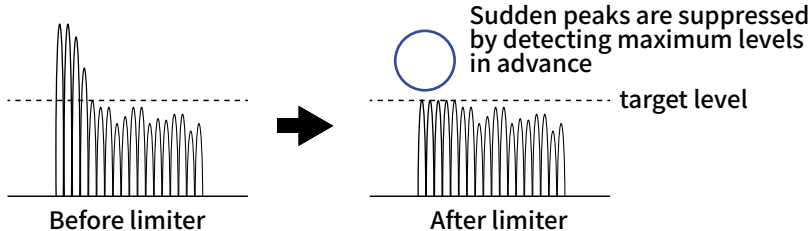
| Setting | Explanation |
|---------------|--|
| Off | This disables the limiter. |
| On (Normal) | <p>This applies an ordinary limiter. The ratio is 20:1.</p>  <p>Before limiter → After limiter</p> <p>For the limiter settings, see "Setting the ordinary limiter (Normal)".</p> |
| On (Advanced) | <p>By detecting the maximum level in advance, this optimized limiter prevents distortion even more than ordinary limiter operation. The ratio is ∞:1, providing increased internal headroom.</p>  <p>Before limiter → After limiter</p> <p>For setting the target output level for the signal, see "Setting the target level".</p> |

NOTE:

- When set to “On (Advanced)”, the input latency of the F8n Pro increases 1 ms. When monitoring sounds being recorded with a mic in real-time, increased latency can cause interference between sound transmitted through the air from the source and the delayed monitored sound, possibly making accurate monitoring of the sounds difficult.
- When set to any value other than “Off”, the Sample Rate cannot be set to 192 kHz. Moreover, when the Sample Rate is set to 192 kHz, only “Off” can be selected. (→ [Setting the sampling rate \(Sample Rate\)](#))

HINT:



- Limiter operation is linked for tracks that have stereo link or MS stereo link enabled. If the signal for either linked channel reaches the threshold, the limiter will operate on both tracks.
- When the limiter is operating, the right-most segment of the level meter and the mixer limiter indicator on the display light yellow.

Setting the ordinary limiter (Normal)

You can make settings for the ordinary limiter by selecting “On (Normal)” in [“Turning the input limiter on/off”](#).

1. Press .

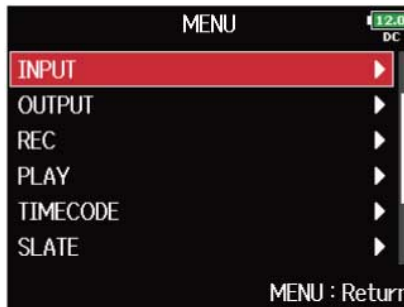

This opens the Menu Screen.

2. Use  to select “INPUT”, and press .

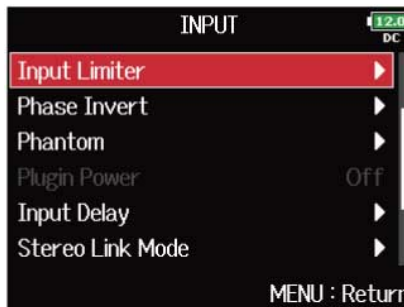

3. Use  to select “Input Limiter”, and press .



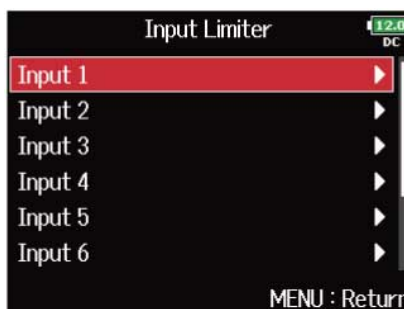

4. Use  to select a track, and press .









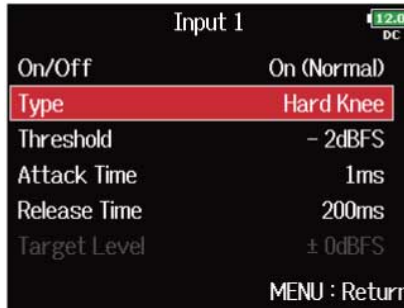



HINT:

Select “All” to set all the tracks at the same time.

5. Use  to select a setting item, and press .

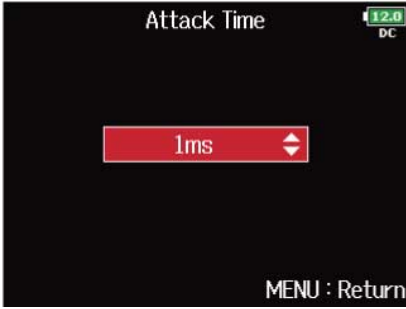

| Setting | Explanation |
|-----------|--|
| Type | <p>This sets the limiter type.</p> <p>1. Use  to select the type, and press .</p> <div data-bbox="839 786 1246 1088" style="text-align: center;"> </div> <ul style="list-style-type: none"> • Hard Knee: Only peaks that exceed the threshold are attenuated. There is no effect below the threshold. • Soft Knee: The limiter gradually affects the signal about 6 dB below the threshold for a gentler effect. |
| Threshold | <p>This sets the level at which the limiter begins operating.</p> <p>1. Use  to adjust the setting, and press .</p> <div data-bbox="839 1476 1246 1778" style="text-align: center;"> </div> <p>This can be set from -16 to -2 dBFS.</p> |



| Setting | Explanation |
|--------------|---|
| Attack Time | <p>This sets the amount of time until limiting starts after the input signal exceeds the threshold.</p> <p>1. Use  to adjust the time, and press  .</p> <div data-bbox="839 405 1246 712" style="text-align: center;">  </div> <p>This can be set from 1 to 4 ms.</p> |
| Release Time | <p>This sets the amount of time until limiting stops after the input signal goes below the threshold.</p> <p>1. Use  to adjust the time, and press  .</p> <div data-bbox="839 983 1246 1290" style="text-align: center;">  </div> <p>This can be set from 1 to 500 ms.</p> |

Setting the target level

When the setting of "[Turning the input limiter on/off](#)" is set to "On (Advanced)", use this to set the target output level for the signal.

1. Press .

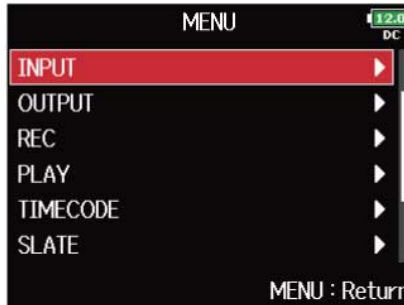

This opens the Menu Screen.

2. Use  to select "INPUT", and press .

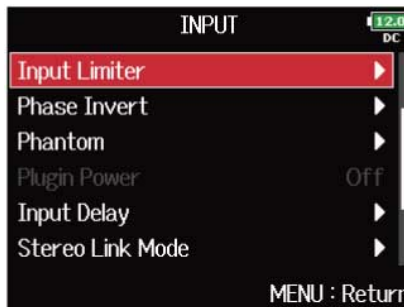

3. Use  to select "Input Limiter", and press .



4. Use  to select a track, and press .

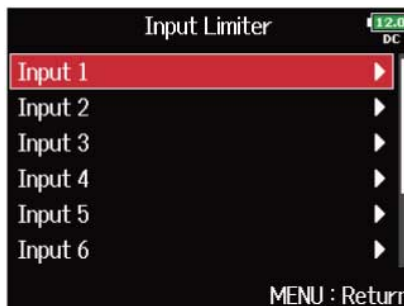



HINT:

Select "All" to set all the tracks at the same time.

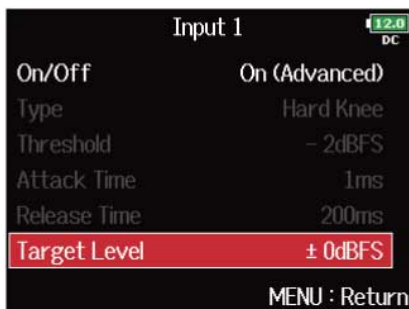
5. Use  to select "Target Level", and press .



6. Use  to adjust the setting, and press .



NOTE:

- This can be set from -16 to 0 dBFS.
- After a signal passes through the limiter, it will not exceed the set target level value.



Inverting the input phase (Phase Invert)

The phase of the input signal can be inverted.



This is useful when sounds cancel each other out due to mic positioning.

1. Press .

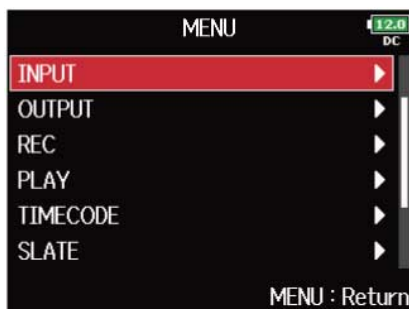

This opens the Menu Screen.

2. Use  to select "INPUT", and press .

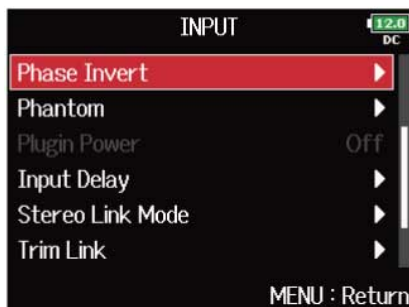

3. Use  to select "Phase Invert", and press .



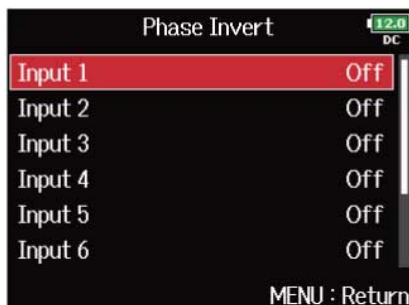

4. Use  to select a track, and press .



HINT:

Select "All" to set all the tracks at the same time.

5. Use  to select "On", and press .



Changing the phantom power settings (Phantom)

The F8n Pro can provide phantom power.

The voltage can be set to +24 V or +48 V and it can be turned on/off for each input separately.

NOTE:

Do not use this function with a device that is not compatible with phantom power. Doing so could damage the device.

HINT:



Phantom power is a function that supplies power to devices that require an external power supply, including some condenser mics.

The standard power is +48 V, but some devices can operate with lower voltages.



Using phantom power

1. Press .

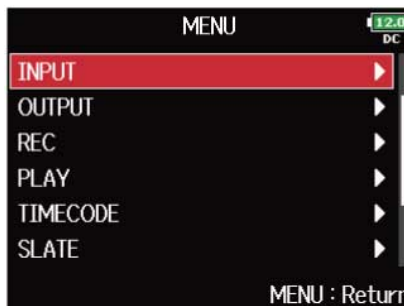

This opens the Menu Screen.

2. Use  to select "INPUT", and press .





3. Use  to select "Phantom", and press .

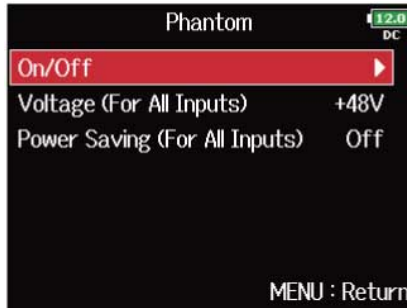

4. Use  to select "On/Off", and press .



5. Use  to select a track, and press .

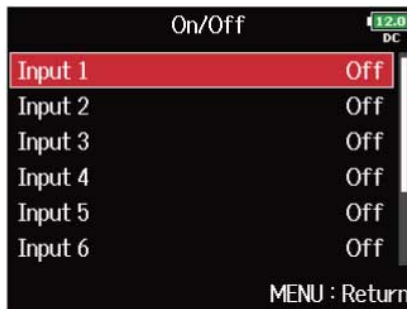

HINT:

Select "All" to set all the tracks at the same time.

6. Use  to select "On", and press .

This turns phantom power on for the track selected in step 5.



NOTE:



When a mic capsule is connected, phantom power is set to "Off" for inputs 1/2.

Setting the voltage



When using mics and other equipment that can operate with voltages less than +48 V, selecting +24 V can reduce power consumption by the F8n Pro.

1. Press .

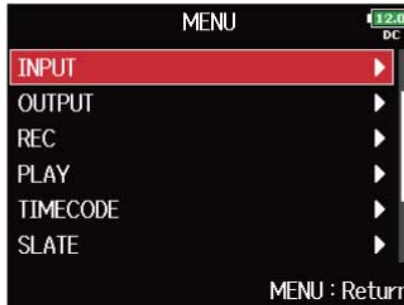

This opens the Menu Screen.

2. Use  to select "INPUT", and press .



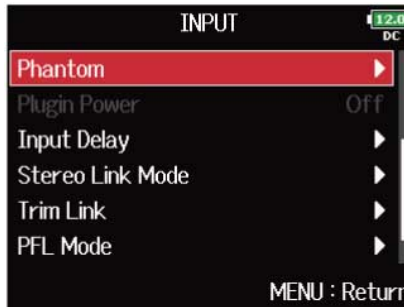

3. Use  to select "Phantom", and press .

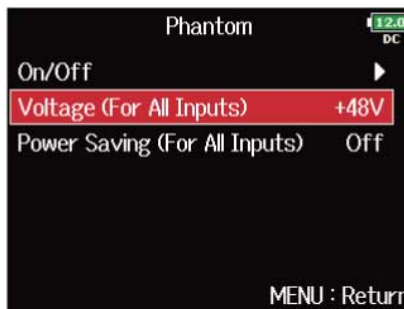

4. Use  to select "Voltage (For All Inputs)", and press .



5. Use  to select the voltage, and press .

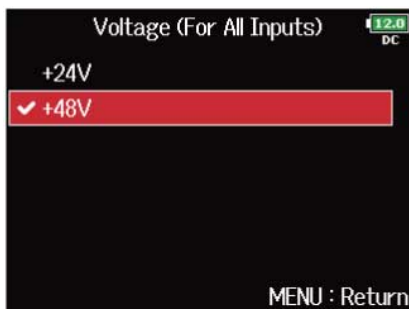

NOTE:



This setting is applied for all inputs.

Disabling phantom power during playback



If mics do not need phantom power during playback, disabling it can reduce F8n Pro power consumption.

1. Press .

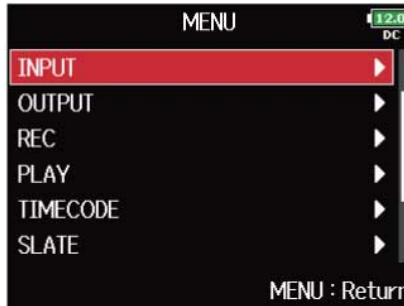

This opens the Menu Screen.

2. Use  to select "INPUT", and press .



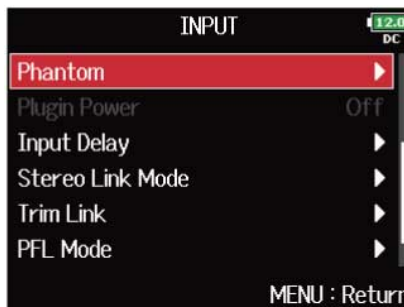

3. Use  to select "Phantom", and press .

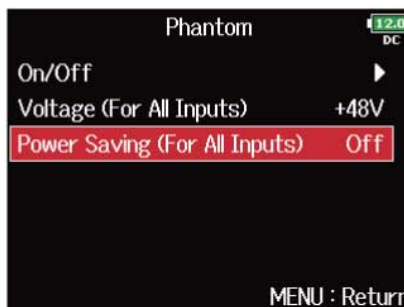

4. Use  to select "Power Saving (For All Inputs)", and press .



5. Use  to select "On (Phantom off during play back)", and press .

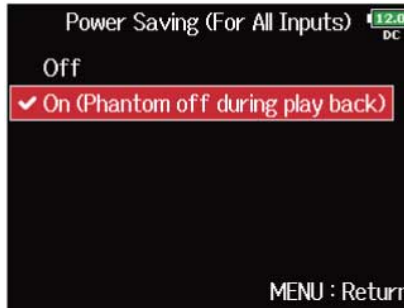

| Setting | Explanation |
|-----------------------------------|---|
| Off | Phantom power is supplied even during playback. |
| On (Phantom off during play back) | Phantom power is not supplied during playback. This can reduce the F8n Pro power consumption. |

NOTE:



This setting is applied for all tracks.

Changing the plugin power setting (Plugin Power)

Make this setting when a mic that is compatible with plug-in power is connected to the mic capsule's MIC/LINE input jack.

1. Press .

This opens the Menu Screen.

2. Use  to select "INPUT", and press .

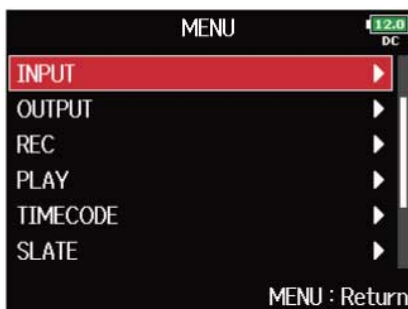

3. Use  to select "Plugin Power", and press .



4. Use  to select "On", and press .

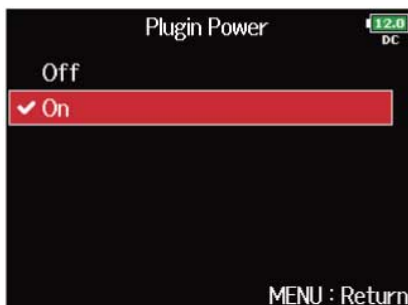

NOTE:



This setting can be changed only when a mic capsule that supports plug-in power is connected.

Delaying input signals (Input Delay)



If there are differences in the timing of input signals, use this function to correct them when recording.

1. Press .

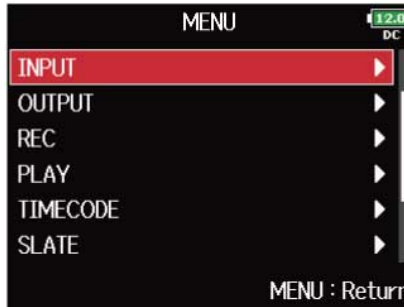

This opens the Menu Screen.

2. Use  to select "INPUT", and press .

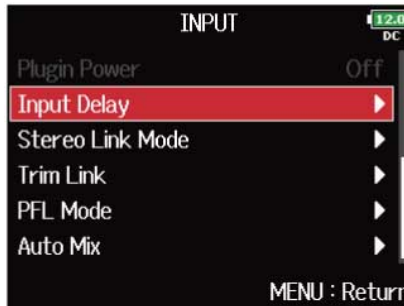

3. Use  to select "Input Delay", and press .



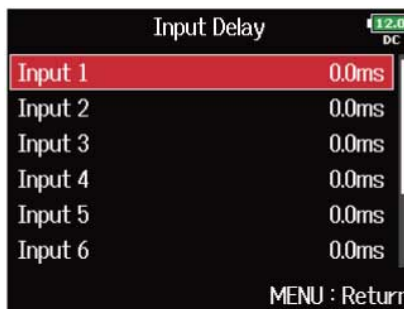

4. Use  to select a track, and press .



HINT:

Select "All" to set all the tracks at the same time.

5. Use  to adjust the delay time, and press .



NOTE:

When Sample Rate is set to 192 kHz, "Input Delay" is disabled. (→ [Setting the sampling rate \(Sample Rate\)](#))

HINT:

This can be set from 0 to 30.0 ms.

Converting mid-side input to ordinary stereo (Stereo Link Mode)

Signals from a mid-side stereo mic input connected to stereo-linked inputs can be converted to an ordinary stereo signal. See [“Linking inputs as a stereo pair”](#) for how to use stereo linking.

Mid-side stereo format overview:

This technique creates a stereo recording from signals input by a directional mid mic that captures sound in the center and a bidirectional side mic that captures sounds from the left and right. Mid-side recording allows you to change the stereo width by the adjusting the level of the side mic.

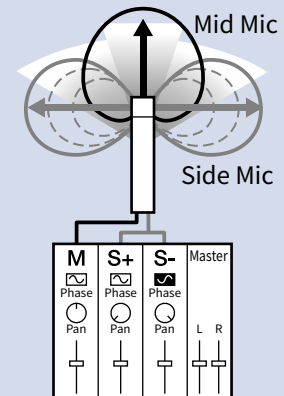

Since this technique can capture a wide stereo image, it is ideal for recording open spaces with numerous sound sources, such as orchestras, live concerts and soundscapes.

Mid-side recording is also extremely effective when you want to be able to control the amount of room ambience in a signal. For this reason, it is often used for live as well as studio recording. In addition, the stereo signal created by this technique is fully mono-compatible, making it especially useful when recording sound for film, video, or broadcast.





1. Press .

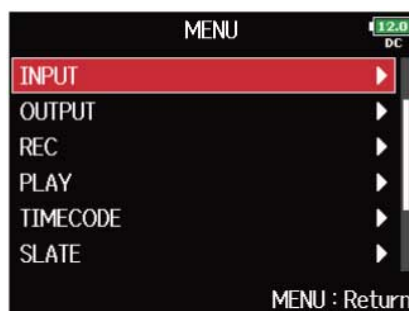

This opens the Menu Screen.

2. Use  to select "INPUT", and press .

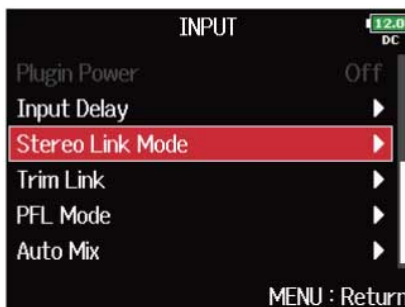

3. Use  to select "Stereo Link Mode", and press .



4. Use  to select a track, and press .

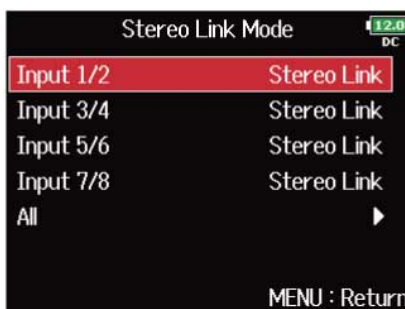

HINT:

Select "All" to set all the tracks at the same time.

5. Use  to select "MS Stereo Link", and press .

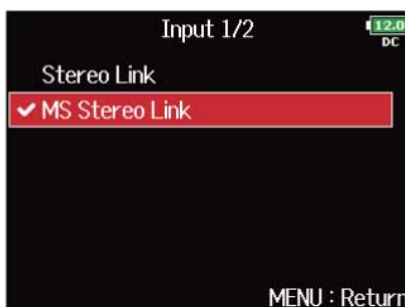

| Setting | Explanation |
|----------------|---|
| Stereo Link | When stereo-linked, inputs are handled normally. |
| MS Stereo Link | When stereo-linked, signals from a mid-side mic are converted to ordinary stereo. |

NOTE:

- When “MS Stereo Link” is selected, odd-numbered inputs are handled as mid signals and even-numbered inputs as side signals.
- The “MS Stereo Link” setting is disabled if a ZOOM mic capsule is connected that cannot have L/R signals routed individually to inputs 1/2.

HINT:



- Use  for each input to adjust the mid/side balance.
- The PFL Screen allows you to adjust the side mic level for inputs 1/2 when a mid-side mic capsule is connected. (→ [PFL Screen](#))

Adjusting the input levels of multiple tracks simultaneously (Trim Link)



The input levels of multiple tracks can be linked and adjusted at the same time.

1. Press .

This opens the Menu Screen.

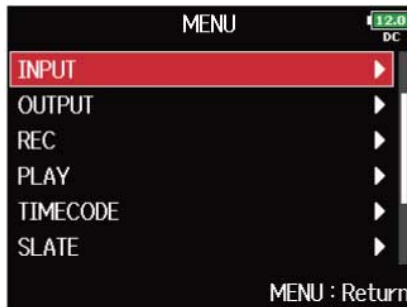
2. Use  to select "INPUT", and press .



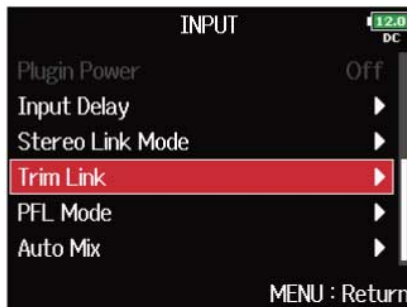

3. Use  to select "Trim Link", and press .



HINT:

You can also open the "Trim Link" screen from the Home Screen by pressing  while pressing and holding



4. Use  to select a track to link, and press .

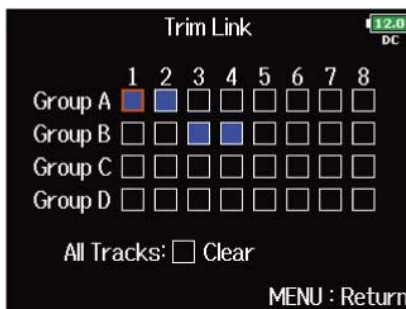

 : Linked

 : Not linked

You can clear all settings by selecting “Clear”.

NOTE:

- A track cannot be in more than one group at a time.
- The input levels of tracks set to “MS Stereo Link” will also be linked if those tracks are put into groups. (→ [Converting mid-side input to ordinary stereo \(Stereo Link Mode\)](#))
- The input levels of tracks that have a mic capsule connected will not be linked even if those tracks are put into groups.

HINT:

- When “Track Knob Option” is not set to “Fader”, you can use  for the first track in a link group to adjust all the input levels within that group at the same time. (→ [Setting the track knob function \(Track Knob Option\)](#))
- Icons for group names are shown next to linked tracks.

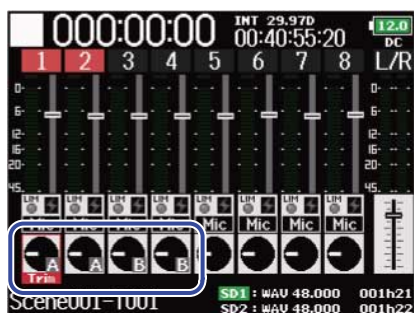

Adjusting the side level of a mid-side mic capsule (Side Mic Level)

You can adjust the side mic level (stereo width) before recording when a mid-side mic capsule is connected.

1. Press **PFL** for track 1 or 2.
This opens the PFL Screen.

2. Use  to select "Side Mic Level", and press .



3. Use  to adjust the side mic level, and press **MENU**.

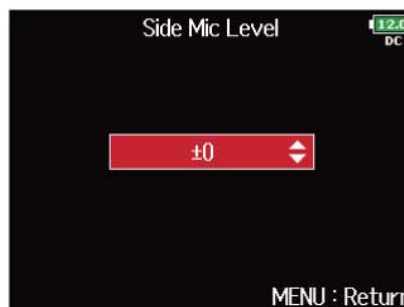

NOTE:

- The more the side mic level is increased, the greater the stereo width.
- When set to "RAW", recording will occur without stereo encoding. The stereo width of audio in RAW format can be adjusted after recording by using "ZOOM MS Decoder" or other plug-in software.
- This can be adjusted only when a mid-side type mic capsule is connected.

HINT:

This can be set to "Off", "RAW" or in a range from -24 to +6 dB.



Changing the automatic mixing setting (Auto Mix)

When using multiple mics to capture audio during a meeting, for example, automatically attenuating the inputs of mics that are not in active use provides the following benefits.



- The likelihood of feedback is reduced.
- Background noise, including fans and crowds is suppressed to a certain level regardless of the number of people using mics.
- Sound quality degradation due to phase differences caused by variations in the distances of multiple mics is reduced.

1. Press .

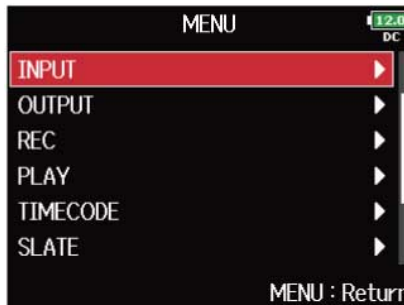

This opens the Menu Screen.

2. Use  to select "INPUT", and press .

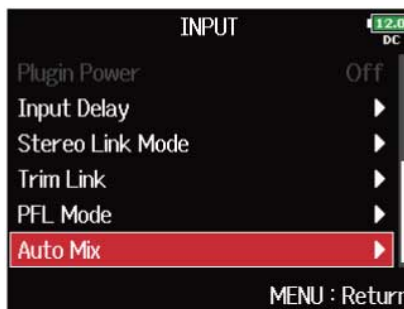

3. Use  to select "Auto Mix", and press .



4. Use  to select a track, and press .

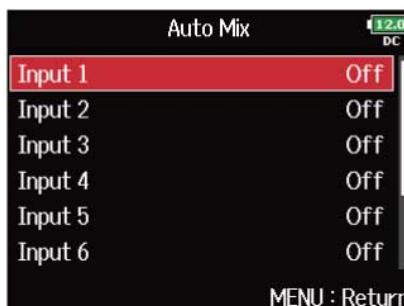

HINT:

Select "All" to set all the tracks at the same time.

5. Use  to select "On", and press .

**NOTE:**

- The following functions and settings cannot be used with this function.
 - The sampling rate cannot be set to 192 kHz. (→ [Setting the sampling rate \(Sample Rate\)](#))
 - The "Ambisonic Mode" format cannot be set to any value other than "Off". (→ [Setting the format of Ambisonic Mode](#))
- When the sampling rate is set to 44.1–48.048 kHz and "Auto Mix" is set to "On", the latency will increase 2 ms. When monitoring sounds being recorded with a mic in real-time, increased latency can cause interference between sound transmitted through the air from the source and the delayed monitored sound, possibly making accurate monitoring of the sounds difficult. (→ [Setting the sampling rate \(Sample Rate\)](#))

HINT:

When "Track Knob Option" is set to "Fader", the fader areas of the meters on the Home Screen show the amount of attenuation for tracks that have "Auto Mix" set to "On". (→ [Setting the track knob function \(Track Knob Option\)](#))

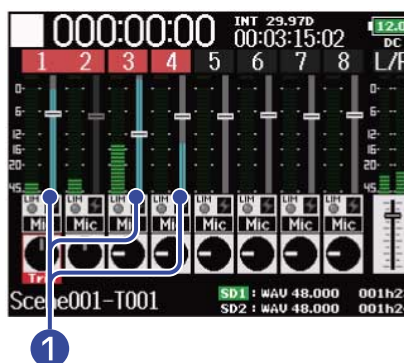



- ① Meters that show the amount of attenuation due to "Auto Mix"
-

Setting the format of Ambisonic Mode

By connecting mics that can output ambisonics A-format signals to Inputs 1–4, audio can be converted to ambisonics B-format and recorded.

1. Press .

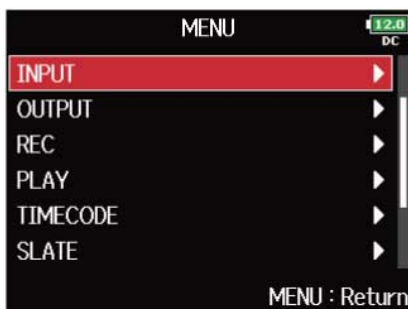

This opens the Menu Screen.

2. Use  to select "INPUT", and press .



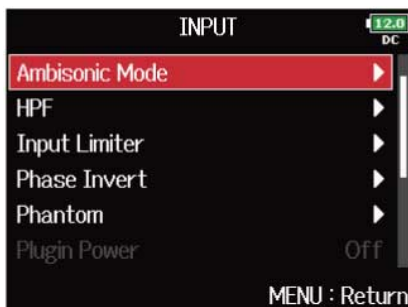

3. Use  to select "Ambisonic Mode", and press .

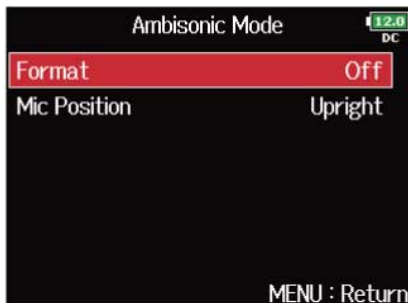

4. Use  to select "Format", and press .



5. Use  to select the format, and press .

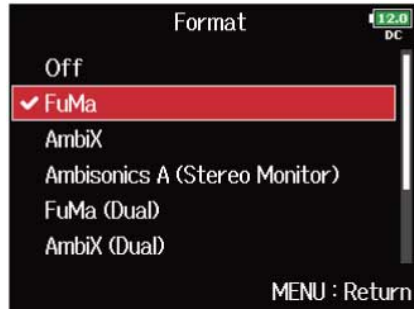

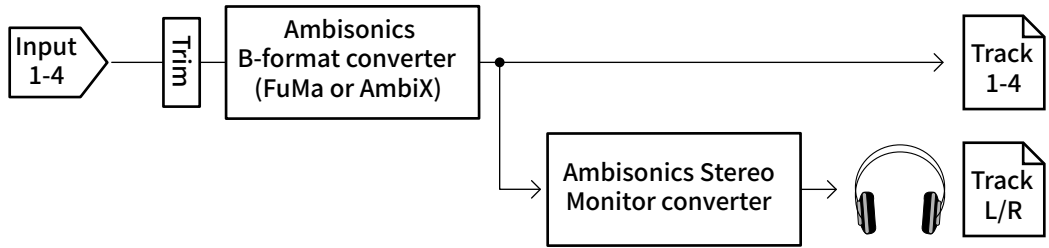
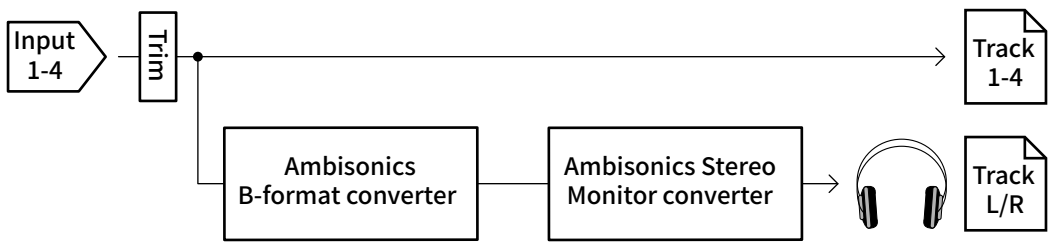
| Setting | Explanation |
|--|--|
| FuMa | This converts the signals from Inputs 1-4 to the ambisonics FuMa B-format, and saves them as a 4-channel polyphonic file. |
| AmbiX | This converts the signals from Inputs 1-4 to the ambisonics AmbiX B-format, and saves them as a 4-channel polyphonic file. |
|  | |
| Ambisonics A (Stereo Monitor) | This saves the signals from Inputs 1-4 as a 4-channel polyphonic file without converting them to an ambisonics B-format. The monitoring signal is converted to ambisonics B-format and then to an ordinary stereo signal. |
|  | |
| FuMa(Dual) | This converts the signals from Inputs 1-4 to the ambisonics FuMa B-format, and saves them as a 4-channel polyphonic file. |
| AmbiX(Dual) | This converts the signals from Inputs 1-4 to the ambisonics AmbiX B-format, and saves them as a 4-channel polyphonic file. |
| FuMa + AmbiX | This converts the signals from Inputs 1-4 to the ambisonics FuMa B-format, and records them to tracks 1-4. It also converts the signals from Inputs 1-4 to the ambisonics AmbiX B-format, and records them to tracks 5-8. These can be recorded at different input levels. |

| Setting | Explanation |
|---------|-------------|
|---------|-------------|

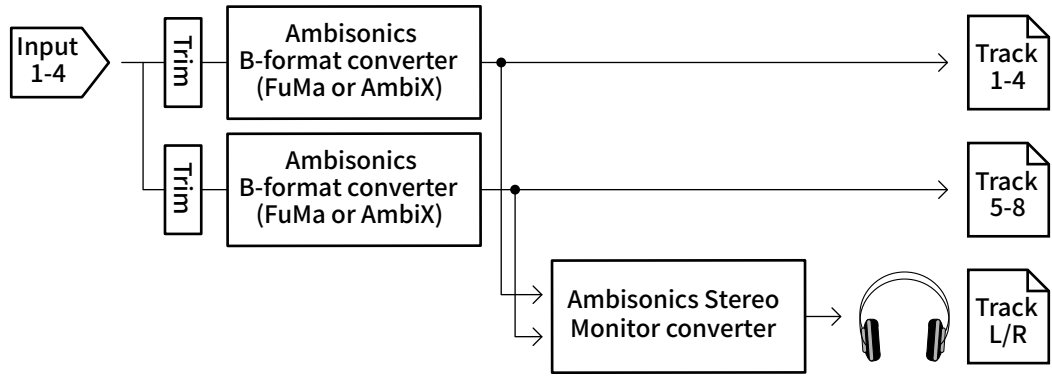

FuMa +
Ambisonics A

This converts the signals from Inputs 1-4 to the ambisonics FuMa B-format, and records them to tracks 1-4. It also records the signals from Inputs 1-4 to tracks 5-8 without converting them to an ambisonics B-format. These can be recorded at different input levels.

AmbiX +
Ambisonics A

This converts the signals from Inputs 1-4 to the ambisonics AmbiX B-format, and records them to tracks 1-4. It also records the signals from Inputs 1-4 to tracks 5-8 without converting them to an ambisonics B-format. These can be recorded at different input levels.

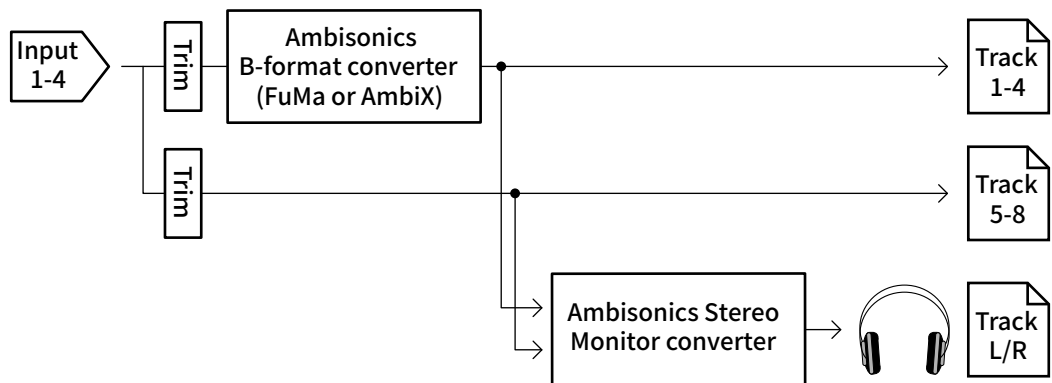

NOTE:

- The sampling rate can only be set to 192 kHz when the format of “Ambisonic Mode” is “Off”. (→ [Setting the sampling rate \(Sample Rate\)](#))
- Ambisonic files are saved as 4-channel polyphonic files, not as mono or stereo files.
- A ZOOM mic capsule can only be used when the format of “Ambisonic Mode” is “Off”.
- The following parameters cannot be set for tracks using “Ambisonic Mode” input.
“Pan”/“Phase Invert”/“Side Mic Level”/“Input Delay”/“Stereo Link”/“Stereo Link Mode”/“Trim Link”
- Files recorded when the format of “Ambisonic Mode” is not “Off” will play back as ambisonic audio sources rather than ordinary 4-channel polyphonic files. For this reason, these tracks cannot be panned or muted during playback.
- When the sampling rate is set to 44.1–48.048 kHz and “Ambisonic Mode” is not set to “Off”, the F8n Pro latency will increase 2 ms. When monitoring sounds being recorded with a mic in real-time, increased latency can cause interference between sound transmitted through the air from the source and the delayed monitored sound, possibly making accurate monitoring of the sounds difficult. (→ [Setting the sampling rate \(Sample Rate\)](#))
- This cannot be used with the “Auto Mix” function. (→ [Changing the automatic mixing setting \(Auto Mix\)](#))

HINT:

- “Ambisonic Mode” can be set during use as an audio interface (Multi Track). (→ [Using as an audio interface \(Audio Interface\)](#))
- Even when “Ambisonic Mode” is not set to “Off”, you can press track **PFL** to monitor their input sounds. When “PFL mode” is set to “PFL”, you can monitor sounds before they are converted to ambisonics B-format. When “PFL mode” is set to “SOLO”, you can monitor sounds after they are converted to ambisonics B-format. (→ [Setting the monitoring sound on the PFL Screen \(PFL Mode\)](#), [Monitoring the input signals of specific tracks \(PFL/SOLO\)](#))
- The input enabled/disabled statuses of the “Ambisonic Mode” input tracks are linked, so the settings of all assigned tracks can be switched simultaneously by pressing any of their track keys.
- The following parameters that can be set on the PFL screen are linked for input tracks using “Ambisonic Mode”. (→ [PFL Screen](#))
“HPF”/“Input Limiter”/“Phantom”/“Fader”/“PFL Mode”/“Input Source”/“Input Level”
- When “Ambisonic Mode” is not set to “Off”, the Home Screen is displayed as follows. (The display changes depending on the “Track Knob Option” setting. (→ [Setting the track knob function \(Track Knob Option\)](#))

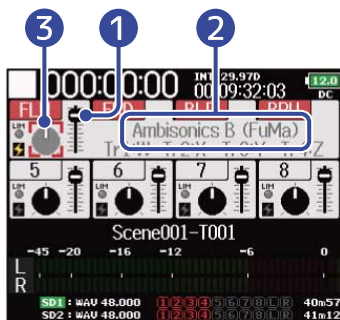
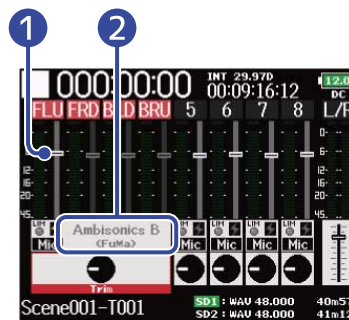
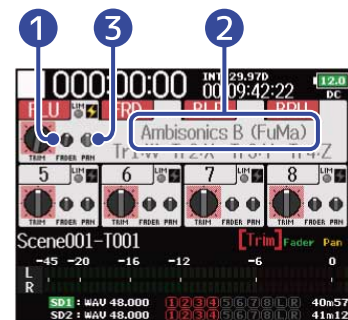
■ When “Track Knob Option” is set to “Trim”**■ When “Track Knob Option” is set to “Fader”****■ When “Track Knob Option” is set to “Mixer”**



- 1 Track 1-4 fader
- 2 Format name
- 3 Panning is disabled

Setting the mic position used for ambisonic recording (Mic Position)

By setting the mic orientation used during ambisonic recording as an F8n Pro parameter, proper positioning can be maintained when converting to ambisonic B format if the mic orientation is changed from upright to upside down or horizontal.

1. Press .

This opens the Menu Screen.

2. Use  to select "INPUT", and press .

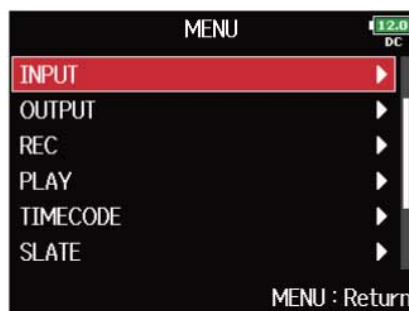

3. Use  to select "Ambisonic Mode", and press .

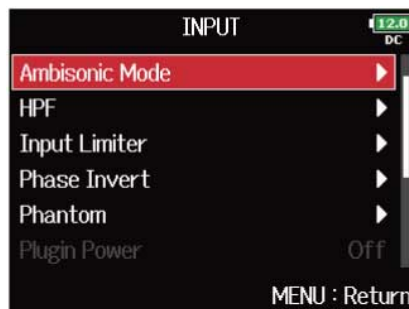

4. Use  to select "Mic Position", and press .

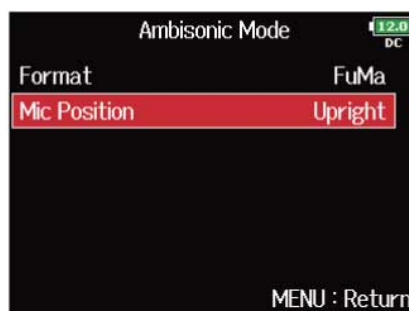

5. Use  to select the mic orientation, and press .

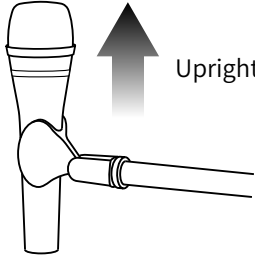
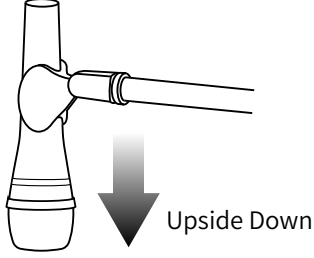
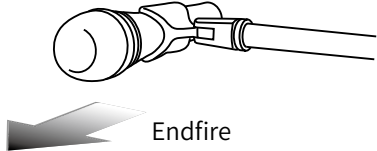

| Setting | Explanation |
|-------------|--|
| Upright | <p>Use this setting to record with the mic upright.</p>  |
| Upside Down | <p>Use this setting to record with the mic upside down.</p>  |
| Endfire | <p>Use this setting to record with the mic oriented horizontally.</p>  |

NOTE:

If this setting and the mic position do not match, sound positioning will not be properly re-created during conversion to ambisonic B format.

HINT:

- Using the mic upright is recommended for ambisonic recording in order to minimize reflections from the floor and the mic itself.
 - When it is difficult to use the mic in an upright orientation, you can place it upside down or pointing forward and change the Mic Position setting accordingly.
-



Making output setting

Setting signals sent to headphones (Headphone Routing)



You can set the type of signal sent to the headphone output to either prefader or postfader for each track. You can also save 10 setting combinations (Setting 1 – Setting 10).

1. Press .

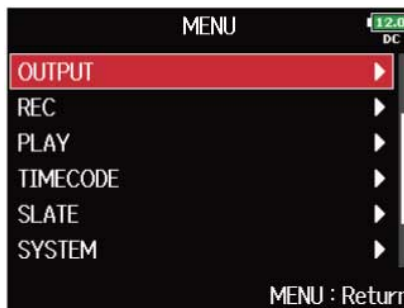

This opens the Menu Screen.

2. Use  to select "OUTPUT", and press .



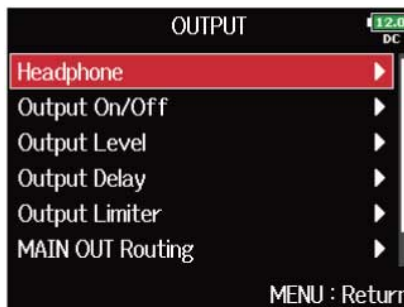

3. Use  to select "Headphone", and press .



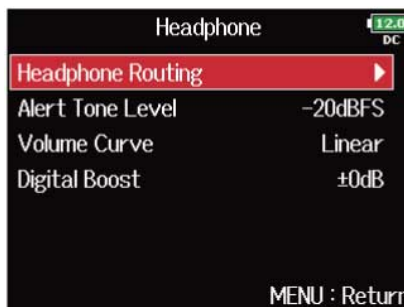

4. Use  to select "Headphone Routing", and press .





5. Use  and  to select the setting you want to change. The selected “Setting” is displayed at the bottom of the screen.



NOTE:



- You can also press  +  to open the “Headphone Routing” screen.
- You can edit and save up to 10 settings.
- Settings are saved automatically.

6. Use  to select the tracks/outputs for headphone routing and press .



1 Tracks routed to the left or right headphone channel

Press  to cycle through the options: “Prefader” → “Postfader” → “Off”.

- : Prefader selected
- : Postfader selected
- : Off

2 Monitoring mid-side stereo signals

Signals from a mid-side stereo mic can be converted to an ordinary stereo signal for monitoring.

- This is disabled for stereo-linked tracks that have “Stereo Link Mode” set to “MS Stereo Link”. (→ [Converting mid-side input to ordinary stereo \(Stereo Link Mode\)](#))
- This is only enabled for tracks that have a mid-side microphone or mid-side mic capsule connected and the “Side Mic Level” set to RAW. (→ [Adjusting the side level of a mid-side mic capsule \(Side Mic Level\)](#))

- When mid-side stereo monitoring is enabled, the prefader tracks will be routed automatically to the headphone channels, with the odd-numbered to the left and the even-numbered to the right. In this case, the routing cannot be changed manually.

3 Prefader setting

This sets tracks 1–8 to prefader.

This deactivates mid-side stereo monitoring.

4 Postfader setting

This cycles through the following options.

- Changes tracks 1–8 to postfader (cancels others)
- Changes L/R to postfader (cancels others)
- Changes M1/M2 to postfader (cancels others)
- Changes S1/S2 to postfader (cancels others)
- Changes U1–U4 to postfader (cancel others)

5 Mono mix

This makes the headphone output mono.

6 All Clear

This clears all settings.

NOTE:

- When “Audio Interface with Rec” is set to “On”, USB tracks 1–4 can be assigned. (→ [Using SD card recording and audio interface functions at the same time \(Audio Interface with Rec\)](#))
- Only postfader can be selected for L/R, MAIN OUT 1/2, SUB OUT 1/2 and USB 1–4 tracks.
- You cannot select the 1–8, L/R, MAIN OUT 1/2, SUB OUT 1/2 and USB 1–4 tracks at the same time. Selecting one will deselect any other.

7. Press .

Outputting alerts through headphones (Alert Tone Level)



The volume can be adjusted for alerts output to headphones when, for example, recording starts and stops.

1. Press .

This opens the Menu Screen.

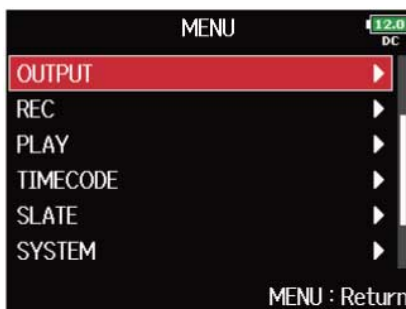
2. Use  to select "OUTPUT", and press .



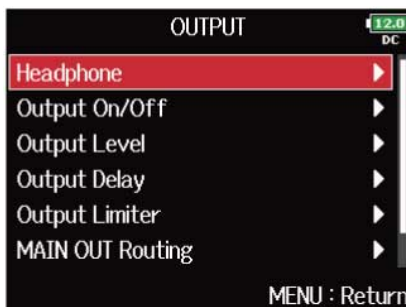

3. Use  to select "Headphone", and press .

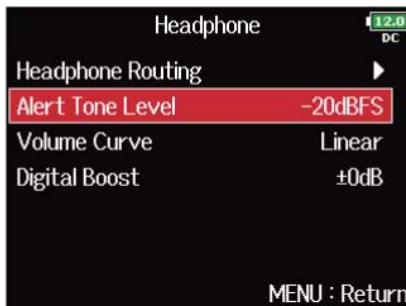

4. Use  to select "Alert Tone Level", and press .



5. Use  to adjust the volume, and press .



HINT:

- This can be set to "Off" or between -48 and -12 dBFS.
 - When set to "Off", no alerts will be output.
-

■ Alert sound conditions and types



| Alert sound condition | Sound type |
|------------------------|--------------------------------------|
| Remaining battery low | 880 Hz tone 4 times every 30 seconds |
| Recording starting | 1000 Hz tone 1 time |
| Recording stopping | 880 Hz tone 2 times |
| Recording not possible | 880 Hz tone 3 times |

Setting the headphone output Volume Curve



The volume curve used when adjusting the headphone volume knob can be set.

1. Press .

This opens the Menu Screen.

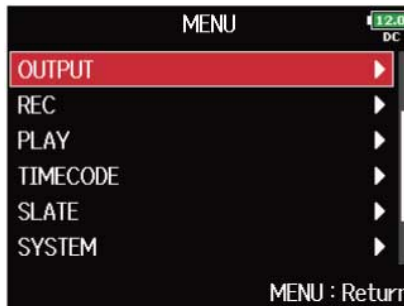
2. Use  to select "OUTPUT", and press .



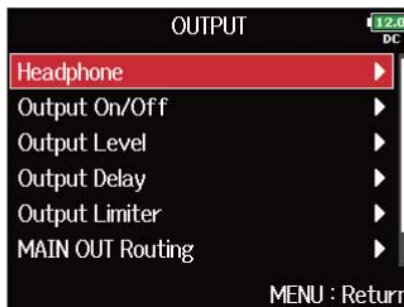

3. Use  to select "Headphone", and press .

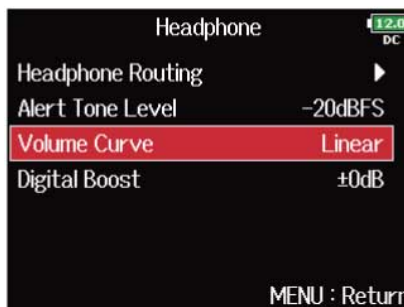

4. Use  to select "Volume Curve", and press .



5. Use  to select the volume curve, and press .

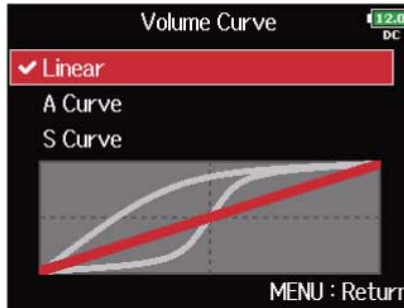



| Setting | Explanation |
|---------|--|
| Linear | The volume will change evenly from the minimum value to the maximum value. |
| A Curve | The closer the volume is to its minimum position, the more rapidly it will change. |
| S Curve | The closer the volume is to its center position, the more rapidly it will change. |

Boosting headphone output to alleviate interference from recorded sound (Digital Boost)



Boosting the headphone output alleviates the interference of sound waves traveling through the air with the headphone monitoring signal, enabling more accurate monitoring of the sound being recorded.

1. Press .

This opens the Menu Screen.

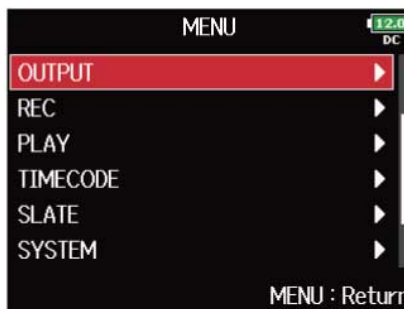
2. Use  to select "OUTPUT", and press .



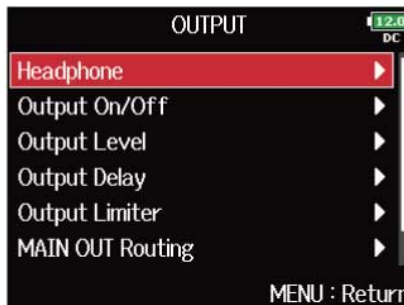

3. Use  to select "Headphone", and press .

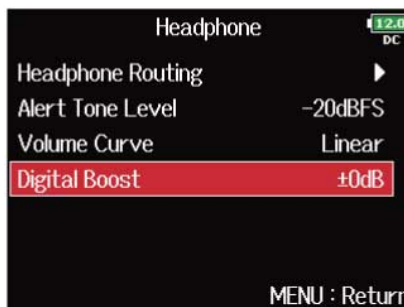

4. Use  to select "Digital Boost", and press .



5. Use  to adjust the amount of boost, and press  .



NOTE:

In situations where the sound being recorded can be heard at the headphone monitoring position, sound waves traveling through the air can interfere with the sound heard from the headphones, altering the monitored sound. The more the sound heard through the headphones is delayed and the lower its volume, the greater the impact of the sound waves.

“Digital Boost” adds a set boost volume to the adjusted headphone volume level, reducing the impact of the sound waves that travel through the air.

HINT:



The amount of boost can be set from 0 to +24 dB.

Disabling outputs (Output On/Off)

By disabling outputs that you are not using, you can reduce power consumption and increase the length of operation time when using batteries.

1. Press .

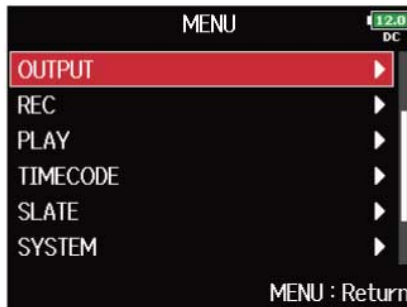

This opens the Menu Screen.

2. Use  to select "OUTPUT", and press .

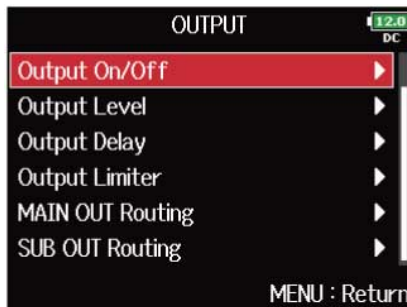

3. Use  to select "Output On/Off", and press .



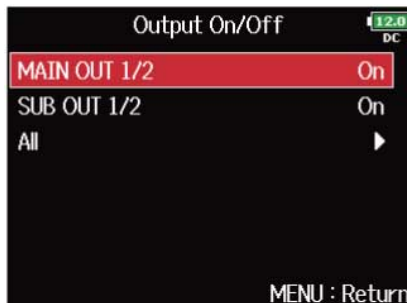

4. Use  to select the output, and press .



HINT:

Select "All" to set all outputs at the same time.

5. Use  to select "Off", and press .





Setting the standard output level (Output Level)



The standard output level can be changed.

1. Press .

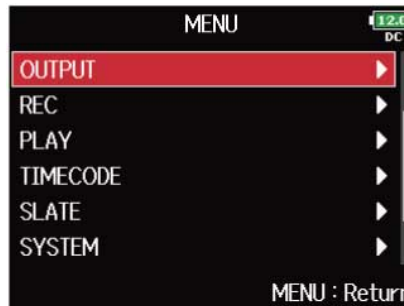

This opens the Menu Screen.

2. Use  to select "OUTPUT", and press .



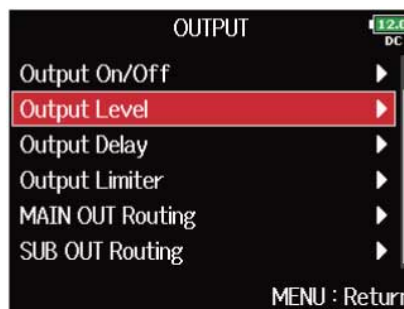

3. Use  to select "Output Level", and press .

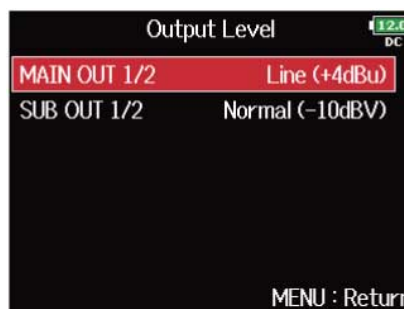

4. Use  to select the output, and press .



5. Use  to set the standard output level, and press .

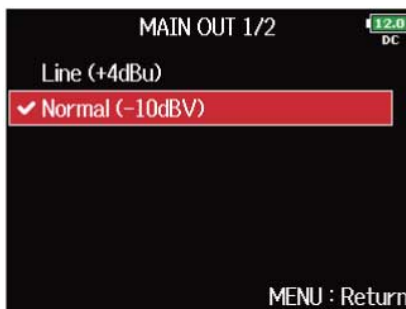



| Setting | Explanation |
|------------------|---|
| Line (+4 dBu) | This sets the standard level to +4 dBu. Only MAIN OUT1/2 can be selected. |
| Normal (-10 dBV) | This sets the standard level to -10 dBV. |
| Mic (-40 dBV) | This sets the standard level to -40 dBV. Only SUB OUT1/2 can be selected. |

Setting output levels

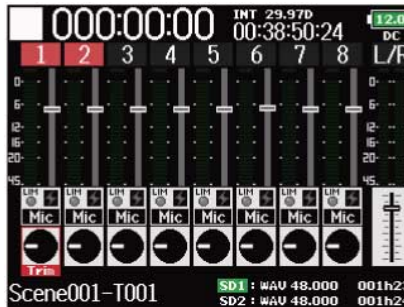

The MAIN OUT 1/2 and SUB OUT 1/2 levels can be changed.

1. Open the mixer on the Home Screen. (→ [Mixer Screen](#))



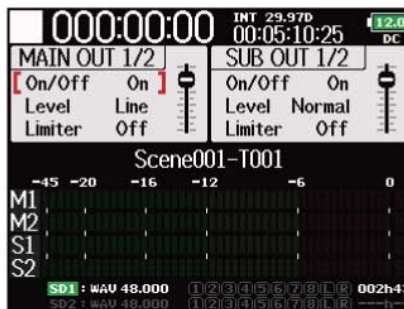

2. Use  to open the MAIN OUT 1/2 and SUB OUT 1/2 settings screen.

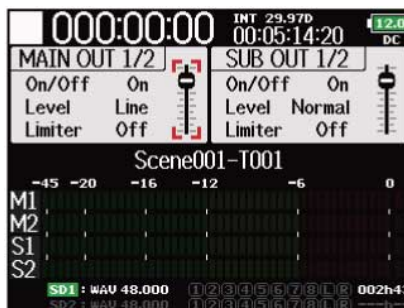

3. Use  to select a fader, and press .



4. Use  to adjust the output level, and press .

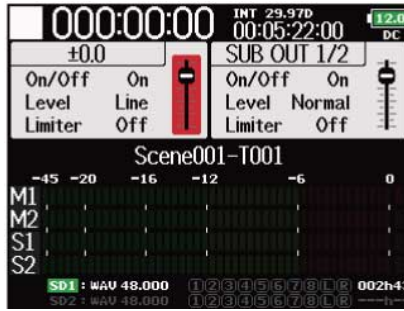

HINT:



- This can be set to "Mute" or from -48.0 to +12.0 dB.
 - You can also check and adjust various output settings on the MAIN OUT/SUB OUT setting screen. (→ [MAIN/SUB OUT Setting Screen](#))
-

Delaying output signals (Output Delay)



By delaying audio outputs, you can correct timing differences for signals input to other devices from the F8n Pro.

1. Press .

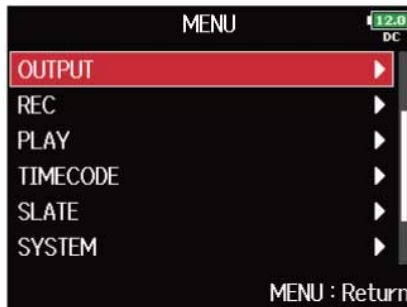

This opens the Menu Screen.

2. Use  to select "OUTPUT", and press .

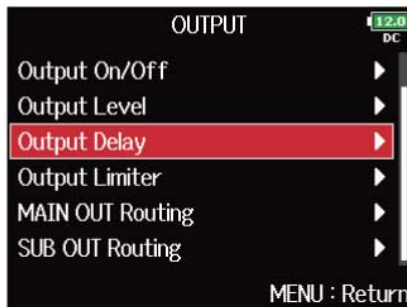

3. Use  to select "Output Delay", and press .



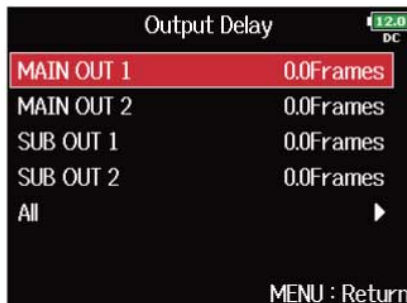

4. Use  to select the output, and press .



HINT:

Select "All" to set all outputs at the same time.

5. Use  to adjust the delay in frames, and press .

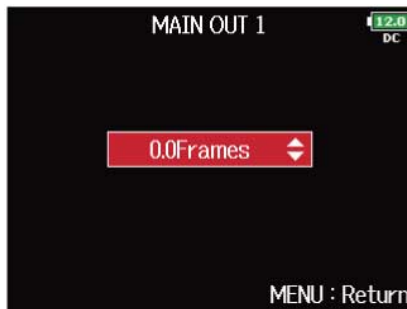

NOTE:

- The delay in milliseconds depends on the frame rate of the selected timecode.
- When Sample Rate is set to 192 kHz, "Output Delay" is disabled. (→ [Setting the sampling rate \(Sample Rate\)](#))

HINT:

This can be set from 0.0 to 10.0 frames.

Using the output limiter (Output Limiter)

Using a limiter on the output can protect devices connected to the output jacks.

HINT:



For details about the effect of the limiter, see [“Using the input limiter \(Input Limiter\)”](#).

Turning the output limiter on/off

You can turn the output limiter on/off for each output.

1. Press .

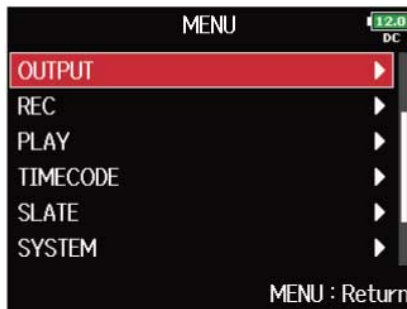

This opens the Menu Screen.

2. Use  to select “OUTPUT”, and press .

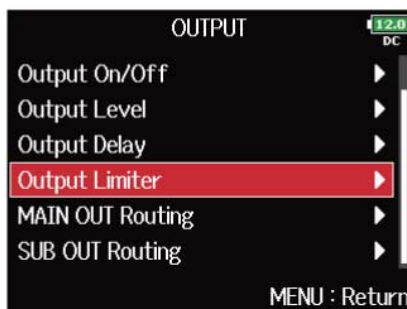

3. Use  to select “Output Limiter”, and press .



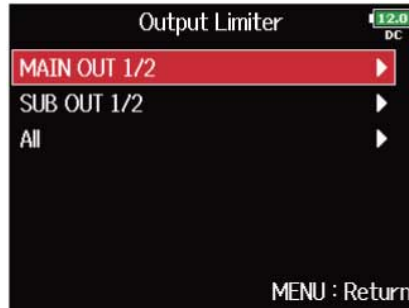

4. Use  to select the output, and press .





HINT:

Select "All" to set all outputs at the same time.

5. Use  to select "On/Off", and press .



6. Use  to select "On" or "Off", and press .

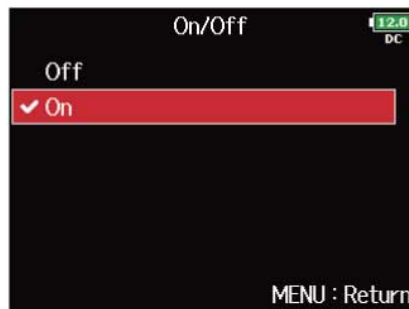



For limiter settings, see ["Setting the output limiter"](#).

Setting the output limiter

1. Press .

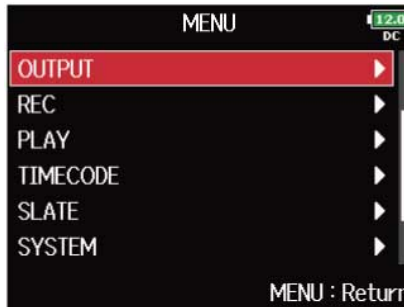

This opens the Menu Screen.

2. Use  to select "OUTPUT", and press .

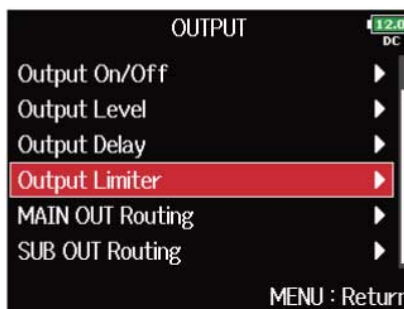

3. Use  to select "Output Limiter", and press .



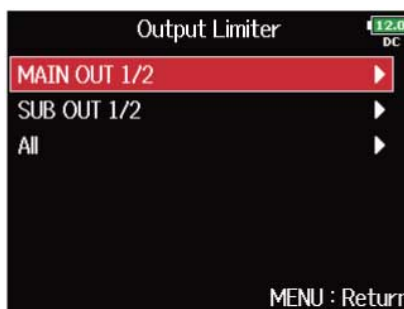

4. Use  to select the output, and press .









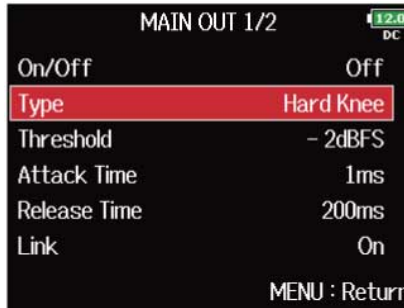





HINT:

Select "All" to set all outputs at the same time.

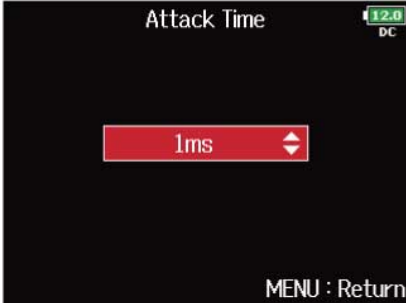
5. Use  to select a setting item, and press .



| Setting | Explanation |
|-----------|---|
| Type | <p>This sets the limiter type.</p> <p>1. Use  to select the type, and press .</p> <div data-bbox="839 786 1246 1088" style="border: 1px solid black; padding: 5px; margin: 10px 0;"> </div> <ul style="list-style-type: none"> • Hard Knee: Only peaks that exceed the threshold are attenuated. There is no effect below the threshold. • Soft Knee: The limiter gradually affects the signal about 6 dB below the threshold for a gentler effect. |
| Threshold | <p>This sets the level at which the limiter begins operating.</p> <p>1. Use  to adjust the setting, and press .</p> <div data-bbox="839 1473 1246 1776" style="border: 1px solid black; padding: 5px; margin: 10px 0;"> </div> <p>This can be set from -16 to -2 dBFS.</p> |



| Setting | Explanation |
|--------------|--|
| Attack Time | <p>This sets the amount of time until limiting starts after the input signal exceeds the threshold.</p> <p>1. Use  to adjust the time, and press  .</p> <div data-bbox="839 405 1248 712" style="text-align: center;">  </div> <p>This can be set from 1 to 4 ms.</p> |
| Release Time | <p>This sets the amount of time until limiting stops after the input signal goes below the threshold.</p> <p>1. Use  to adjust the time, and press  .</p> <div data-bbox="839 983 1248 1290" style="text-align: center;">  </div> <p>This can be set from 1 to 500 ms.</p> |
| Link | <p>The limiter can be linked or applied separately to MAIN OUT 1 and MAIN OUT 2, as well as to SUB OUT 1 and SUB OUT 2.</p> <p>1. Use  to select "Off", and press  .</p> <div data-bbox="839 1561 1248 1868" style="text-align: center;">  </div> <ul style="list-style-type: none"> • Off: Separates limiter operation. • On: Links limiter operation. If the signal for either linked signal reaches the threshold, the limiter will operate on both channels. |

Selecting signals sent to the main outputs (MAIN OUT Routing)



You can send either prefader or postfader signals for each track to the main outputs.

1. Press .

This opens the Menu Screen.

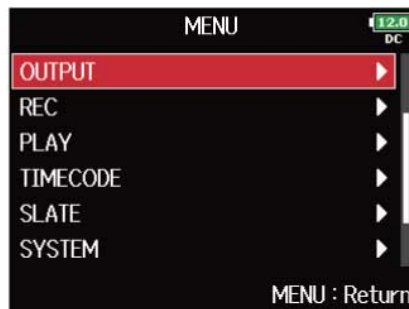
2. Use  to select "OUTPUT", and press .



3. Use  to select "MAIN OUT Routing", and press .

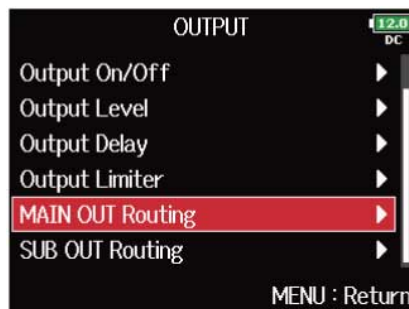

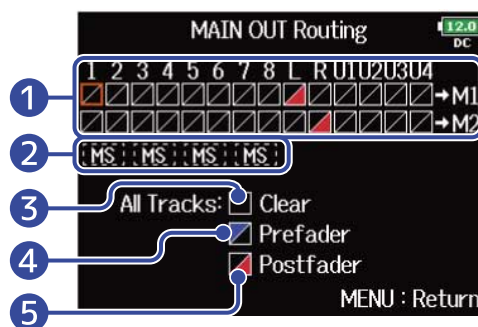

4. Use  to select the track for MAIN OUT 1 or MAIN OUT 2 routing, and press .



- 1 Tracks routed to MAIN OUT 1 or MAIN OUT 2

Press  to cycle through the options: "Prefader" → "Postfader" → "Off".

- : Prefader selected

- : Postfader selected
- : Off

2 Mid-side stereo signal monitoring

This converts input track stereo signals to mid-side stereo signals for output.

When mid-side stereo monitoring is enabled, the prefader tracks will be routed automatically to MAIN OUT 1/MAIN OUT 2, with the odd-numbered to the MAIN OUT 1 and the even-numbered to the MAIN OUT 2. In this case, the routing cannot be changed manually.

3 All Clear

This clears all settings.

4 Prefader setting

This sets tracks 1–8 to prefader.

5 Postfader setting

This cycles through the following options.

- Change tracks 1–8 to postfader (cancels others)
- Change L/R to postfader (cancels others)
- Change U1–U4 to postfader (cancel others)

NOTE:

- When “Audio Interface with Rec” is set to “On”, USB tracks 1–4 can be assigned. (→ [Using SD card recording and audio interface functions at the same time \(Audio Interface with Rec\)](#))
- Only postfader can be selected for L/R and USB 1–4 tracks.
- You cannot select the 1–8, L/R and USB 1–4 tracks at the same time. Selecting one will deselect any other.



5. Press .

Selecting signals sent to the sub outputs (SUB OUT Routing)



You send either prefader or postfader signals for each track to the sub outputs.

1. Press .

This opens the Menu Screen.

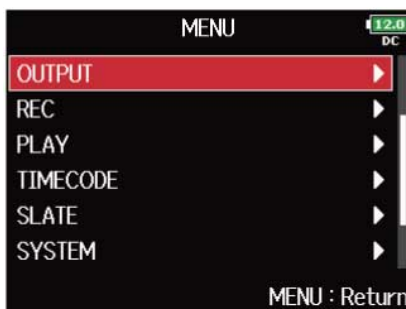
2. Use  to select "OUTPUT", and press .



3. Use  to select "SUB OUT Routing", and press .

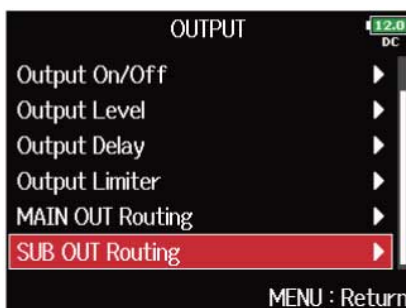

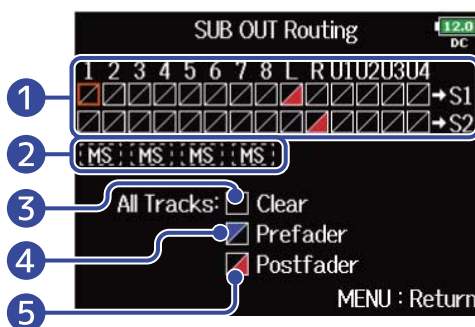

4. Use  to select the track for SUB OUT 1 or SUB OUT 2 routing, and press .



1 Tracks routed to SUB OUT 1 or SUB OUT 2

Press  to cycle through the options: "Prefader" → "Postfader" → "Off".

- : Prefader selected

- : Postfader selected
- : Off

2 Mid-side stereo signal monitoring

This converts input track stereo signals to mid-side stereo signals for output.

When mid-side stereo monitoring is enabled, the prefader tracks will be routed automatically to SUB OUT 1/SUB OUT 2, with the odd-numbered to the SUB OUT 1 and the even-numbered to the SUB OUT 2. In this case, the routing cannot be changed manually.

3 All Clear

This clears all settings.

4 Prefader setting

This sets tracks 1–8 to prefader.

5 Postfader setting

This cycles through the following options.

- Change tracks 1–8 to postfader (cancels others)
- Change L/R to postfader (cancels others)
- Change U1–U4 to postfader (cancel others)

NOTE:

- When "Audio Interface with Rec" is set to "On", USB tracks 1–4 can be assigned. (→ [Using SD card recording and audio interface functions at the same time \(Audio Interface with Rec\)](#))
- Only postfader can be selected for L/R and USB 1–4 tracks.
- You cannot select the 1–8, L/R and USB 1–4 tracks at the same time. Selecting one will deselect any other.

5. Press .

Recording

Enabling recording on SD cards and setting file formats



The recording file format can be set independently for SD CARD slots 1 and 2.

HINT:



- Recording the same content to two cards is possible by using the same settings for both card slots. This function can be used to create a backup in case the sound skips on one card, for example.
- You can also record tracks 1–8 unmixed on one SD card while recording all tracks mixed together as MP3 or WAV data with left and right tracks.

1. Press .

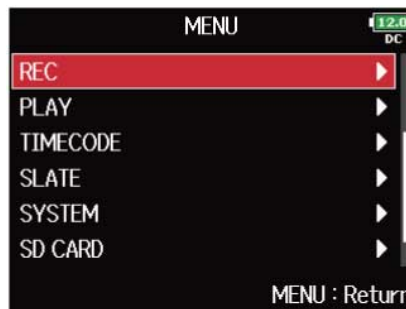

This opens the Menu Screen.

2. Use  to select "REC", and press .

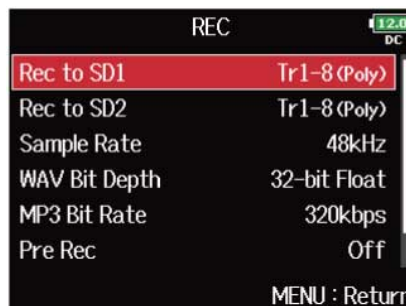

3. Use  to select "Rec to SD1"/"Rec to SD2", and press .



4. Use  to select the file type, and press .



| Setting value | Tracks recorded | Explanation |
|----------------------------------|---------------------------------|--|
| None | - | Nothing is recorded on the SD card. |
| Track1-8 (Poly WAV) | Selected tracks 1-8 | A single (multitrack) file is created that contains audio for multiple tracks. |
| Track1-8 (Mono/Stereo WAV) | | A single mono file is created for each mono track and a single stereo file is created for each stereo track. |
| Track1-8 + L/R (Poly WAV) | Selected tracks 1-8 + L/R track | A single (multitrack) file is created that contains audio for multiple tracks. |
| Track1-8 + L/R (Mono/Stereo WAV) | | A single mono file is created for each mono track and a single stereo file is created for each stereo track. |
| L/R (Stereo WAV) | L/R tracks | A stereo file is created based on the mix created by the internal mixer. |
| L/R (Stereo MP3) | | |

NOTE:

- When recording with the "Mono/Stereo WAV" setting, the audio files are saved in a take folder that is created. (→ [Folder and file structure](#))
- When recording to 2 SD cards simultaneously, files will be saved in take folders with the same name on both cards. Folders will be created automatically if they do not already exist.
- If recording should stop on one SD card because, for example, it runs out of space, recording will continue on the other SD card. At such times, do not remove the card that has stopped recording from the slot. Doing so could damage the card or data.

Selecting inputs and adjusting levels

You can select which of Inputs 1–8 to use.

Inputs will be recorded on tracks with the same numbers. For example, Input 1 will be recorded on track 1 and Input 2 will be recorded on track 2.

Selecting inputs

1. Make the track indicator light by pressing the track key for the number of the input to record.

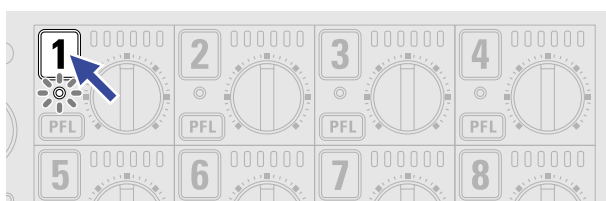

| Track indicator | Track number background color | Explanation |
|-----------------|-------------------------------|------------------------|
| Lit red | Red | The input is enabled. |
| Unlit | Gray | The input is disabled. |

NOTE:

The signals from the inputs selected this way will also be sent to the L/R tracks.

Linking inputs as a stereo pair

1. While pressing track key **1**, press track key **2**.

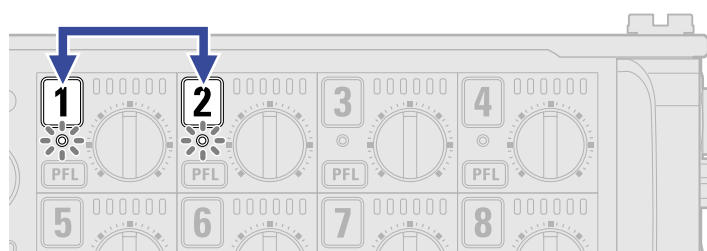



Tracks 1 and 2 will be linked as a stereo track (stereo link).

Repeat the same procedure to disable the stereo link.



HINT:

- The 3/4, 5/6 and 7/8 track pairs can also be stereo-linked in the same way.
- When a mic capsule that allows independent L and R input selection is connected, stereo-linking can also be enabled and disabled for those tracks.

Adjusting input levels

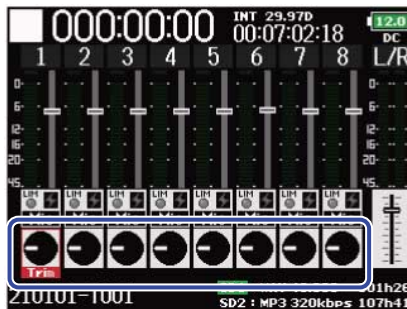
1. Use  to select a track, and press .



2. Use  to adjust the input level, and press .

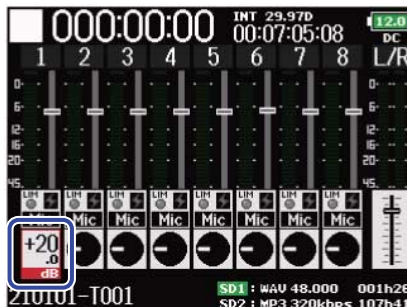

NOTE:

When a mic capsule is connected, the input levels of Input 1/2 cannot be adjusted with the F8n Pro. Use the level control on the mic capsule to adjust its input volume.

HINT:

- This can be set in a range from +10 to +75 dB when the input source is set to "Mic", from -10 to +55 dB when set to "Line", and from -35 to +30 dB when set to "USB". (→ [Setting the input source \(Input Source\)](#))
- If the sound distorts even when you lower the input level, try changing mic positions and adjusting the output levels of connected devices.
- Using the limiter (→ [Using the input limiter \(Input Limiter\)](#))
- Using the high pass filter (→ [Cutting low-frequency noise \(HPF\)](#))

Setting the sampling rate (Sample Rate)

You can set the sampling rate used to record files.

1. Press .

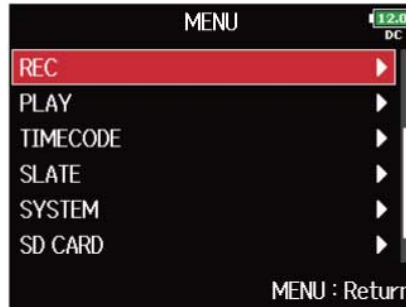

This opens the Menu Screen.

2. Use  to select "REC", and press .

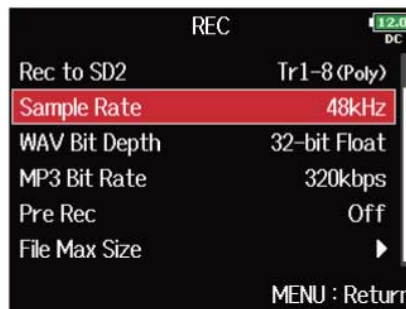

3. Use  to select "Sample Rate", and press .



4. Use  to select the sampling rate, and press .

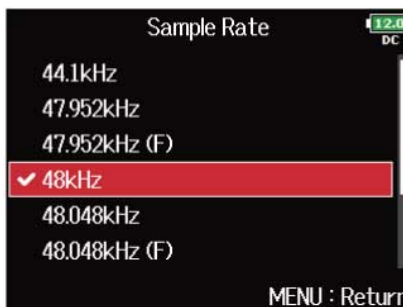

| Setting | Explanation |
|---|--|
| 44.1 kHz, 48 kHz, 88.2 kHz, 96 kHz, 192 kHz | These are standard sampling rates. |
| 47.952 kHz | Select this when recording video at 23.976 frames per second if you want to edit at 24 frames per second later. |
| 48.048 kHz | Select this when recording video at 24 frames per second if you want to edit at NTSC 29.97 or 23.98 HD later. |
| 47.952 kHz(F), 48.048 kHz(F) | These function the same as the two above, but the <FILE_SAMPLE_RATE> sampling rate metadata will be recorded as 48 kHz. This enables playback and editing with devices and software that do not support 47.952 kHz and 48.048 kHz WAV files. Playback, however, will occur at the $\pm 0.1\%$ speed at which the file was recorded. |

NOTE:



- When the recording file format is MP3, only 44.1 kHz and 48 kHz can be selected.
- When 192 kHz is selected, L/R tracks will not be recorded. "Input Delay" (→ [Delaying input signals \(Input Delay\)](#)) and "Output Delay" (→ [Delaying output signals \(Output Delay\)](#)) are also disabled. Moreover, "Auto Mix" (→ [Changing the automatic mixing setting \(Auto Mix\)](#)), "Ambisonic Mode" (→ [Setting the format of Ambisonic Mode](#)), and "Input Limiter" (→ [Using the input limiter \(Input Limiter\)](#)) cannot be set.
- "Audio Interface with Rec" cannot be used when values other than 44.1 kHz or 48 kHz are selected. (→ [Using SD card recording and audio interface functions at the same time \(Audio Interface with Rec\)](#))

Setting WAV file bit depth (WAV Bit Depth)

You can set the bit depth of WAV files.

1. Press .

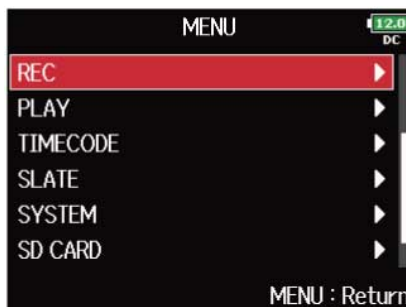

This opens the Menu Screen.

2. Use  to select "REC", and press .

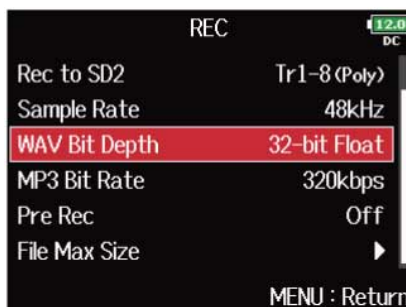

3. Use  to select "WAV Bit Depth", and press .



4. Use  to select the bit depth, and press .

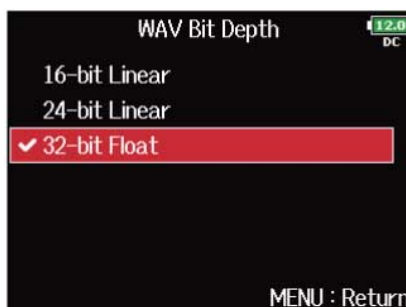

NOTE:

When "32-bit Float" is selected, "Exceeding maximum input level." will appear on the display if the input signal exceeds the maximum input level (+4 dB when the input source is set to "Mic" or +24 dB when the input source is set to "Line"). In this case, adjust the output level of the device connected to the input jack of the F8n Pro.

HINT:

This can be set to 16-bit Linear, 24-bit Linear or 32-bit Float.

Setting MP3 file bit rate (MP3 Bit Rate)

You can set the bit rate of recorded MP3 files.

1. Press .

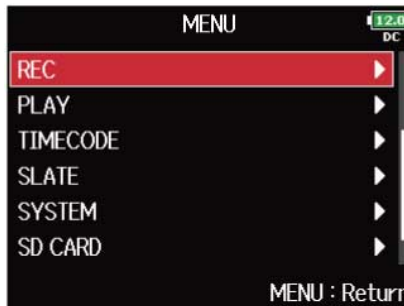

This opens the Menu Screen.

2. Use  to select "REC", and press .

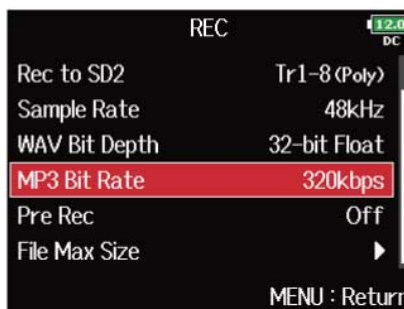

3. Use  to select "MP3 Bit Rate", and press .



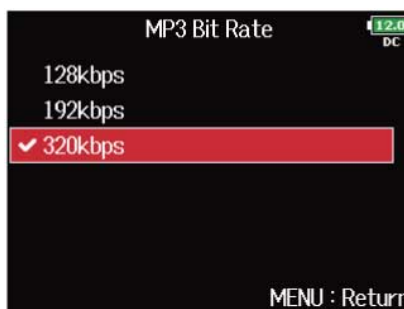

4. Use  to select the bit rate, and press .



HINT:



This can be set to 128 kbps, 192 kbps or 320 kbps.

Capturing audio before recording starts (Pre Rec)



The input signal can be captured for up to 6 seconds before  is pressed (pre-recording). This is useful if, for example,  is pressed too late.

1. Press .

This opens the Menu Screen.

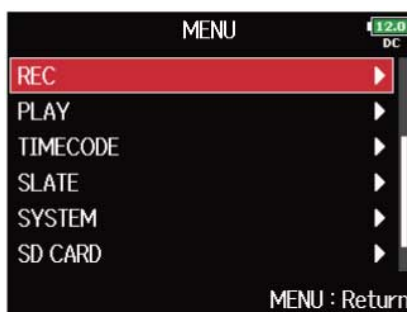
2. Use  to select "REC", and press .



3. Use  to select "Pre Rec", and press .

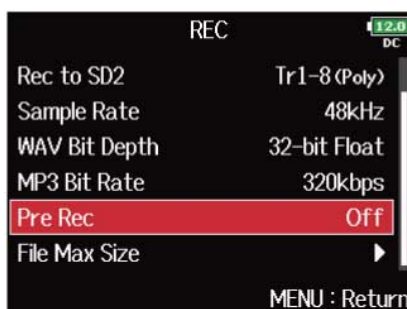

4. Use  to select "On", and press .



| | Sampling rate | Maximum pre-recording time |
|-----|---------------|----------------------------|
| WAV | 44.1 kHz | 6 seconds |
| | 47.952 kHz | 6 seconds |
| | 47.952 kHz(F) | 6 seconds |
| | 48 kHz | 6 seconds |
| | 48.048 kHz | 6 seconds |
| | 48.048 kHz(F) | 6 seconds |
| | 88.2 kHz | 3 seconds |
| | 96 kHz | 3 seconds |
| | 192 kHz | 1 seconds |
| MP3 | 44.1 kHz | 6 seconds |
| | 48 kHz | 6 seconds |

NOTE:



Pre-recording will be disabled if "Mode" is set to "Int Record Run", "Ext" or "Ext Auto Rec". (→ [Setting the mode](#))

Maximum file size (File Max Size)

The maximum size of recording files can be set. If a recording file exceeds the maximum file size, recording will continue in a new take with a number that is one higher.

1. Press .

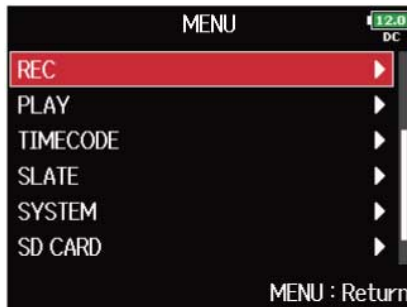

This opens the Menu Screen.

2. Use  to select "REC", and press .



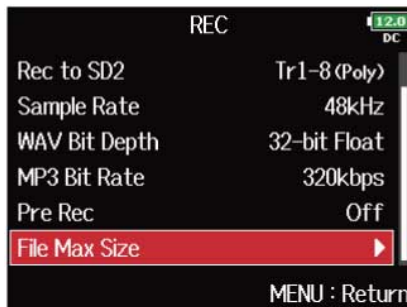

3. Use  to select "File Max Size", and press .

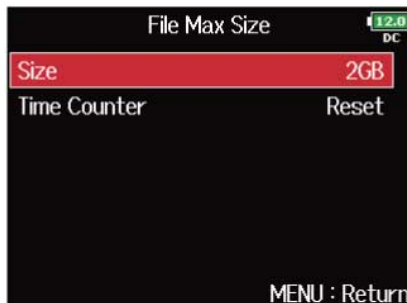

4. Use  to select "Size", and press .



5. Use  to select the maximum size of recording files, and press .

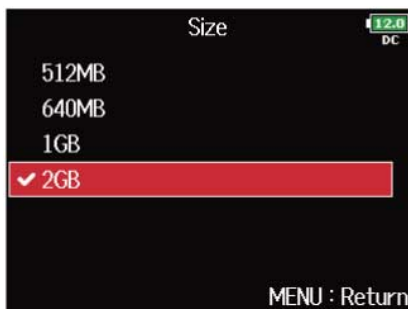

NOTE:

If a recording file exceeds the maximum file size, recording will continue in a new take with a number that is one higher. No gap will occur in the sound between the two takes when this happens.

HINT:



Setting the maximum size to 640 MB or 512 MB is convenient for backing up to CDs.

Showing total recording times for long recordings (Time Counter)

When recording for a long time, if the file size set with “[Maximum file size \(File Max Size\)](#)” is reached, recording will continue in a new take and the recording time will reset. You can change this, however, so that it is not reset and the total recording time is shown.

1. Press .

This opens the Menu Screen.

2. Use  to select “REC”, and press .

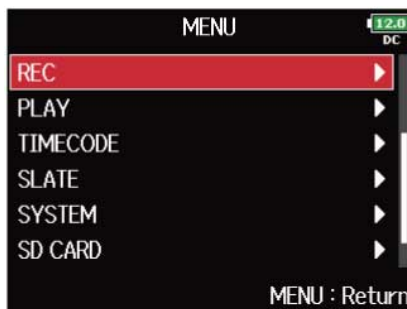

3. Use  to select “File Max Size”, and press .

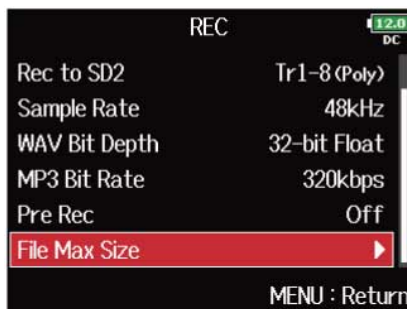

4. Use  to select “Time Counter”, and press .

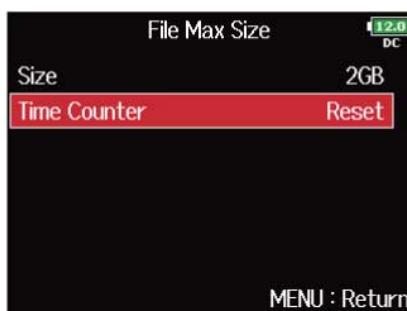

5. Use  to select "Continuous", and press .





| Setting | Explanation |
|------------|--|
| Continuous | When recording, even if the file size set with " Maximum file size (File Max Size) " is reached, the counter shown on the Home Screen will not be reset. |
| Reset | When recording, if the file size set with " Maximum file size (File Max Size) " is reached, the counter shown on the Home Screen will be reset to 000:00:00. |

Moving the previously recorded take to the FALSE TAKE folder

If the just recorded take was a failure, you can use a shortcut to move the recording to the FALSE TAKE folder.

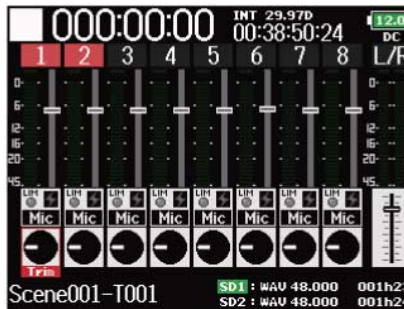

1. Open the Home Screen. (→ [Home Screen](#))



2. Press and hold .

HINT:

- Moving the take recorded most recently to the FALSE TAKE folder will reduce the number of the take recorded next by 1.
- Even during recording, you can move the previously recorded take to the FALSE TAKE folder.

3. Use  to select "Yes", and press .



Using timecode

Timecode overview

The F8n Pro can input and output SMPTE timecode.

Timecode is time information written to data when recording video and audio. It is used for video editing, control of other devices, and synchronization of audio and video.

■ Using timecode for editing

If video and audio data both have recorded timecode, aligning them to a timeline and synchronizing them together is easy when using nonlinear editing software for editing.

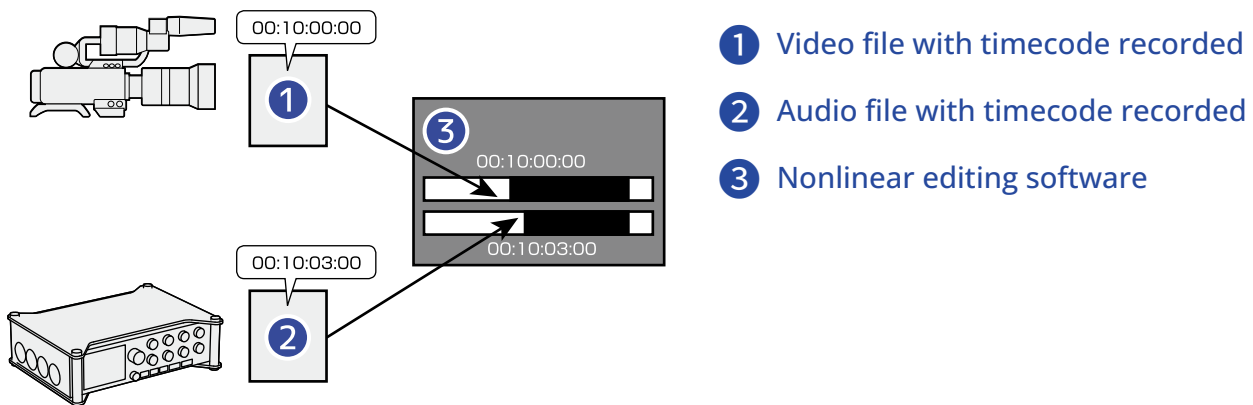

HINT:

The F8n Pro uses a precision oscillator that generates timecode with a high degree of accuracy (+/- 0.2 ppm, or approximately 0.5 frames per 24 hours).

■ Connection examples

Connections like the following are possible, depending upon the specific equipment being used with the F8n Pro.

Synchronizing with a video camera

The F8n Pro records with mic input and transmits timecode.

The F8n Pro saves the timecode that it generates with the audio data. The timecode received by the video camera is recorded with the video data.

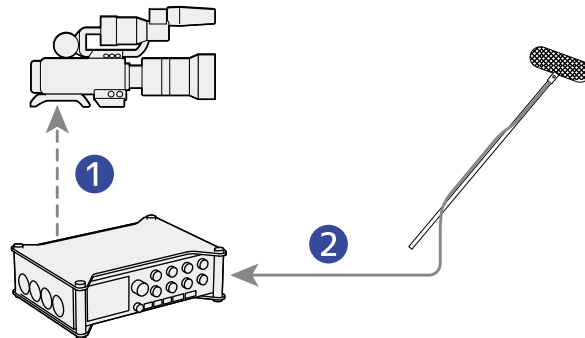

1 Timecode

2 Audio

Inputting timecode

Timecode is transmitted from an external timecode generator.

Both the F8n Pro and the video camera receive timecode and record it with their audio and video data.

The input timecode can also be used to synchronize the F8n Pro audio clock.

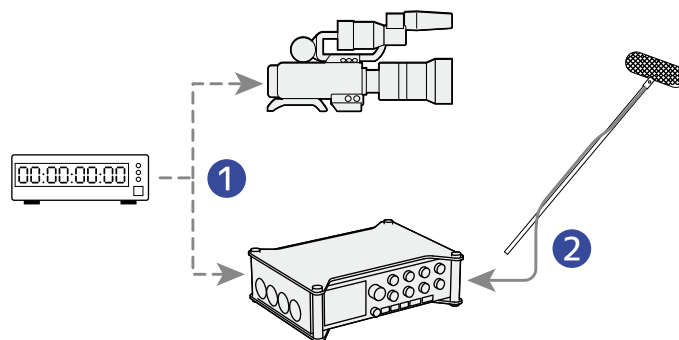

1 Timecode

2 Audio



Setting timecode functions

Use the timecode setting screen to set the timecode functions.



■ Opening the timecode setting screen

1. Press .

This opens the Menu Screen.

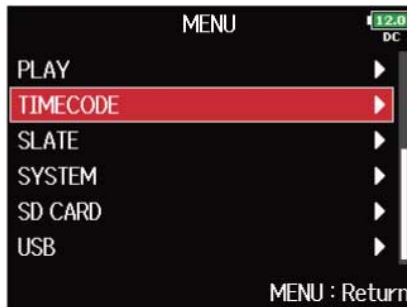
2. Use  to select "TIMECODE", and press .



3. Use  to select "Timecode", and press .

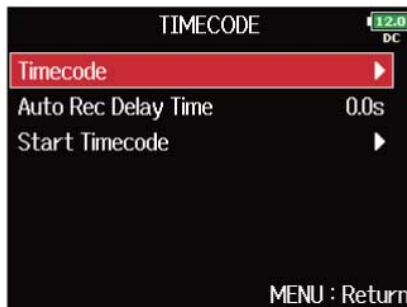

This opens the timecode setting screen.

For timecode setting details, see the links.

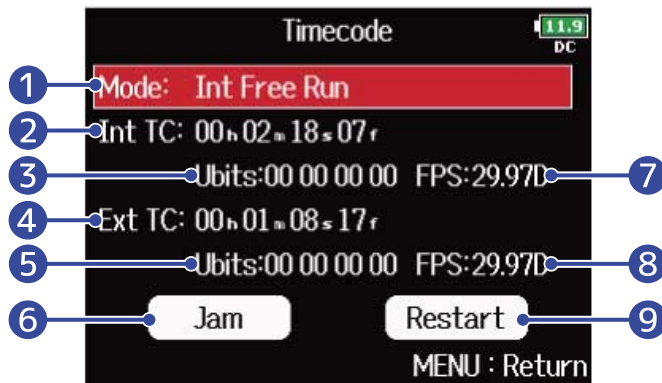

1 Timecode mode

Timecode mode settings, including on/off and transmission/receiving settings, can be made. (→ [Setting the mode](#))



- ② **Internal timecode**
This shows the internal timecode.
- ③ **Internal user bits**
This shows the User bit data that can be set to be included in the timecode. (→ [Setting the user bits for internal timecode](#))
- ④ **External timecode**
This shows the external timecode.
- ⑤ **External user bits**
This shows the external user bits.
- ⑥ **Jam button**
This uses timecode input through the TIMECODE IN jack to set the internal timecode. (→ [Jamming internal timecode](#))
- ⑦ **Internal timecode frame rate**
This shows the Internal timecode frame rate. (→ [Setting the frame rate for internal timecode](#))
- ⑧ **External timecode frame rate**
This shows the external timecode frame rate.
- ⑨ **Internal timecode restart button**
This restarts internal timecode with a specified value. (→ [Restarting internal timecode with a specified value](#))

■ Setting the mode



The timecode mode settings allow you to specify:

- Whether the F8n Pro generates timecode or receives external timecode
- Whether or not timecode continues running when not recording

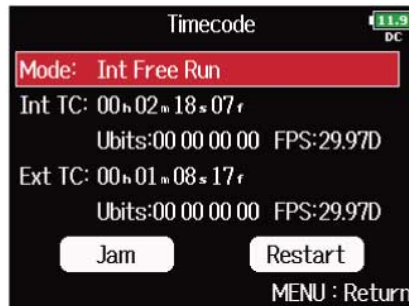

1. Open the timecode setting screen. (→ [Opening the timecode setting screen](#))

2. Use  to select "Mode", and press .

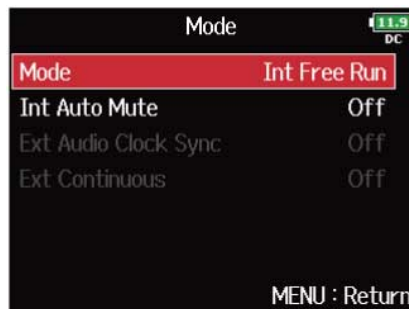

3. Use  to select "Mode", and press .



4. Use  to select the mode, and press .

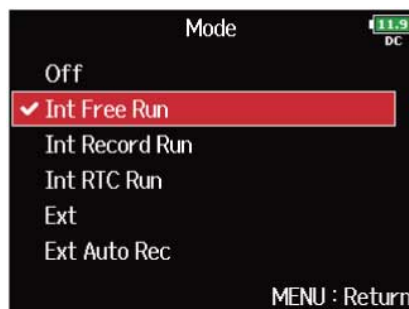



| Setting | Explanation |
|---------|---|
| Off | No timecode will be written to the recording file. Timecode will not be output from the TIMECODE OUT jack. |

| Setting | Explanation |
|----------------|--|
| Int Free Run | <p>Internal timecode will be generated regardless of the recording mode.</p> <p>The internal timecode can be set manually using the following operations:</p> <ul style="list-style-type: none"> • Jamming internal timecode • Restarting internal timecode with a specified value <p>Timecode will always be output from the TIMECODE OUT jack.</p> |
| Int Record Run | <p>Internal timecode will be generated only when recording.</p> <p>The internal timecode can be set manually using the following operations:</p> <ul style="list-style-type: none"> • Jamming internal timecode • Restarting internal timecode with a specified value <p>When switching from another mode, or when recording stops, the internal timecode will stop at the last value.</p> |
| Int RTC Run | <p>Internal timecode will be generated regardless of the recording mode.</p> <p>In the following situations, the internal timecode will be synchronized (jammed) with the RTC (internal clock):</p> <ul style="list-style-type: none"> • At startup • When "Date/Time (RTC)" has changed (→ Setting the date and time (Date/Time (RTC))) • When switching to this timecode mode <p>Timecode will always be output from the TIMECODE OUT jack.</p> |
| Ext | <p>The internal timecode will chase the external timecode.</p> <p>You can also enable the automatic generation of internal timecode when there is no external timecode. (→ Automatically enabling internal timecode when no external timecode is input)</p> |
| Ext Auto Rec | <p>The internal timecode will chase the external timecode.</p> <p>You can also enable the automatic generation of internal timecode when there is no external timecode. (→ Automatically enabling internal timecode when no external timecode is input)</p> <p>Recording starts automatically when external timecode input is detected. Recording stops automatically when external timecode stops.</p> |

■ Stopping timecode output when recording is stopped

You can set whether or not timecode is output from the TIMECODE OUT jack when recording is stopped.

1. Open the timecode setting screen. (→ [Opening the timecode setting screen](#))

2. Use  to select "Mode", and press .

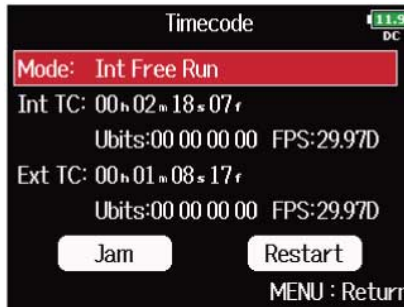

3. Use  to select "Int Auto Mute", and press .

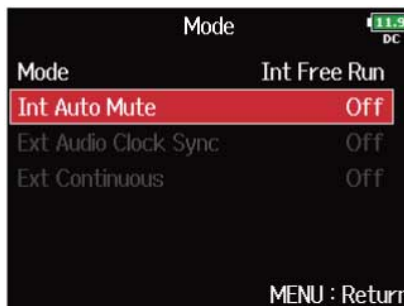

4. Use  to select "On", and press .

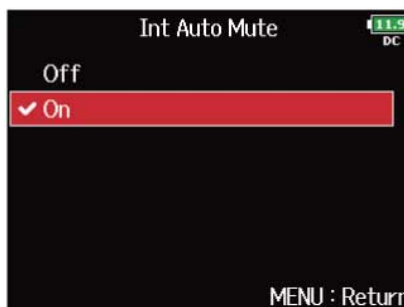



NOTE:

- Timecode will continue to be output when recording/playback is paused.
- This cannot be set when "Mode" is set to "Off", "Int Record Run", "Ext" or "Ext Auto Rec". (→ [Setting the mode](#))

■ Synchronizing audio clock with external timecode

1. Open the timecode setting screen. (→ [Opening the timecode setting screen](#))

2. Use  to select "Mode", and press .

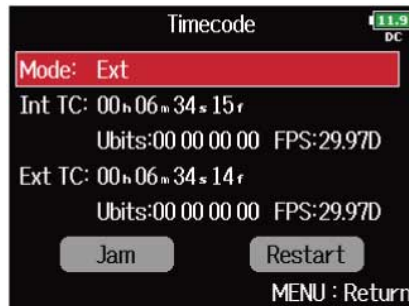

3. Use  to select "Ext Audio Clock Sync", and press .

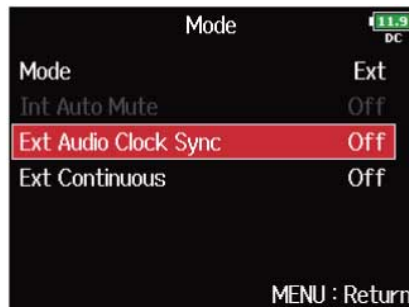

4. Use  to select "On", and press .

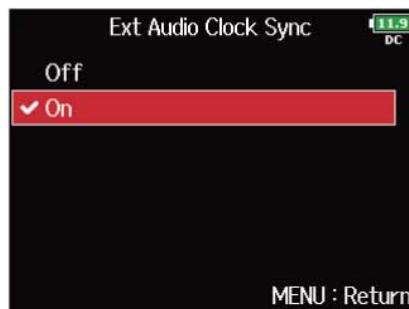

NOTE:

- When there is no external timecode, the internal audio clock is enabled to preserve continuity.
- This cannot be set when "Mode" is set to "Off", "Int Free Run", "Int Record Run" or "Int RTC Run". (→ [Setting the mode](#))

■ Automatically enabling internal timecode when no external timecode is input

You can enable the automatic generation of internal timecode to preserve continuity when there is no external timecode.

1. Open the timecode setting screen. (→ [Opening the timecode setting screen](#))

2. Use  to select "Mode", and press .

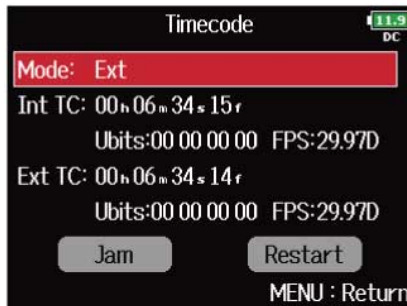

3. Use  to select "Ext Continuous", and press .

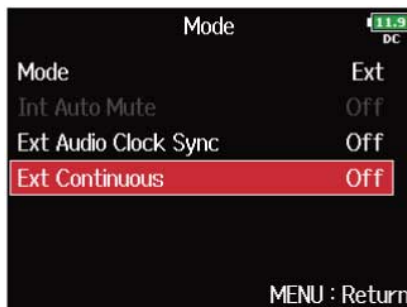

4. Use  to select "On", and press .



NOTE:



This cannot be set when "Mode" is set to "Off", "Int Free Run", "Int Record Run" or "Int RTC Run". (→ [Setting the mode](#))

■ Setting the user bits for internal timecode

User bits are data that you can set to be included in the timecode. Up to 8 numbers (0-9) and letters (A-F) can be included. Recording date information, for example, can be useful when editing later.

Setting the user bits (Ubits) mode



1. Open the timecode setting screen. (→ [Opening the timecode setting screen](#))

2. Use  to select "Ubits", and press .

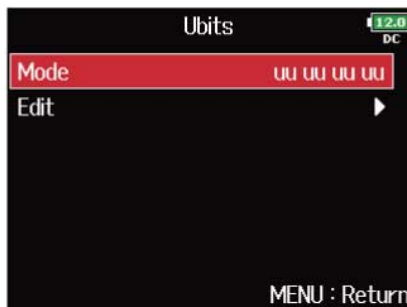

3. Use  to select "Mode", and press .



4. Use  to select the mode, and press .





| Setting | Explanation |
|-------------|--|
| uu uu uu uu | You can set these values as you like on the "Edit" screen. |
| mm dd yy uu | The month, day and year are entered automatically in that order using the RTC setting. You can set the "uu" value as you like on the "Edit" screen. |
| dd mm yy uu | The, day, month and year are entered automatically in that order using the RTC setting. You can set the "uu" value as you like on the "Edit" screen. |
| yy mm dd uu | The year, month and day are entered automatically in that order using the RTC setting. You can set the "uu" value as you like on the "Edit" screen. |

HINT:



Only "uu" items can be changed.

Setting user bits (Ubits)

1. Open the timecode setting screen. (→ [Opening the timecode setting screen](#))

2. Use  to select "Ubits", and press .



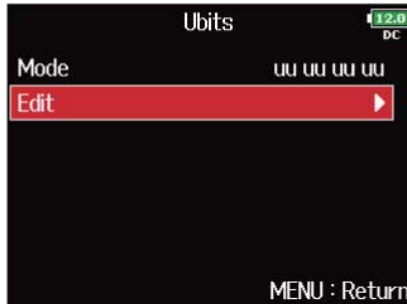

3. Use  to select "Edit", and press .



4. Edit the value.

■ Editing operations

Move cursor or change value: Turn .

Select parameter to change: Press .



HINT:

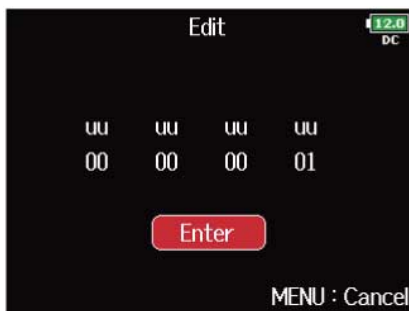

User bits can only consist of numbers from 0 to 9 and letters from A to F.

5. When done changing the setting, use  to select "Enter", and press .





■ Setting the frame rate for internal timecode

1. Open the timecode setting screen. (→ [Opening the timecode setting screen](#))

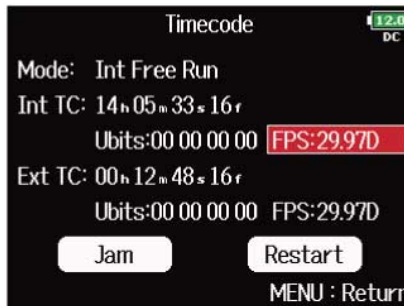
2. Use  to select "FPS", and press .



3. Use  to select the frame rate, and press .

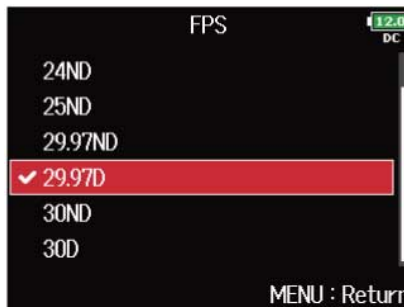

| Setting | Explanation |
|----------|---|
| 23.976ND | This is the most common frame rate used with HD cameras and other high-definition video recording. The count is 0.1% slower than the actual time. |
| 24ND | This is the standard frame rate used for recording film. This is also used with HD cameras. |
| 25ND | This is the frame rate for PAL video. This is used for PAL video, which is used in Europe and other regions. |
| 29.97ND | This is a frame rate used for NTSC color video and HD cameras. The count is 0.1% slower than the actual time. This is used for NTSC video, which is used in Japan, the United States and other countries. |
| 29.97D | This is an adjusted frame rate that uses drop frames to make NTSC match the actual time. This is used with video for broadcast that requires the actual time frame to be matched. |
| 30ND | This is used to synchronize sound with film that is being transferred to NTSC video. This is the standard frame rate used for black-and-white television in Japan, the United States and other countries. |

| Setting | Explanation |
|---------|---|
| 30D | This rate is used for special applications. This synchronizes with film sound to be transferred to NTSC using 29.97fps drop frame. The count is 0.1% faster than the actual time. |



NOTE:

Matching frame rates must be set in advance on all connected video and audio devices.

■ Jamming internal timecode

Timecode input through the TIMECODE IN jack is used to set internal timecode.

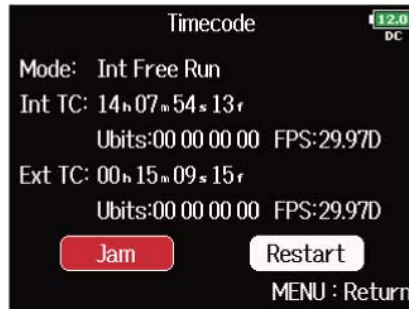

1. Open the timecode setting screen. (→ [Opening the timecode setting screen](#))

2. Use  to select "Jam", and press .



Restarting internal timecode with a specified value

1. Open the timecode setting screen. (→ [Opening the timecode setting screen](#))

2. Use  to select "Restart", and press .





3. Set the restart value.

Editing operations

Move cursor or change value: Turn .

Select parameter to change: Press .



4. Use  to select "Restart", and press .





Setting automatic timecode recording delay (Auto Rec Delay Time)

If set to record automatically when external timecode is received, unnecessary recording could occur when timecode is received for a brief amount of time. In order to prevent this, you can set the amount of time until recording starts after timecode is received.

1. Press .

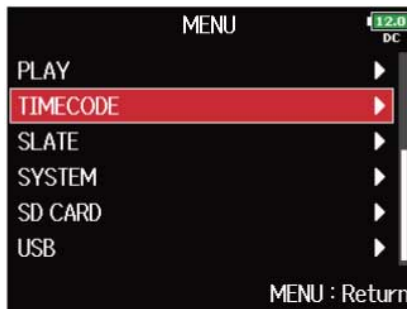

This opens the Menu Screen.

2. Use  to select "TIMECODE", and press .

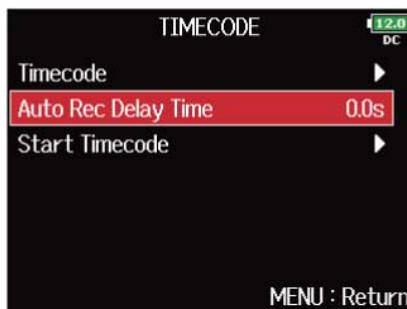

3. Use  to select "Auto Rec Delay Time", and press .



4. Use  to adjust the time, and press .

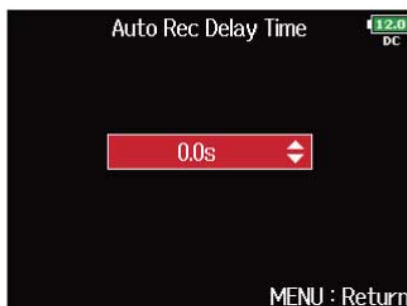

HINT:

This can be set from 0.0 to 8.0 s.

Setting timecode initialization used at startup (Start Timecode)

Since internal timecode stops when the F8n Pro is turned off, the timecode is automatically initialized (jammed) during startup. You can set the value that is used for jamming at that time.

■ Setting how timecode is initialized at startup

1. Press .

This opens the Menu Screen.

2. Use  to select "TIMECODE", and press .

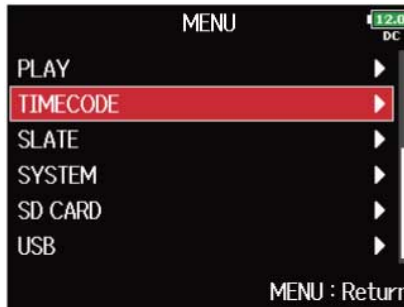

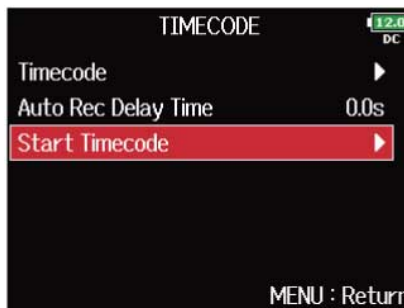

3. Use  to select "Start Timecode", and press .

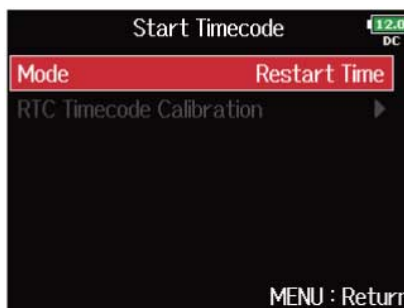

4. Use  to select "Mode", and press .



5. Use  to set how timecode is initialized, and press .

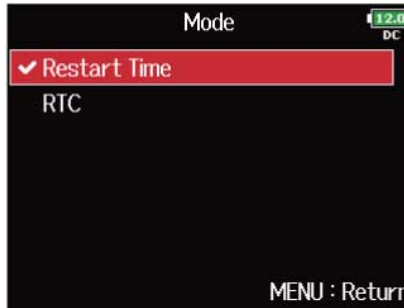

| Setting | Explanation |
|--------------|---|
| Restart Time | When the F8n Pro starts, the value set by "Restart" is used to jam the internal timecode. (→ Restarting internal timecode with a specified value) |
| RTC | When the F8n Pro starts, its timecode is restored from the timecode when the power was turned off and advanced by the elapsed time using the "Date/Time (RTC)" setting (→ Setting the date and time (Date/Time (RTC))). Since RTC is less precise than internal timecode, discrepancies will occur. |

■ Correcting timecode errors after the power has been turned off

When “Mode” of “Start Timecode” is set to “RTC”, turning the power off lowers the timecode precision, but this function can improve the error to the value close to 0.2 ppm when the power has been turned off.

1. Press .

This opens the Menu Screen.

2. Use  to select “TIMECODE”, and press .

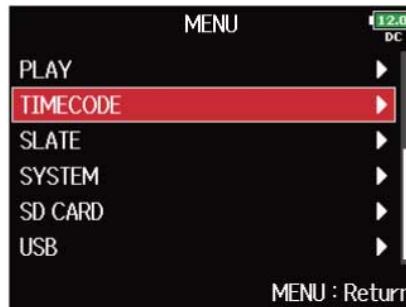

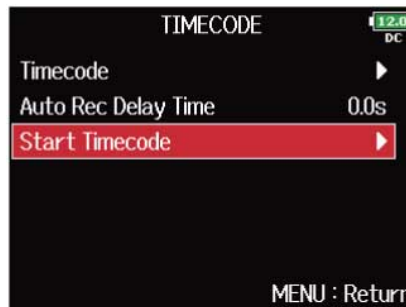

3. Use  to select “Start Timecode”, and press .



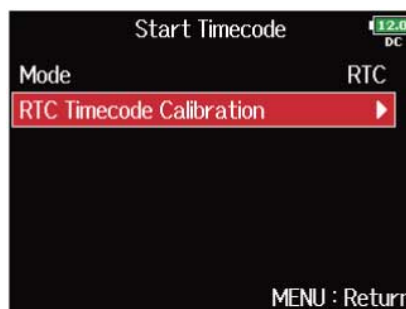

4. Use  to select “RTC Timecode Calibration”, and press .

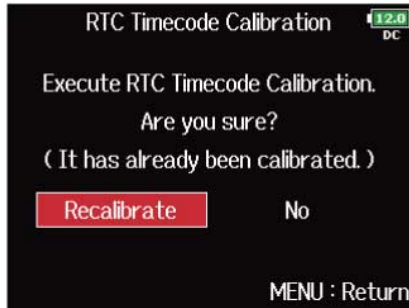

5. Use  to select "Recalibrate", and press .



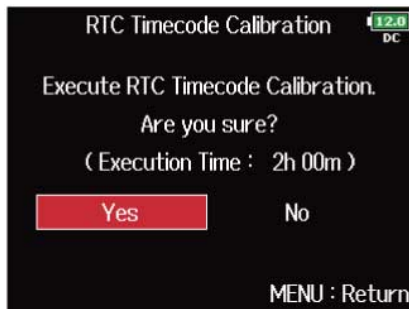

6. Use  to select "Yes", and press .

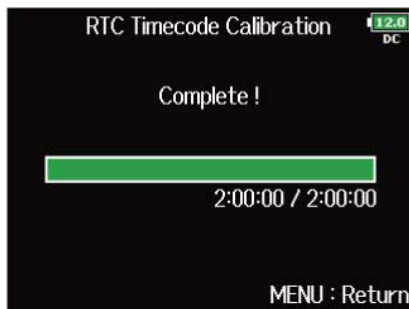

7. Calibration completes.



8. To cancel calibration, press MENU, and use  to select "Yes", and press .

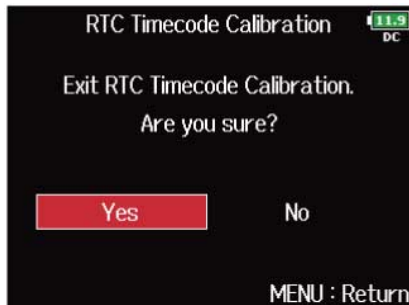

NOTE:

- The F8n Pro is calibrated before being shipped new from the factory.
- After calibrating once, the result will be retained.
- If the F8n Pro is moved to and used in an extremely hot or cold location, timecode precision could change slightly when the power is turned off. In such cases, we recommend calibrating it again.
- Calibration is not possible when "Audio Interface with Rec" is set to "On". (→ [Using SD card recording and audio interface functions at the same time \(Audio Interface with Rec\)](#))
- Calibration is only possible when "Mode" of "Start Timecode" is set to "RTC".
- Calibration is not possible when an FRC-8 is connected. (→ [Using the FRC-8](#))

Using with an UltraSync BLUE



The F8n Pro can receive timecode from a connected UltraSync BLUE and record it in audio recording files.

- This function cannot be used with an F8n Pro after it is first shipped from the factory. To use this function, a software extension file must be downloaded from the ZOOM website (zoomcorp.com) and installed in the unit.
- The F8n Pro has received radio law certification in Japan, the USA, Canada and Europe (EU). Use of this function is not allowed in other countries and regions. Using it in countries where certification has not been received could result in legal penalties. ZOOM CORPORATION will not assume any responsibility related to penalties due to the use of this function.



■ Connecting with an UltraSync BLUE

Connect the F8n Pro and an UltraSync BLUE.

1. Press and hold  on the Home Screen.

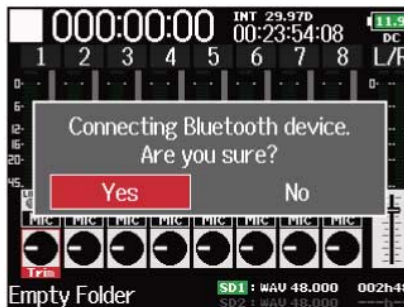
2. Use  to select "Yes", and press .



3. Use  to select "Timecode", and press .

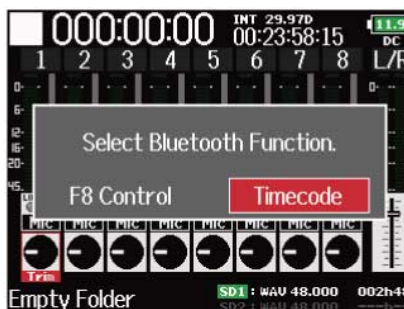

Searching for the connected device will begin and "Searching..." will appear on the display.

HINT:

- Searching can be canceled by pressing .
- You can restart searching by selecting "Pair" on the "Timecode" screen even if searching has been canceled.

4. On the UltraSync BLUE, select the F8n Pro as the connected device.

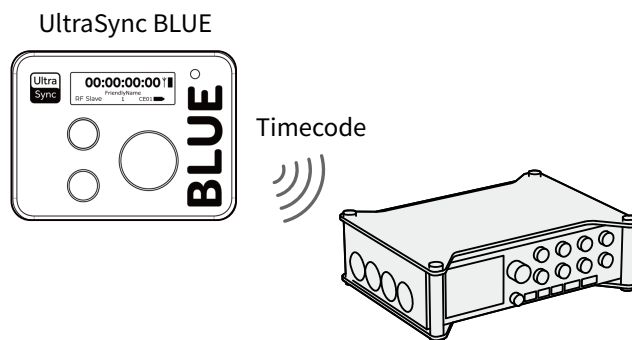

When pairing completes, "Connected." will appear on the F8n Pro display.



HINT:

- See the UltraSync BLUE manual for the procedures to select connected devices.
- Use the F8n Pro and the UltraSync BLUE as close together as possible to make communication more reliable.
- If communication with the UltraSync BLUE is interrupted during recording, timecode data from the F8n Pro will be added to the recording file.

■ Disconnecting from an UltraSync BLUE

A connected UltraSync BLUE can be disconnected from the F8n Pro, stopping timecode recording. Pairing information will be retained even when disconnected.

1. Press and hold  on the Home Screen.

2. Use  to select "Yes", and press .

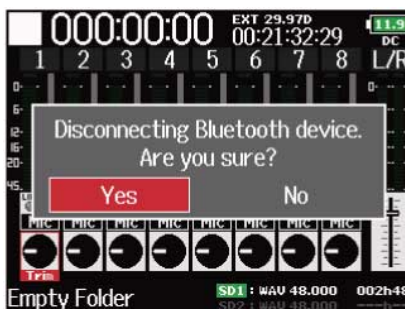

This disconnects the UltraSync BLUE. "Disconnected." will appear on the display.

■ Connecting with a different UltraSync BLUE



To receive timecode from a different UltraSync BLUE, the pairing of the currently registered one must be first canceled and then the new one must be paired.

1. Press .

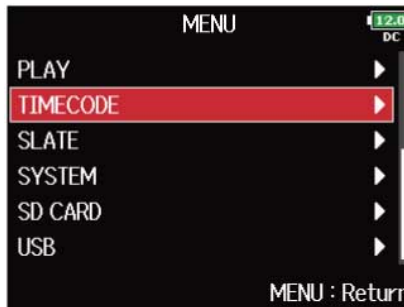

This opens the Menu Screen.

2. Use  to select "TIMECODE", and press .



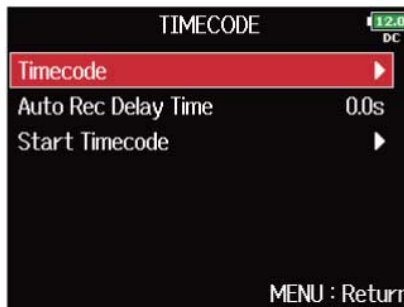

3. Use  to select "Timecode", and press .



4. Use  to select "Forget", and press .



5. Use  to select "Pair", and press .

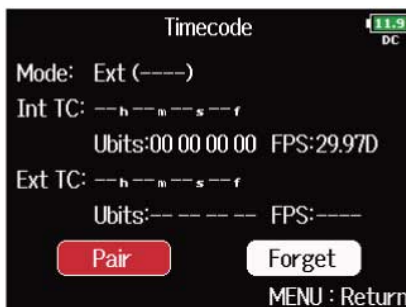

Searching for the connected device will begin and "Searching..." will appear on the display.

HINT:

- Searching can be canceled by pressing .
- You can restart searching by selecting "Pair" on the "Timecode" screen if searching has been canceled.

6. On the new UltraSync BLUE, select the F8n Pro as the device to connect.
When pairing completes, "Connected." will appear on the F8n Pro display.

HINT:

- See the UltraSync BLUE manual for the procedures to select connected devices.
 - Use the F8n Pro and the UltraSync BLUE as close together as possible to make communication more reliable.
 - If communication with the UltraSync BLUE is interrupted during recording, timecode data from the F8n Pro will be added to the recording file.
-

Setting the recording take

Changing the note for the next take recorded (Note)



You can input characters for a note to use as metadata in the file.

1. Press .

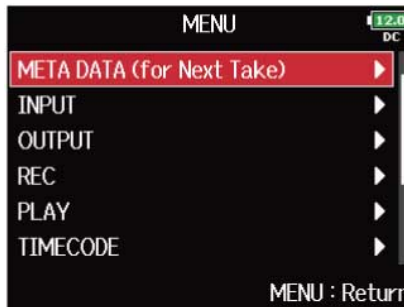

This opens the Menu Screen.

2. Use  to select "META DATA (for Next Take)", and press .

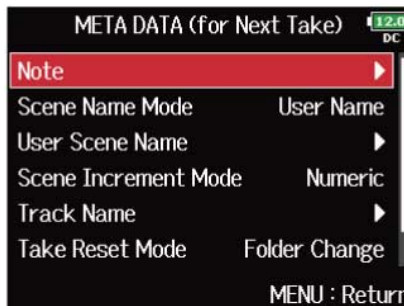

3. Use  to select "Note", and press .



4. Use  to select "Edit", and press .

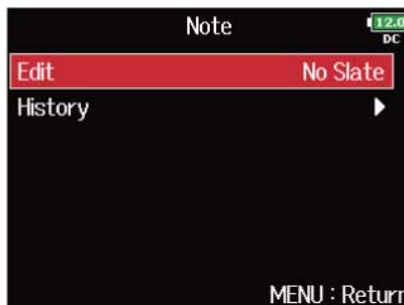

5. Edit the note.

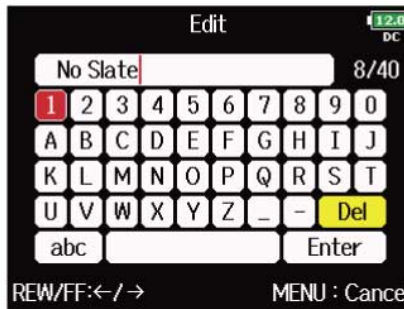



See "[Character input screen](#)" for how to input characters.

NOTE:



This note is written to the <NOTE> metadata.

HINT:

You can select notes from the history list.

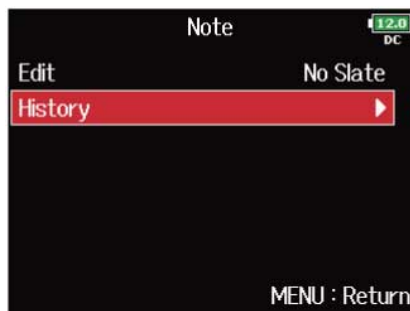
1. Use  to select "History", and press  in step 4.



2. Use  to select the item to use, and press .



The history list will be erased if the "Factory Reset" function is used. (→ [Restoring factory default settings](#))

Setting how recorded scenes are named and numbered

You can set how scenes are named (name mode), the base scene name and how scene numbers advance.



■ Setting how scenes are named (mode)

1. Press .

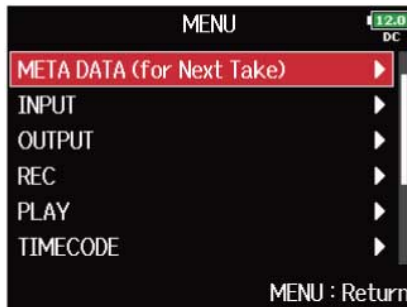

This opens the Menu Screen.

2. Use  to select "META DATA (for Next Take)", and press .



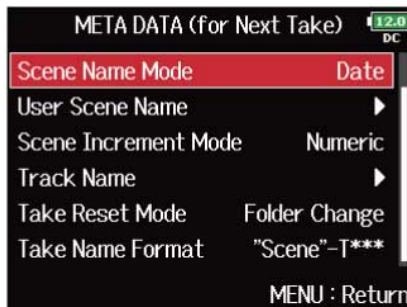





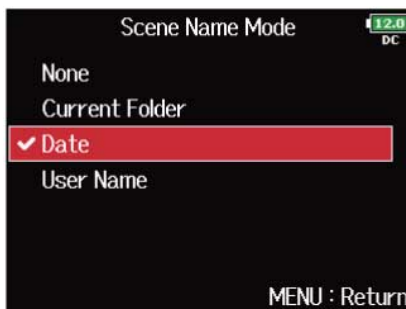

3. Use  to select "Scene Name Mode", and press .



4. Use  to select the mode, and press .





| Setting | Explanation |
|----------------|---|
| None | <p>The scene name and number are not used. When recording files are created, they are named only with the take number, such as "T001", "T002", "T003" and so on.  +  cannot be used to advance the scene number by 1. Example: T001.wav</p> |
| Current Folder | <p>The name of the currently selected folder is used as the scene name.  +  can be used to advance the scene number by 1. After advancing the scene number by 1, the corresponding folder will be used as the recording destination. If that folder does not already exist, it will be created. Example: FOLDER001-T001.wav</p> |
| Date | <p>The date is used as the scene name.  +  cannot be used to advance the scene number by 1. If recording occurs after the date changes, a scene folder with the date will be created. Example: 20210101-T001.wav</p> |
| User Name | <p>A scene name input by the user is used.  +  can be used to advance the scene number by 1. No folder is created in this case. Example: MYSCENE001-T001.wav</p> |

■ Changing scene names

If "Scene Name Mode" is set to "User Name", set the scene name used like this.

1. Press .

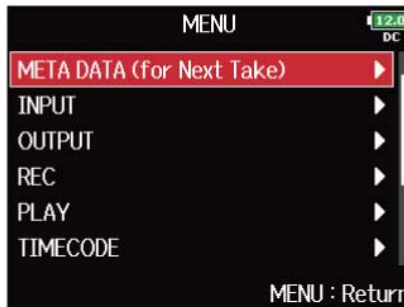

This opens the Menu Screen.

2. Use  to select "META DATA (for Next Take)", and press .

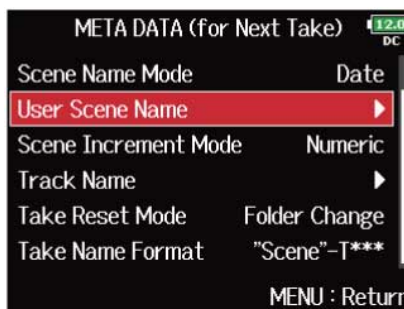

3. Use  to select "User Scene Name", and press .



4. Use  to select "Edit", and press .

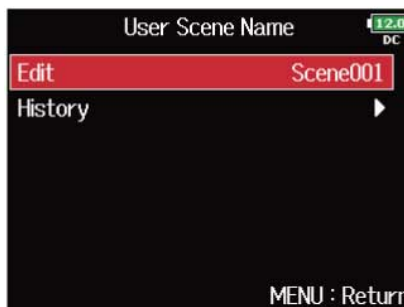

5. Edit the scene name.



See "[Character input screen](#)" for how to input characters.



NOTE:

The scene name is written to the <SCENE> metadata.



You cannot put a space or an @ mark at the beginning of the name.

HINT:

You can select a scene name from the history list.

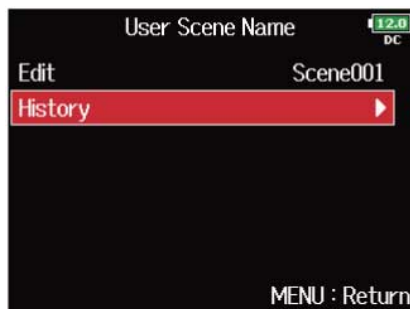
1. Use  to select "History", and press  in step 4.



2. Use  to select the item to use, and press .





The history list will be erased if the "Factory Reset" function is used. (→ [Restoring factory default settings](#))



■ Setting how scene numbers advance

1. Press .

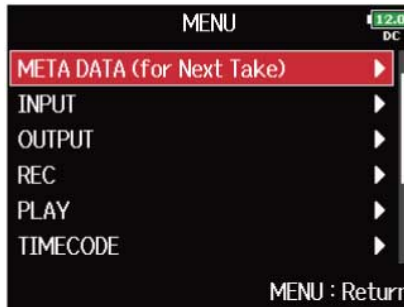

This opens the Menu Screen.

2. Use  to select "META DATA (for Next Take)", and press .



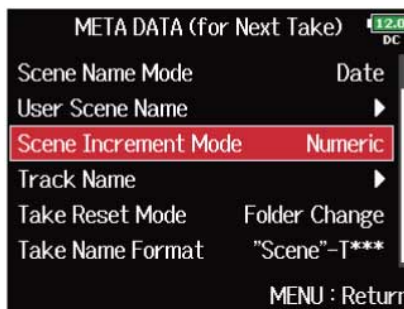



3. Use  to select "Scene Increment Mode", and press .

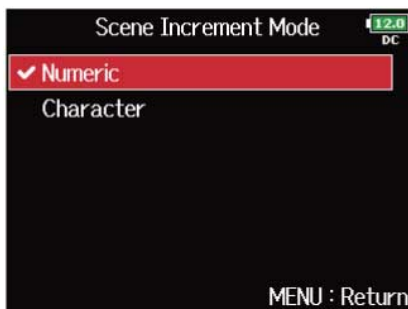

4. Use  to select how scene numbers advance, and press .



| Setting | Explanation |
|-----------|---|
| Numeric | Press  +  on the Home Screen to increase the scene number by one. Example: Scene → Scene1 → Scene2 → ... → Scene9999 |
| Character | Press  +  on the Home Screen to advance the capital letter at the end of the scene name by one. If the scene name does not have a capital letter at its end, one will be added. Example: Scene1 → Scene1A → Scene1B → ... → Scene1Z → Scene1AA → Scene1AB → ... |



Setting the take name reset condition and format

You can set the take name reset condition and format used when recording.



■ Setting the take name reset condition

1. Press .

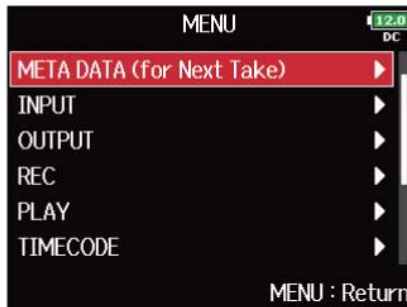

This opens the Menu Screen.

2. Use  to select "META DATA (for Next Take)", and press .

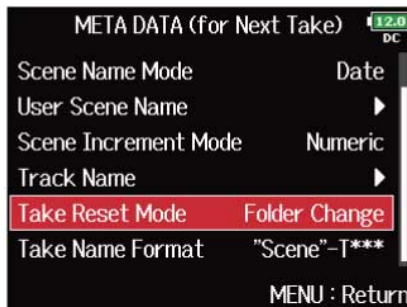

3. Use  to select "Take Reset Mode", and press .



4. Use  to select the reset mode, and press .

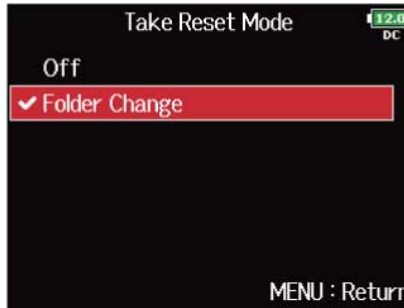

| Setting | Explanation |
|---------------|---|
| Off | The take number will not be reset. However, if the folder is changed and that folder contains a number higher than the current take number, the take number will be set to one higher than the highest existing take number. |
| Folder Change | If the destination folder is changed, the take number will be set to one higher than the highest take number in that folder. |



■ Setting the take name format

1. Press .

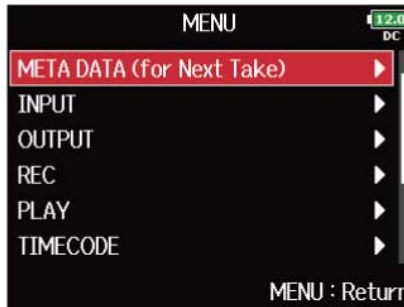

This opens the Menu Screen.

2. Use  to select "META DATA (for Next Take)", and press .

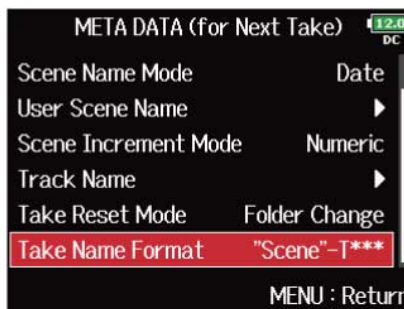

3. Use  to select "Take Name Format", and press .



4. Use  to select the format, and press .



| Setting | Explanation |
|--------------|---|
| "Scene"-T*** | <div style="display: flex; align-items: center; gap: 20px;"> <div style="text-align: center;"> <u>"Scene"</u> ① </div> <div style="text-align: center;"> <u>-T***</u> ② </div> </div> <p>①: Scene name ②: Track name Example: Scene001-T001</p> |
| "Scene"_*** | <div style="display: flex; align-items: center; gap: 20px;"> <div style="text-align: center;"> <u>"Scene"</u> ① </div> <div style="text-align: center;"> <u>_***</u> ② </div> </div> <p>①: Scene name ②: Track name Example: Scene001_001</p> |

Changing the track name of the next take recorded (Track Name)



The track name set with the following procedure will be given to the next recorded track.

1. Press .

This opens the Menu Screen.

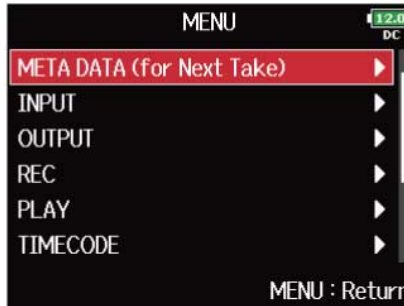

2. Use  to select "META DATA (for Next Take)", and press .



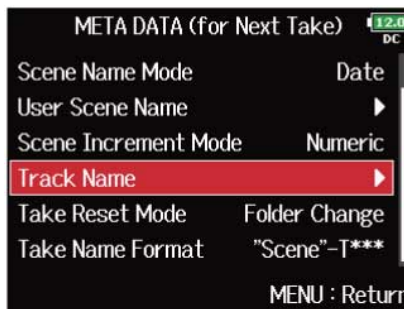

3. Use  to select "Track Name", and press .





HINT:

On the Home Screen,  +  can be used to open the "Track Name" screen.

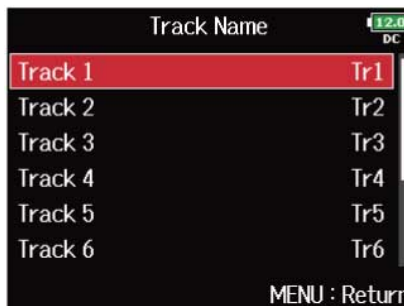
4. Use  to select a track, and press .



5. Use  to select "Edit", and press .



6. Edit the track name.

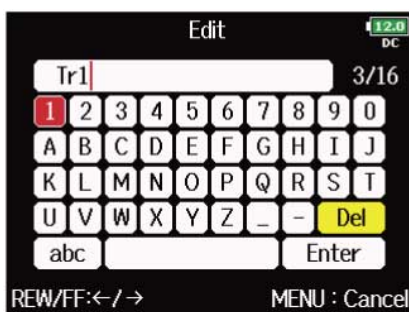



See "[Character input screen](#)" for how to input characters.

NOTE:



The track name is written to the <TRACK> <NAME> metadata.

HINT:

You can select a track name from the history list.

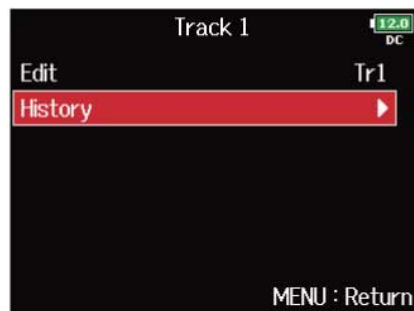
1. Use  to select "History", and press  in step 5.



2. Use  to select the item to use, and press .

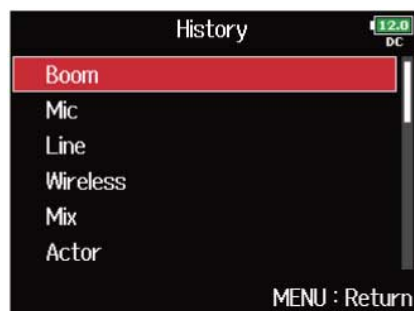



The history list will be erased if the "Factory Reset" function is used. (→ [Restoring factory default settings](#))

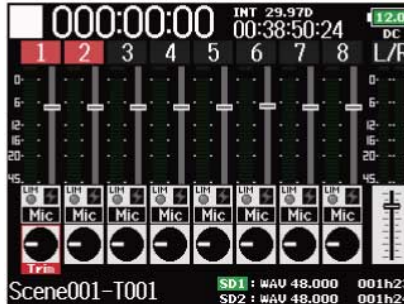

Changing the number of the next take recorded

The number given to the next recorded take can be changed when the Home Screen is open.

1. Open the Home Screen. (→ [Home Screen](#))



2. Press and hold .

3. Use  to increase or decrease the take number by one, and press .



NOTE:

This function cannot be used during recording and playback or when the "Scene Name Mode" (scene naming method) is set to "Date". You can change how scenes are named with [Setting how scenes are named \(mode\)](#).

Using the slate mic and slate tone

Slate mic and slate tone overview

When recording with the F8n Pro, you can add audio comments that describe, for example, the scene being filmed or the anticipated cuts. You can also record slate tone signals that can be used to synchronize with video.

The F8n Pro has a built-in slate mic for recording comments and the ability to output a variable frequency tone signal.

NOTE:

- The slate mic and slate tone cannot be used at the same time.
- The slate mic and slate tone cannot be used during audio file playback.

HINT:

A "slate" is a clapperboard used when recording video.

Recording with the slate mic (Slate Mic)

You can use the built-in slate mic to record comments and to keep notes about recorded takes.



■ Setting the volume

1. Press .

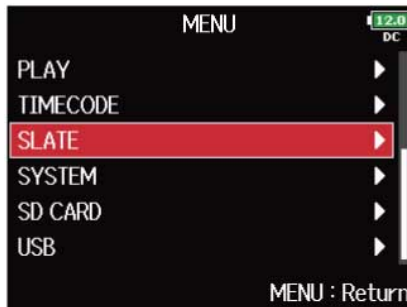

This opens the Menu Screen.

2. Use  to select "SLATE", and press .





3. Use  to select "Slate Mic", and press .

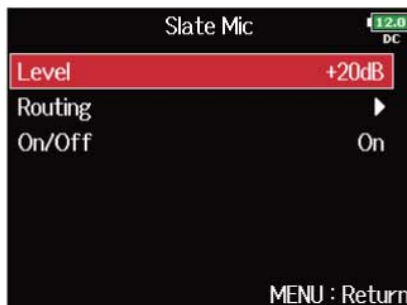

4. Use  to select "Level", and press .



5. Use  to adjust the level, and press  .



HINT:

This can be set from 0 to 24 dB.

■ Setting the routing



Set the destination for the slate mic signal.

1. Press .

This opens the Menu Screen.

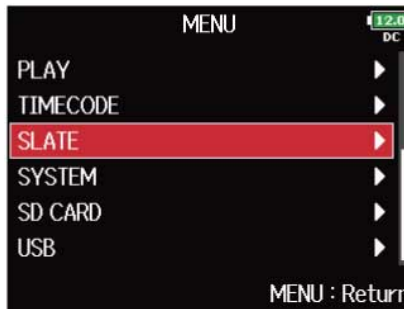
2. Use  to select "SLATE", and press .





3. Use  to select "Slate Mic", and press .

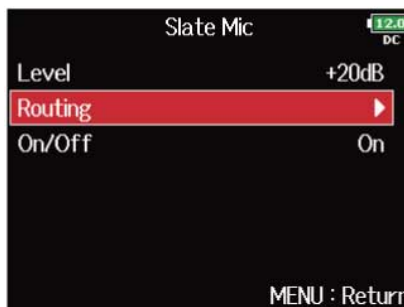

4. Use  to select "Routing", and press .



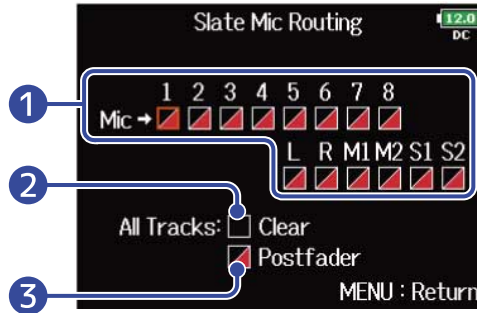

5. Use  to select the tracks/outputs for slate mic signal routing, and press .



1 Tracks/outputs for slate mic signal routing

Press  to switch between "Postfader" and "Off".

- : Postfader selected
- : Off

2 All Clear

This clears all settings.

3 Postfader setting

This sets all tracks to postfader.

NOTE:

Routing to tracks 1-8 is not possible when operating the F8n Pro as an audio interface (Stereo Mix). (→ [Using as an audio interface \(Audio Interface\)](#))

6. Press .

■ Recording

1. Press  to start recording.

2. Push  left toward the mic symbol and release.

3. To disable the slate mic, push  left toward the mic symbol again and release.

NOTE:

- When the slate mic is in use, other signals input to the tracks that it is routed to are muted.
- The slate mic signal is always routed to the headphone L/R channels regardless of other routing settings.
- The MAIN OUT 1/2 and SUB OUT 1/2 faders do not affect the levels of the slate mic and slate tone.

HINT:



If you push and hold  left toward the mic symbol for two or more seconds, the slate mic will be enabled until you release the switch.

■ Disabling the slate mic



You can set the slate mic so that it will not be enabled if  is accidentally pushed left toward the mic symbol.

1. Press .

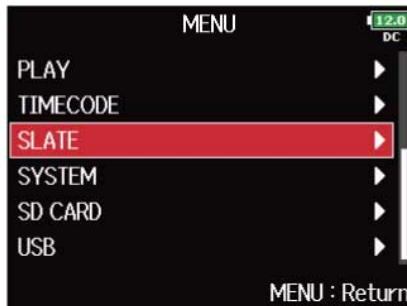

This opens the Menu Screen.

2. Use  to select "SLATE", and press .





3. Use  to select "Slate Mic", and press .

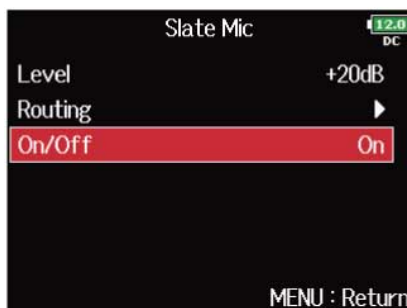

4. Use  to select "On/Off", and press .



5. Use  to select "Off (Lock)", and press .

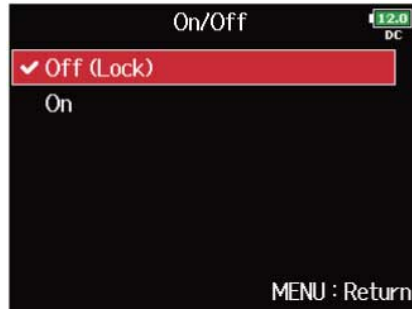

Recording a slate tone (Slate Tone)

By adding a slate tone when the recording starts, aligning audio to video during editing will be easier. You can also use a slate tone to coordinate levels with connected equipment.



■ Setting the volume

1. Press .

This opens the Menu Screen.

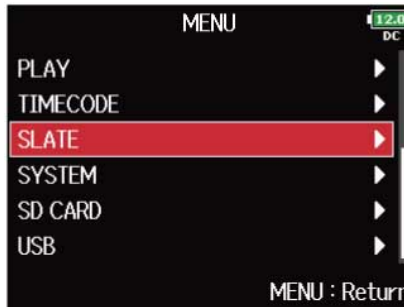
2. Use  to select "SLATE", and press .



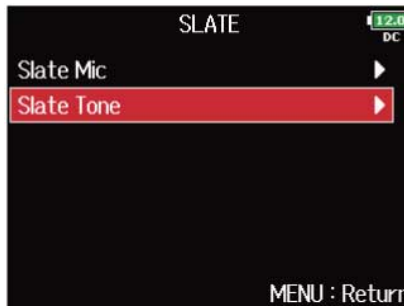

3. Use  to select "Slate Tone", and press .

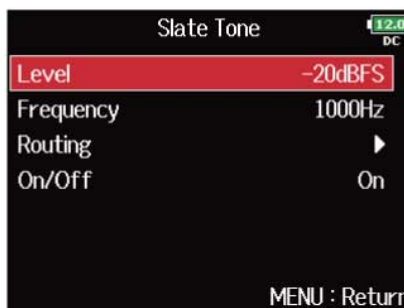

4. Use  to select "Level", and press .



5. Use  to adjust the level, and press  .



HINT:

This can be set from -20 to 0 dBFS.

■ Setting the frequency



Set the frequency for the slate tone signal.

1. Press .

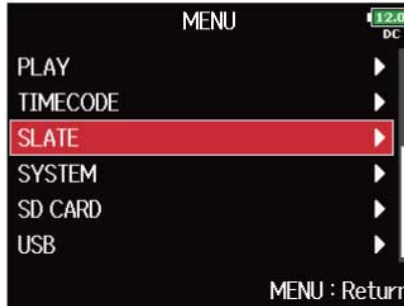

This opens the Menu Screen.

2. Use  to select "SLATE", and press .



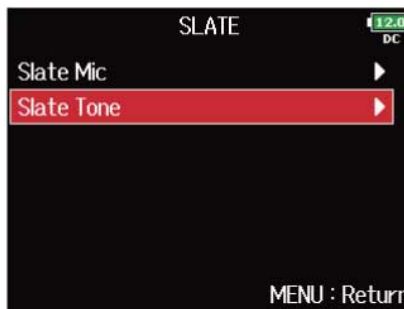

3. Use  to select "Slate Tone", and press .

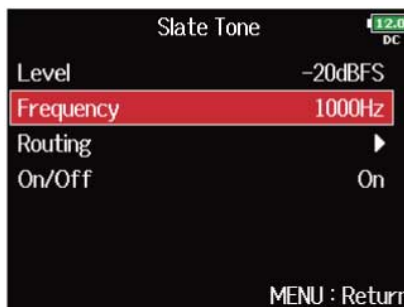

4. Use  to select "Frequency", and press .



5. Use  to adjust the frequency, and press  .

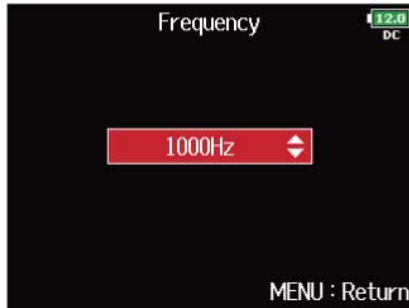

HINT:

This can be set from 100 to 10,000 Hz.

■ Setting the routing



Set the destination for the slate tone signal.

1. Press .

This opens the Menu Screen.

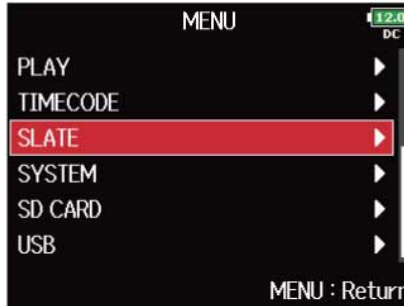
2. Use  to select "SLATE", and press .



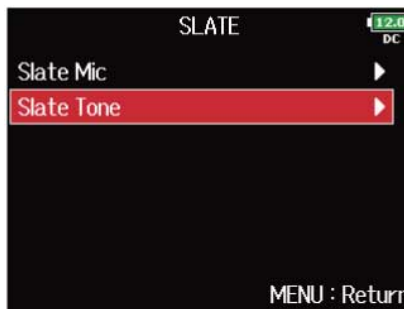

3. Use  to select "Slate Tone", and press .

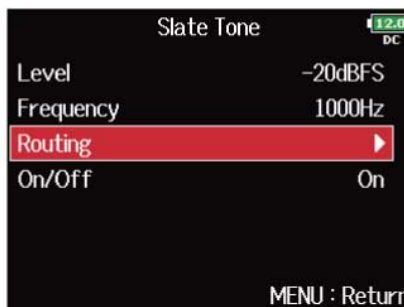

4. Use  to select "Routing", and press .



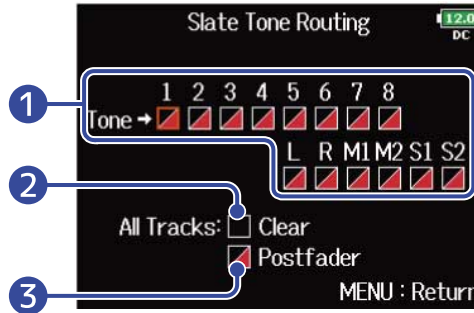

5. Use  to select the tracks/outputs for slate tone signal routing, and press .



1 Tracks/outputs for slate tone signal routing

Press  to switch between "Postfader" and "Off".

- : Postfader selected
- : Off

2 All Clear

This clears all settings.

3 Postfader setting

This sets all tracks to postfader.

NOTE:

Routing to tracks 1-8 is not possible when operating the as an audio interface (Stereo Mix). (→ [Using as an audio interface \(Audio Interface\)](#))

6. Press .

■ Recording

1. Press  to start recording.

2. Push  right toward the tone symbol and release.

NOTE:

- When the slate tone is in use, other signals input to the tracks that it is routed to are muted.
- The slate tone signal is always routed to the headphone L/R channels regardless of other routing settings.
- The MAIN OUT 1/2 and SUB OUT 1/2 faders do not affect the levels of the slate mic and slate tone.

HINT:

If you push and hold  right toward the tone symbol for one or more seconds, the slate tone will be enabled until you push the switch toward the tone symbol again.

■ Disabling the slate tone



You can set the slate tone so that it will not be enabled if  is accidentally pushed right toward the tone symbol.

1. Press .

This opens the Menu Screen.

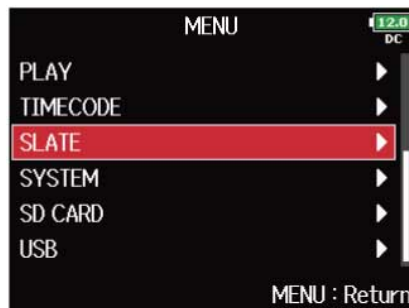
2. Use  to select "SLATE", and press .



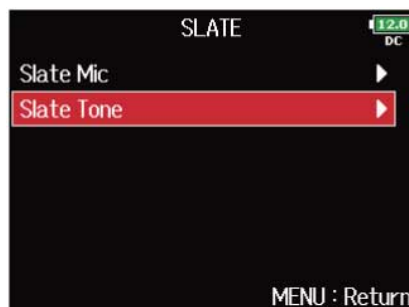

3. Use  to select "Slate Tone", and press .

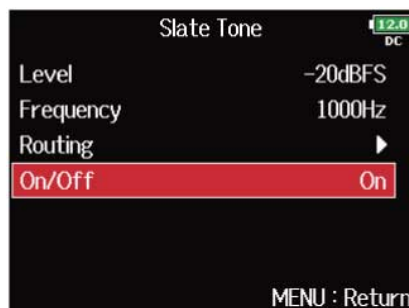

4. Use  to select "On/Off", and press .



5. Use  to select "Off (Lock)", and press .

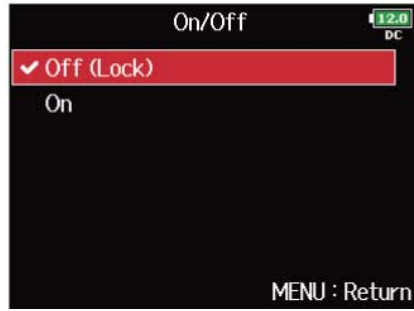

Recording

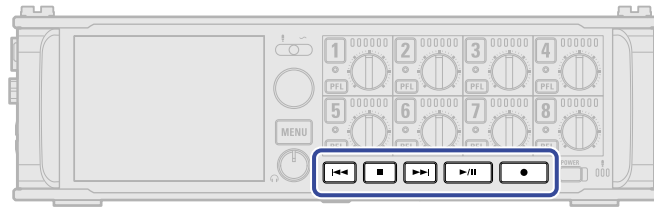

1. Press .

This starts recording.



2. Press  to start a new take when recording.

This will end the current take and start a new take while continuing to record without interruption.



3. Press  to pause.

4. Press  to stop.

NOTE:

- Pressing  during recording is only possible after recording for at least a second.
- When pausing, pausing will occur at a whole second increment.
- When recording is paused, a mark is added at that point. Press  to resume recording.
- A maximum of 99 marks can be added to a take.
- If the maximum file size is exceeded during recording (→ [Maximum file size \(File Max Size\)](#)), recording will continue in a new take with a number that is one higher. No gap in sound will occur between the two takes when this happens.
- When recording on 2 SD cards simultaneously, if recording should stop on one because it runs out of space, recording will continue on the other SD card without interruption.

HINT:

- If the timecode function is enabled, recording will start from frame 00 (00 or 02 when using drop frame) and files will always end exactly on a second. This makes synchronization easy when editing later. (→ [Using timecode](#))
- During playback, you can press  and  to jump to points where marks have been added.
- You can also add marks without pausing. (→ [Adding marks when recording/playing \(PLAY Key Option\)](#))
- Press and hold  when the HOME screen is open to check the name that will be given to the next take recorded.
- Files are automatically saved at regular intervals during recording. Even if the power is interrupted or another unexpected problem occurs during recording, an affected file can be restored to normal by playing it with the F8n Pro.

Playing recordings

Playing recordings

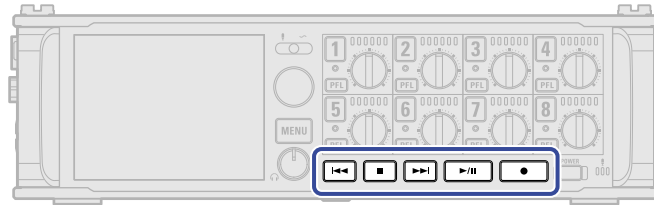

1. Press  .

■ Playback operations

Select take or jump to mark: Press  or  .

Search backward/forward: Press and hold  /  .



Pause/resume playback: Press  .

NOTE:

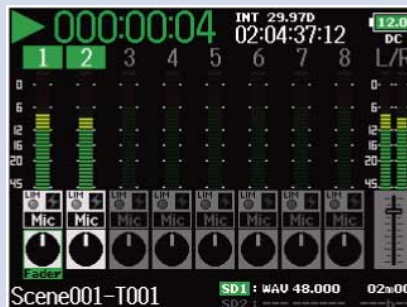
Tracks that have no playback files appear gray.



HINT:

- The longer you press and hold  /  , the faster the backward/forward search speed.
- During playback, press track keys to switch between playing back (lit green) and muted (unlit).
- An "Invalid Take!" message will appear if the selected take is not valid.
- A "No Take!" message will appear if no take exists.
- During playback, you can press  to add a mark that can be used for skipping. (→ [Adding marks when recording/playing \(PLAY Key Option\)](#))

2. Press  or  to return to the Home Screen.

Mixing takes

You can change the volume and panning of each track during playback.

1. Open the mixer on the Home Screen. (→ [Mixer Screen](#))

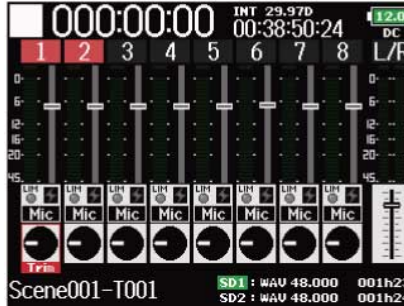

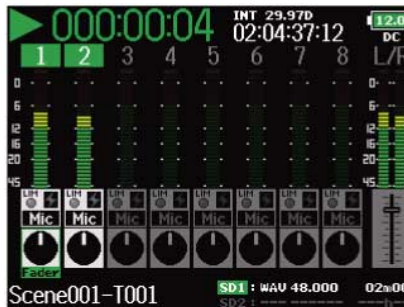

2. Press  to start playback.



3. Adjust the parameter settings.



■ Editing operations

Move cursor or change value: Turn .

Select parameter to change: Press .

| Parameter | Setting range | Explanation |
|-----------|------------------------|--|
| Fader | Mute, -48.0 - +24.0 dB | Adjusts the level of the input signal. |
| Panning | L100 - Center - R100 | Adjusts the left-right stereo position of the sound. |

NOTE:

- The pan cannot be adjusted when “Track Knob Option” is set to “Fader”. (→ [Setting the track knob function \(Track Knob Option\)](#))
- You can turn  to move the cursor, and also adjust the settings of the MAIN OUT 1/2 and SUB OUT 1/2 tracks. (→ [Setting output levels](#))
- When a fader or pan knob is selected, press and hold  to reset it to its default value. If already set to its default value, selecting a fader mutes the track.

HINT:

- Settings are saved separately for each take and are used during playback.
- Mix settings are not saved with the take when the format is MP3.

Monitoring the playback signals of specific tracks during playback

You can monitor the playback signals of specific tracks using SOLO mode.

1. Open the Home Screen. (→ [Home Screen](#))

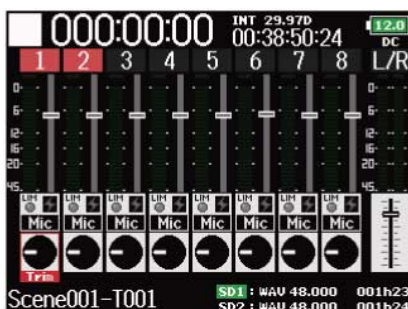

2. Press  to start playback.

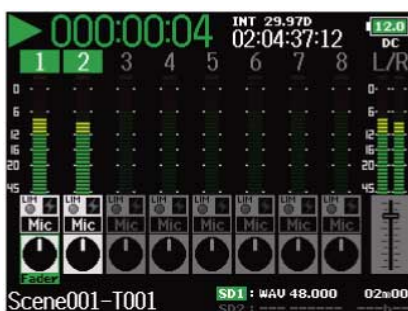

3. Press  on the tracks that you want to monitor.

The background colors for the selected tracks will become green, and their track indicators will light orange.

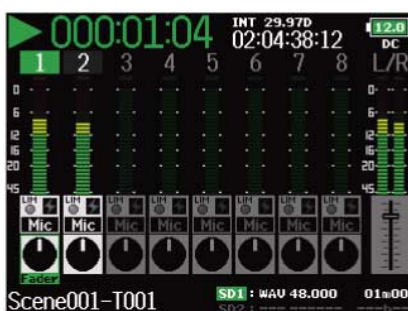

NOTE:

SOLO mode can only be used with tracks that can be played back (indicators lit green).



4. Press  of a track being monitored to stop monitoring it.

Changing the playback mode (Play Mode)



You can change the playback mode.

1. Press .

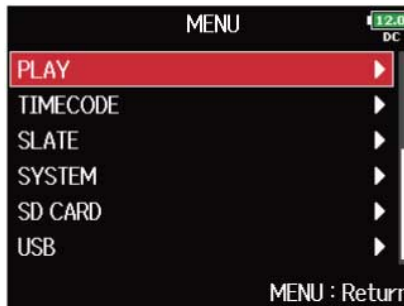

This opens the Menu Screen.

2. Use  to select "PLAY", and press .



3. Use  to select "Play Mode", and press .



4. Use  to select the play mode, and press .



| Setting | Explanation |
|--|---|
| Play One (single playback) | Only the selected take will be played. |
| Play All (all playback) | Takes will be played back continuously from the selected one until the last take. |
| Repeat One (single repeat playback) | The selected take will be played repeatedly. |
| Repeat All (all repeat playback) | All takes in the selected folder will be played repeatedly. |

Managing files

Folder and file structure

When recording with the F8n Pro, folders and files are created on SD cards as shown below. Folders and files are used to manage scenes and takes.

Folder and file structure

The folder and file structure differs according to the recording file format. In addition, the names of folders and files depend on how scenes are named.

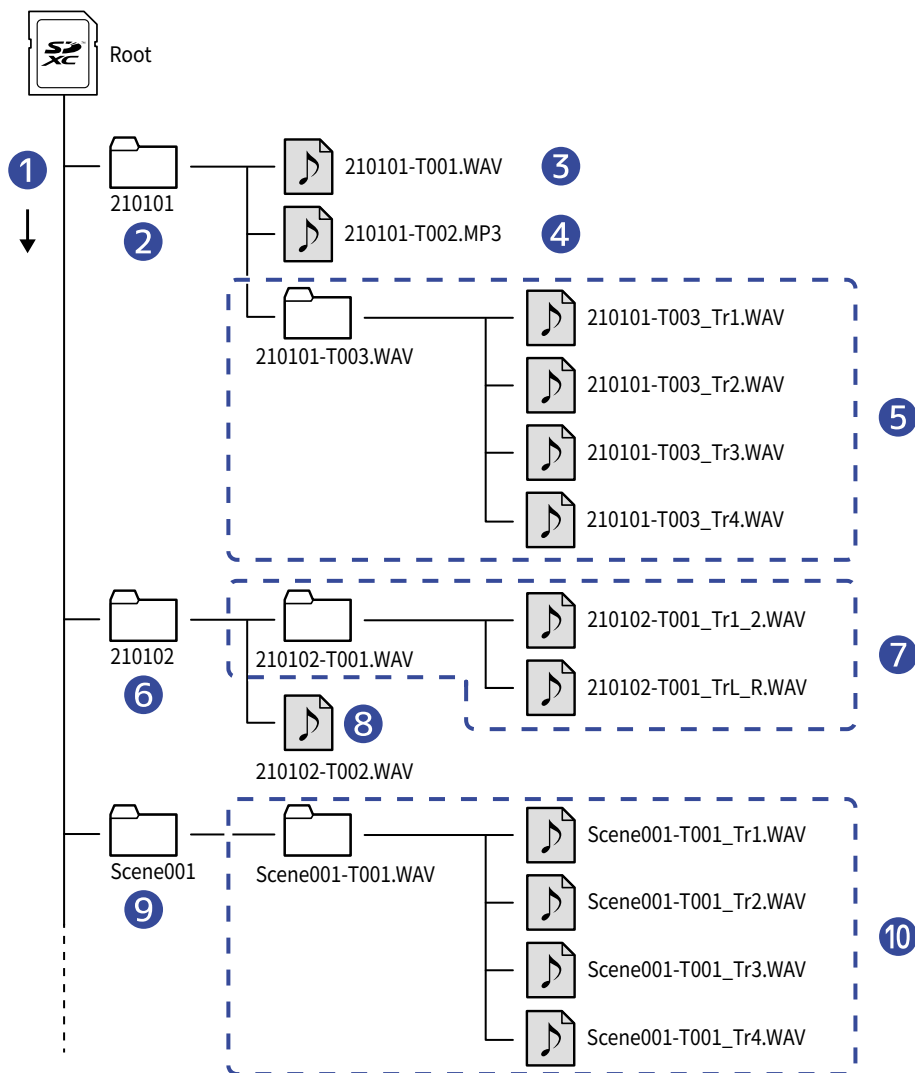

- 1 Order recorded
- 2 First scene
- 3 Scene 210101 (1st take)
WAV format, Poly file

- 4 Scene 210101 (2nd take)
MP3 format, Stereo file
- 5 Scene 210101 (3rd take)
WAV format, Mono files (tracks 1–4)
- 6 Next scene
- 7 Scene 210102 (1st take)
WAV format, Stereo file (track 1–2)
Stereo file (L/R tracks)
- 8 Scene 210102 (2nd take)
WAV format, Poly file
- 9 User created folder
- 10 Scene Scene001 (1st take)
WAV format, Mono files (tracks 1–4)



NOTE:

- Enabling recording on SD cards and setting file formats (→ [Enabling recording on SD cards and setting file formats](#))
- Setting how scenes are named (mode) (→ [Setting how scenes are named \(mode\)](#))

HINT:

- A “take” is a unit of data created for a single recording.
 - A “Scene” is a unit containing multiple files and takes that comprise a single scene.
-

Take names

| Structure | Explanation |
|--|--|
| <p style="text-align: center;">Scene001_T001</p> <p style="text-align: center;">① ② ③</p> <p>①: Scene name ②: Scene number (1-9999) ③: Take number (001-999)</p> | <ul style="list-style-type: none"> • Scene name: Select none, the folder name, the date or a name input by the user. (→ Setting how recorded scenes are named and numbered) • Scene number: Press  +  to advance the number by one. • Take number: This number increases by 1 for each recording made with the same scene name and number. |

Audio file names

File names are given by the F8n Pro according to the file format—poly, mono or stereo. Track numbers and other data are added to file names.

File names are given according to the following formats.

| Type | Structure | Explanation |
|-------------|---|---|
| Poly file | <p style="text-align: center;">Scene001_T001.wav</p> <p style="text-align: center;">①</p> <p>①: Take name</p> | This is a file created by poly recording. Audio for multiple tracks is recorded to a single file. |
| Mono file | <p style="text-align: center;">Scene001_T001_Tr1.wav</p> <p style="text-align: center;">① ②</p> <p>①: Take name ②: Track number</p> | This is a file created by mono recording. |
| Stereo file | <p style="text-align: center;">Scene001_T001_Tr1_2.wav</p> <p style="text-align: center;">① ②</p> <p>①: Take name ②: Track number</p> | This is a file created by stereo recording. |

HINT:

When recording with the “Mono/Stereo WAV” setting, the audio files are saved in the take folder that is created. (→ [Enabling recording on SD cards and setting file formats](#))



Take and folder operations (FINDER)

The FINDER allows you to select and view the contents of SD cards, takes and folders, and to create project/scene folders. It also allows you to, for example, set and delete recording/playback folders and view their information.

Selecting SD cards, folders and takes

1. Press .

This opens the Menu Screen.

2. Use  to select "FINDER", and press .

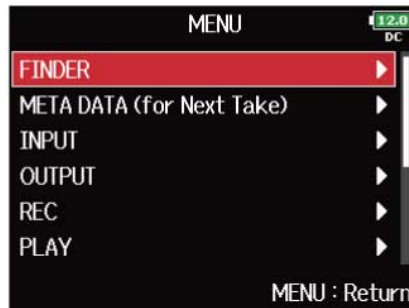

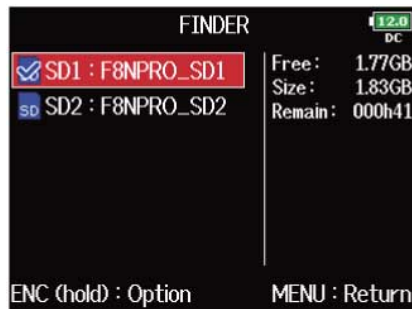

3. Turn  to select the SD card, folder or take that you want to use.



■ Editing operations

Move cursor: Turn .

Move down a level: Press .

Move up a level: Press .

■ SD card selected



- 1 Free space
- 2 Size
- 3 Recordable time

■ Folder selected





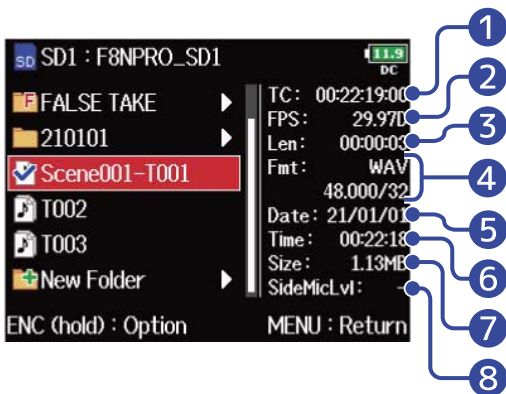

- 1 Date
- 2 Time

■ Take selected



- 1 Timecode
- 2 Frame rate
- 3 Length
- 4 Recording format
- 5 Date created
- 6 Time created
- 7 Size
- 8 MS Side mic level

NOTE:

- When the cursor is on a take, you can press  to play the selected take. You can also use ,  and .
- A check mark appears on the playback take and recording/playback folder.

Creating folders

Folders can be created inside the currently selected SD card/folder.

1. Select the SD card or folder in which you want to make a folder (see [“Selecting SD cards, folders and takes”](#)), and press .

This shows the files and folders in the selected SD card or folder.

2. Use  to select “New Folder”, and press .



3. Edit the folder name.



See [“Character input screen”](#) for how to input characters.



NOTE:

- The folder created will be set as the recording folder.
- The name of the folder created is written to the <PROJECT> or <SCENE> metadata.
- You cannot put a space or an @ mark at the beginning of the name.

Selecting the take recording/playback folder

Use this procedure to select the folder that contains the take to be played or the folder to use for recording takes.

1. Select the folder (see [“Selecting SD cards, folders and takes”](#)).

2. Press and hold  to display the Option screen, use  to select “Select”, and press .

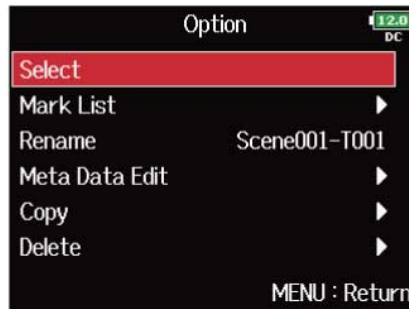

After selecting the take recording/playback folder, the Home Screen will reopen.
A check mark appears on the selected folder.



NOTE:

The first take inside the selected SD card or folder will be set as the playback take.



Checking take marks and using them for playback

You can view a list of the marks in a recorded take.

1. Select the take with the mark list that you want to view (see [“Selecting SD cards, folders and takes”](#)).

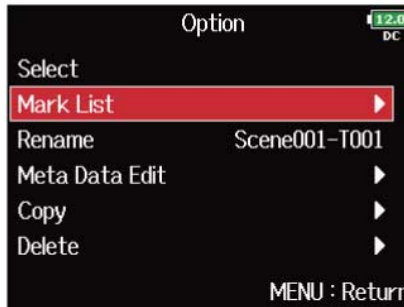
2. Press and hold  to display the Option screen, use  to select “Mark List”, and press .



3. Use  to select a mark, and press .

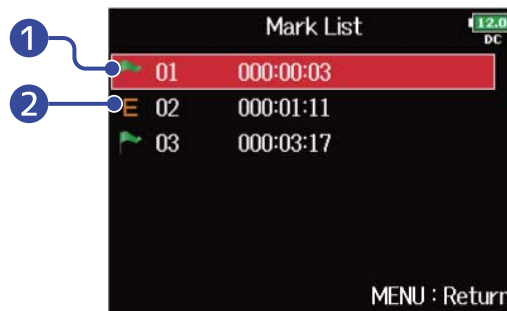



1 Added Mark

2 Indicates that a mark was added during a recording error.

The Home Screen will reopen, and playback will start from the mark.

Changing folder and take names

1. Select the folder or take with the name that you want to change (see [“Selecting SD cards, folders and takes”](#)).

2. Press and hold  to display the Option screen, use  to select “Rename”, and press .

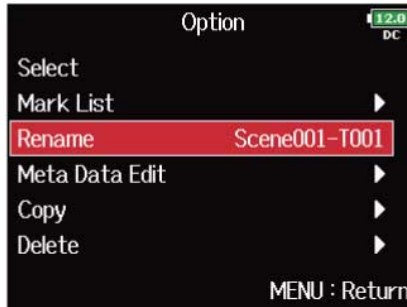

3. Edit the folder/take name.

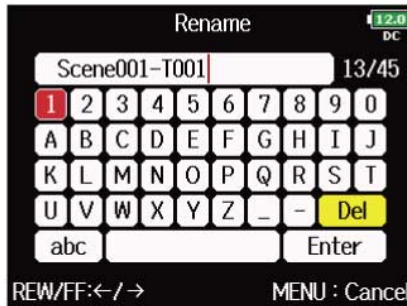



See [“Character input screen”](#) for how to input characters.



NOTE:

- The edited name of the folder/take is written to the <PROJECT> or <SCENE> metadata.
- You cannot put a space or an @ mark at the beginning of the name.

Copying takes to other cards and folders

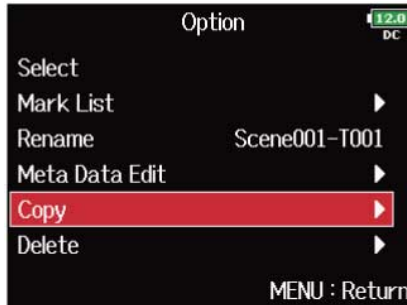

1. Select the take that you want to copy (see [“Selecting SD cards, folders and takes”](#)).
2. Press and hold  to display the Option screen, use  to select “Copy”, and press .

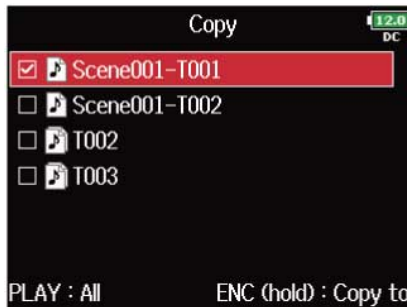

3. Use  to select the take to copy, and press .



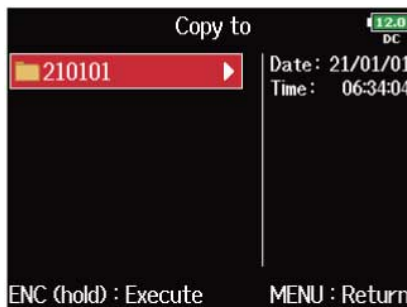

4. Press and hold .

5. Use  to select the copy destination, and press and hold .



NOTE:



For how to select the folder, see [“Selecting SD cards, folders and takes”](#).

6. Use  to select "Yes", and press .





Deleting folders and takes

1. Select the folder/take that you want to delete (see [“Selecting SD cards, folders and takes”](#)).

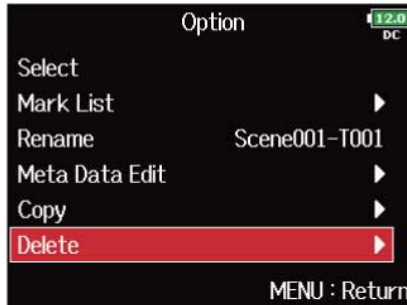
2. Press and hold  to display the Option screen, use  to select “Delete”, and press .





3. Use  to select the folder/take to delete, and press .

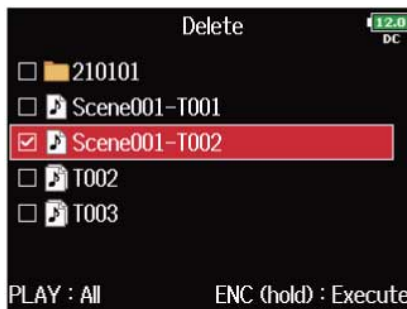

Press  to cancel deletion.



NOTE:

You can press  to select/deselect all the folders and takes that are currently shown.

4. Press and hold .

5. Use  to select "Yes", and press .



NOTE:

- Deleted folders and takes are not immediately erased from the SD card. They are moved to the TRASH folder.
- Deleting the folders and takes in the TRASH folder will completely erase their data.

Emptying the TRASH/FALSE TAKE folder

1. Select "TRASH" or "FALSE TAKE" (see "[Selecting SD cards, folders and takes](#)").



TRASH folder





FALSE TAKE folder



2. Press and hold .

3. Use  to select "Empty", and press .



4. Use  to select "Yes", and press .



NOTE:

- Emptying the TRASH folder will completely erase the data in it.
- Emptying the FALSE TAKE folder will not immediately erase the data in it from the SD card. Instead, this data will be moved to the TRASH folder.

Overview of take information (metadata) stored in files

The F8n Pro writes a variety of information (metadata) to files during recording.

When these files are read by an application that supports metadata, you will be able to check and use the saved information.

HINT:

- Metadata is data that contains information related to other data. The F8n Pro saves scene names and take numbers, for example, as metadata in audio files.
 - A chunk is a unit that contains multiple data in a single block.
 - To use BEXT and iXML chunk metadata, an application that supports both data formats is necessary.
-

■ WAV file metadata

The metadata saved in files recorded by the in WAV format is collected in BEXT (Broadcast Audio Extension) and iXML chunks.

For information about the metadata saved in these chunks, see [“Metadata contained in BEXT chunks in WAV files, Metadata contained in iXML chunks in WAV files”](#).

■ MP3 file metadata

The metadata saved in files recorded by the F8n Pro in MP3 format is written as ID3v1 tags.

For information about the ID3 fields and formats for saving metadata, see the [“Metadata and ID3 fields contained in MP3 files”](#).

HINT:

- F8n Pro MP3 files conform to the MPEG-1 Layer III standard.
 - MP3 metadata cannot be edited.
-



Checking and editing take metadata

Use the metadata editing screen to check/edit take metadata.



Opening the metadata editing screen

1. Press .

This opens the Menu Screen.

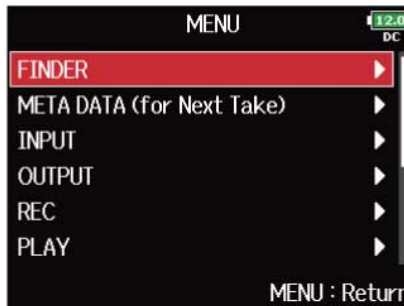
2. Use  to select "FINDER", and press .



3. Use  to select the take, and press and hold .

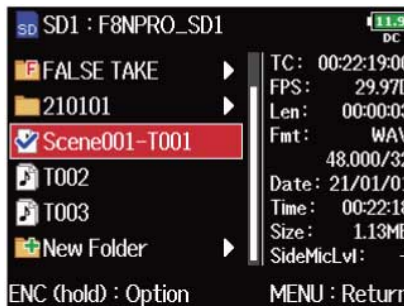

This opens the Option Screen.

HINT:

For how to select takes, see ["Selecting SD cards, folders and takes"](#).

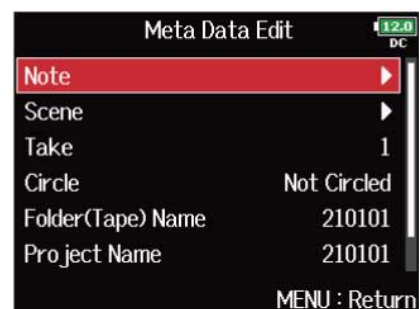
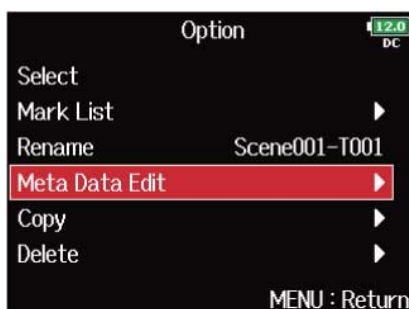

4. Use  to select "Meta Data Edit", and press .

This opens the metadata editing screen.





Checking and editing notes

1. Open the metadata editing screen. (→ [Opening the metadata editing screen](#))

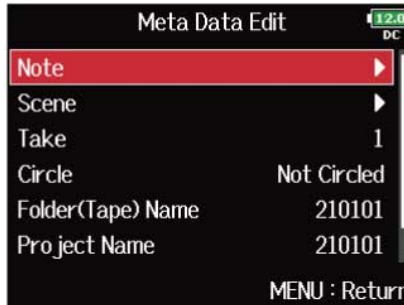
2. Use  to select "Note", and press .



3. Use  to select "Edit", and press .

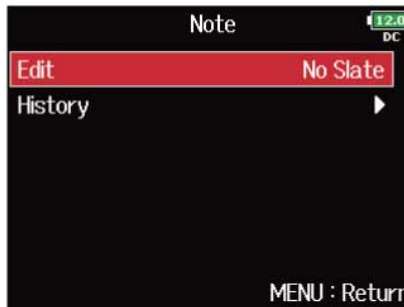

4. Edit the note.

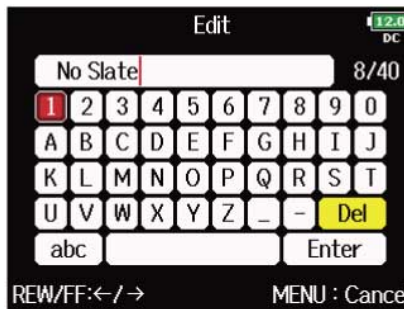



See "[Character input screen](#)" for how to input characters.

NOTE:



The content of this note is written to the <NOTE> metadata.

HINT:

You can select notes from the history list.

1. Use  to select "History", and press  in step 3.





2. Use  to select the item to use , and press .





The history list will be erased if the "Factory Reset" function is used. (→ [Restoring factory default settings](#))

Checking and editing scene names

1. Open the metadata editing screen. (→ [Opening the metadata editing screen](#))

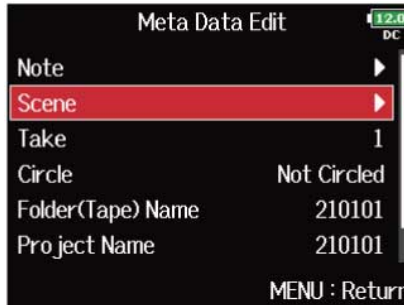
2. Use  to select "Scene", and press .



3. Use  to select "Edit", and press .



4. Edit the scene name.

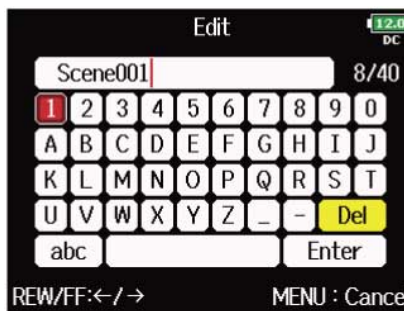



See "[Character input screen](#)" for how to input characters.

NOTE:



The scene name is written to the <SCENE> metadata.

HINT:

You can select a scene name from the history list.

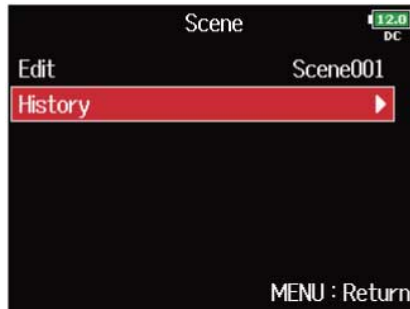
1. Use  to select "History", and press  in step 3.



2. Use  to select the item to use , and press .



The history list will be erased if the "Factory Reset" function is used. (→ [Restoring factory default settings](#))

Checking and editing take number

1. Open the metadata editing screen. (→ [Opening the metadata editing screen](#))

2. Use  to select "Take", and press .

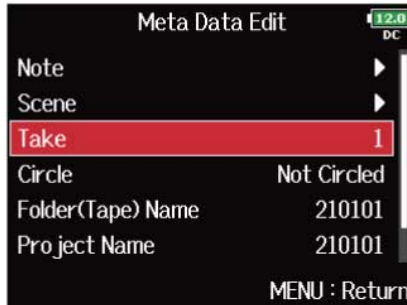

3. Change the take number.

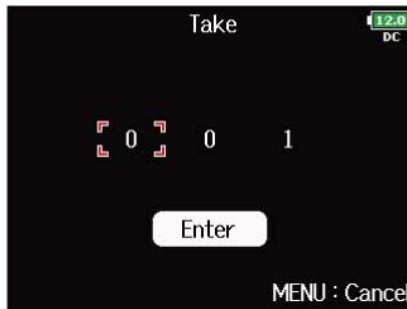

■ Editing operations

Move cursor or change value: Turn .

Select parameter to change: Press .

NOTE:

The take number is written to the <TAKE> metadata.

HINT:

This can be set from 1 to 999.

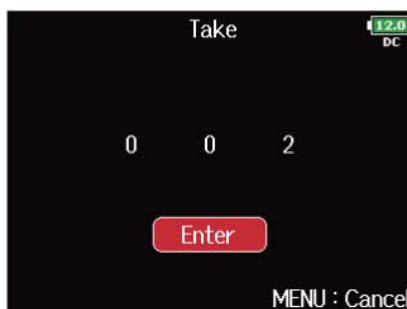

4. When done changing, use  to select "Enter", and press .





Setting the circling takes

Use this function to add an @ mark to the beginning of the name of the best take to make it stand out. This is called a "circled take".

1. Open the metadata editing screen. (→ [Opening the metadata editing screen](#))

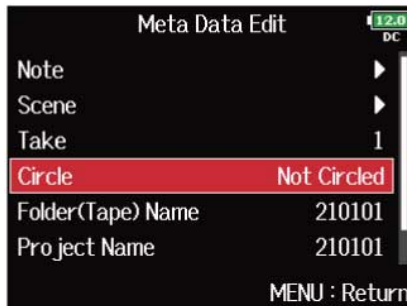
2. Use  to select "Circle", and press .



3. Use  to select "Circled", and press .

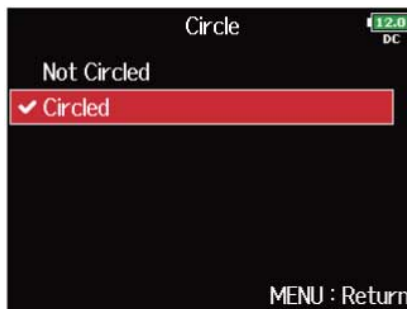



NOTE:

- To clear a circle, select "Not Circled" and press .
- This circled status is written to the <CIRCLE> metadata.

Editing folder (tape) names

1. Open the metadata editing screen. (→ [Opening the metadata editing screen](#))

2. Use  to select "Folder (Tape) Name", and press .

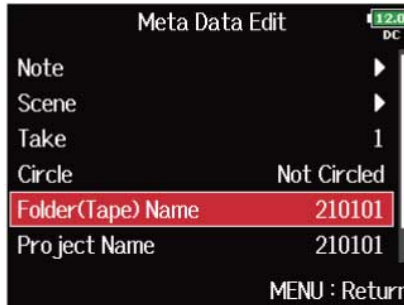

3. Edit the folder (tape) name.

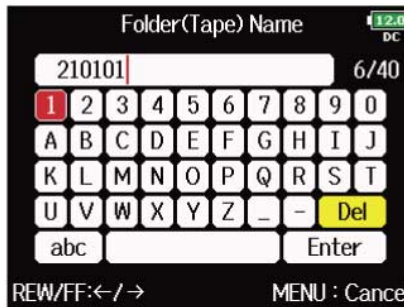

See "[Character input screen](#)" for how to input characters.

NOTE:

- The folder (tape) name is written to the <TAPE> metadata.
- The folder (tape) name used immediately after recording is the name of the folder in which the take was recorded.

Editing project names

1. Open the metadata editing screen. (→ [Opening the metadata editing screen](#))

2. Use  to select "Project Name", and press .

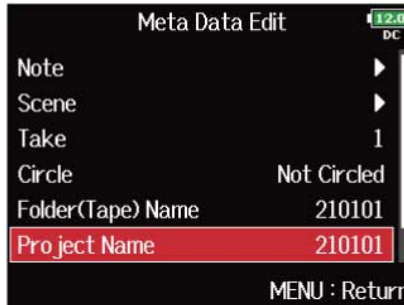

3. Edit the project name.

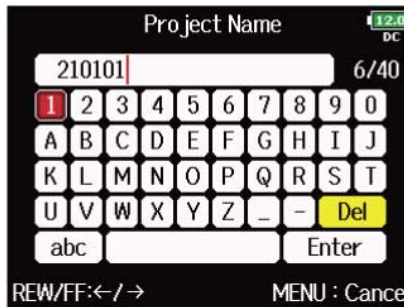



See "[Character input screen](#)" for how to input characters.

NOTE:



- The project name is written to the <PROJECT> metadata.
- The project name used immediately after recording includes the name of the highest level folder (inside the SD card root directory) that contains the folder in which the take was recorded.

Checking and editing track names

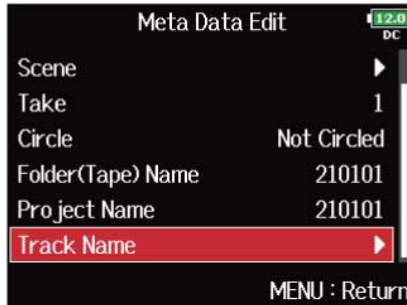

1. Open the metadata editing screen. (→ [Opening the metadata editing screen](#))

2. Use  to select "Track Name", and press .

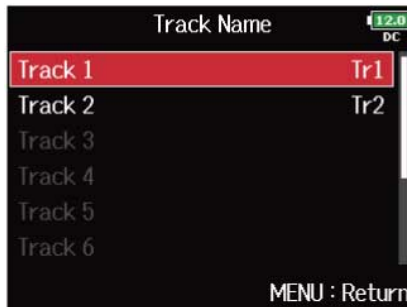

3. Use  to select a track, and press .



4. Use  to select "Edit", and press .

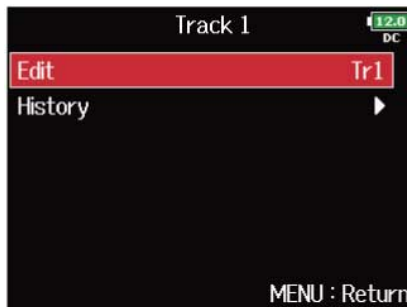

5. Edit the track name.

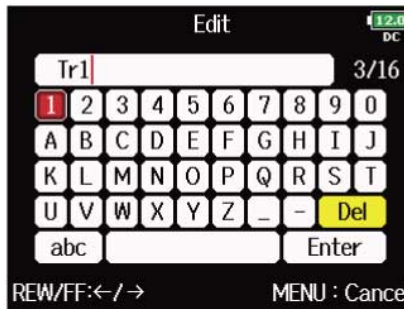



See "[Character input screen](#)" for how to input characters.

NOTE:



The track name is written to the <TRACK> <NAME> metadata.

HINT:

You can select a track name from the history list.

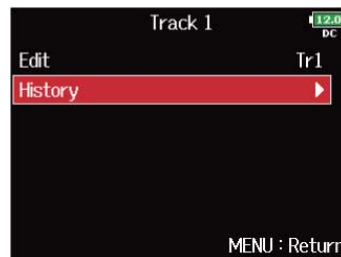
1. Use  to select "History", and press  in step 4.



2. Use  to select the item to use, and press .

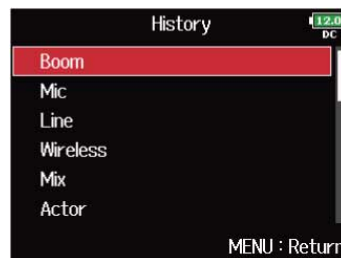



The history list will be erased if the "Factory Reset" function is used. (→ [Restoring factory default settings](#))

Writing sound reports (Create Sound Report)



A sound report includes information about recording times and takes. Reports can be written as CSV format files (F8n Pro_“folder name”.CSV). You can edit the comments written in sound reports.

1. Press .

This opens the Menu Screen.

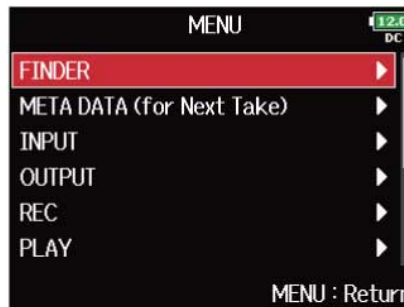
2. Use  to select “FINDER”, and press .



3. Use  to select the folder or SD card for which you want to create a sound report, and press and hold .

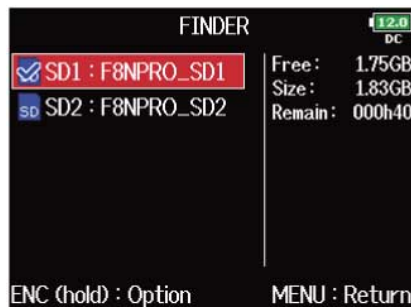



This opens the Option Screen.

HINT:

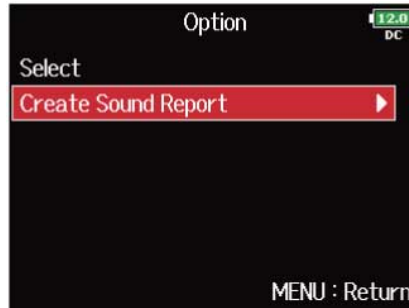

For how to select folders and SD cards, see [“Selecting SD cards, folders and takes”](#).

4. Use  to select "Create Sound Report", and press .



5. Use  to select "Create", and press .



6. Use  to select "Yes", and press .

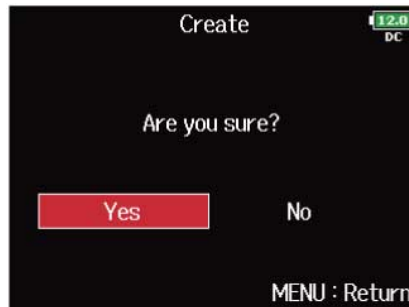

This writes the sound report inside the selected SD card or folder.

NOTE:

- Only information about takes in the folder or SD card is written in the sound report.
- If a sound report file with the same name already exists, it will be overwritten. Please use caution.



Editing sound report comments

1. In step 5 of [“Writing sound reports \(Create Sound Report\)”](#), use  to select “Info Edit”, and press



2. Use  to select “Comments”, and press .



3. Use  to select “Edit”, and press .



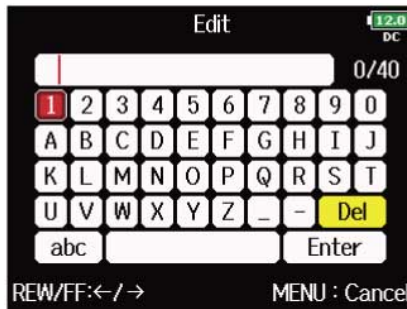

4. Edit the comment.





See "[Character input screen](#)" for how to input characters.

HINT:

You can select comments from the history list.

1. Use  to select "History", and press  in step 3.



2. Use  to select the item to use, and press .



The history list will be erased if the "Factory Reset" function is used. (→ [Restoring factory default settings](#))

Using USB functions



Exchanging data with a computer (SD Card Reader)

By connecting the F8n Pro to a computer, you can check and copy data on SD cards.

Connecting to a computer

1. Press .

This opens the Menu Screen.

2. Use  to select "USB", and press .

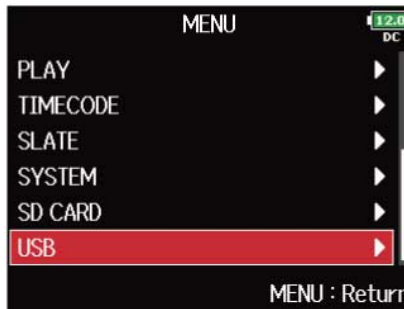

3. Use  to select "SD Card Reader", and press .

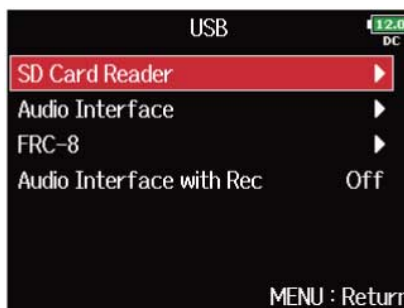

4. Connect the F8n Pro and computer with a USB cable.

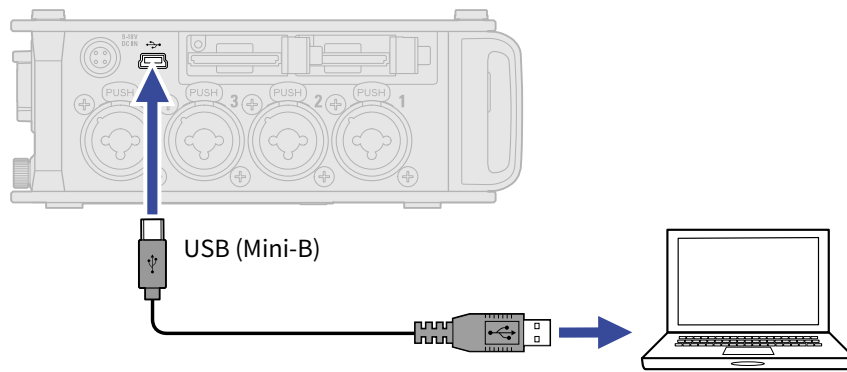

NOTE:

- Use a USB cable that supports data transfer.
- The F8n Pro cannot operate on USB bus power. Use the internal batteries, the dedicated AC adapter or an external DC power supply to power it.

HINT:

When the F8n Pro is connected to a computer, the SD cards loaded in slots 1 and 2 are recognized as separate SD cards.

■ Disconnecting a computer

1. Disconnect on the computer.

- Windows:
Select F8n Pro from the “Safely Remove Hardware and Eject Media” icon on the bottom of the computer screen.
- macOS:
Drag and drop the F8n Pro icon to the Trash.

2. Disconnect the cable from the computer and the F8n Pro, and press .

NOTE:

Always conduct the removal procedure in step 1 before disconnecting the USB cable.

Using as an audio interface

Signals input to the F8n Pro can be sent to a computer or iOS/iPadOS device, and playback signals from a computer or iOS/iPadOS device can be output from the F8n Pro.

Precautions when using 32-bit float format:

- Before using, confirm that the app used on your computer or iOS/iPadOS device supports 32-bit float format.
- Before connecting the F8n Pro to speakers or headphones, set the F8n Pro headphone volume and output level of the MAIN OUT 1/2 and SUB OUT 1/2 to a minimum. Using an app that does not support 32-bit float format could make an unexpected loud noise and damage your ears.

Installing drivers

■ Windows computers

1. Download the F8n Pro Driver to the computer from zoomcorp.com.
2. Launch the installer and follow its instructions to install the F8n Pro Driver.

NOTE:

See the "Installation Guide" included in the driver package for detailed installation procedures.

■ Mac computers and iOS/iPadOS devices

No drivers are necessary for use with Mac computers and iOS/iPadOS devices.

Using as an audio interface (Audio Interface)



■ Connecting to a computer or an iOS/iPadOS device

1. Press .

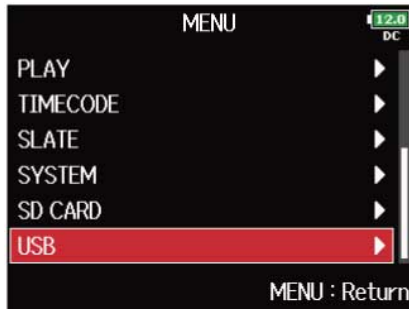

This opens the Menu Screen.

2. Use  to select "USB", and press .



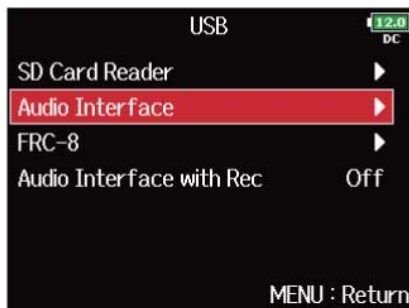

3. Use  to select "Audio Interface", and press .



4. Use  to select the mode, and press .



| Setting | Explanation |
|----------------------|---|
| Stereo Mix (iPad) | This is a 2-in/2-out connection mode for iOS/iPadOS devices and sends tracks 1–8 as a stereo mix. |
| Multi Track (PC/Mac) | <p>This is an 8-in/4-out connection mode for Mac/Windows and sends tracks 1–8 as separate signals (cannot be used with an iOS device).</p> <p>The screen for selecting the operation mode opens. Use  to select the operation mode, and press .</p> <div data-bbox="839 987 1246 1292" data-label="Image"> <p>The screenshot shows a black menu titled 'Multi Track (PC/Mac)' with a battery icon and 'DC' indicator in the top right. Two options are listed: 'Linear' which is highlighted with a red bar and a right-pointing arrow, and 'Float' with a right-pointing arrow. At the bottom, it says 'MENU : Return'.</p> </div> <ul data-bbox="580 1317 1501 1496" style="list-style-type: none"> • Linear: This sets the bit depth during audio interface use to 24-bit Linear. • Float: This sets the bit depth during audio interface use to 32-bit Float. |

5. Use a USB cable to connect the F8n Pro and the computer or iOS/iPadOS device.

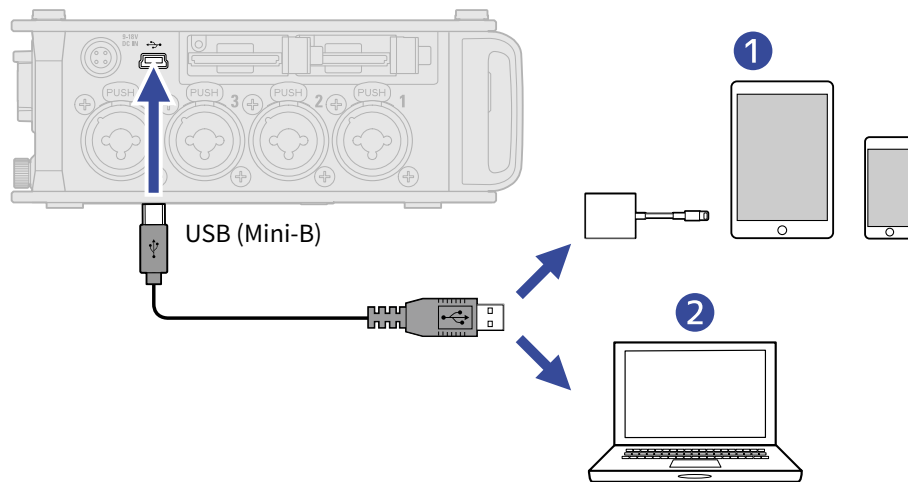

- 1 iOS/iPadOS device
- 2 Computer (Windows/Mac)

The audio interface screen opens.



- 1 Operation mode
This shows the current operation mode.



NOTE:

- Use a Lightning to USB 3 Camera Adapter to connect to an iOS/iPadOS device.
- Use a USB cable that supports data transfer.
- The F8n Pro cannot operate on USB bus power. Use the internal batteries, the dedicated AC adapter or an external DC power supply to power it.
- When the F8n Pro is used as an audio interface and the sampling rate is set to 44.1/48 kHz, latency increases 2 ms. When latency increases while monitoring sounds being recorded with a mic in real-time, interference occurs between sound transmitted through the air from the source and the delayed monitored sound, possibly making accurate monitoring of the sounds difficult.



Disconnecting

1. Press .

This opens the Menu Screen.

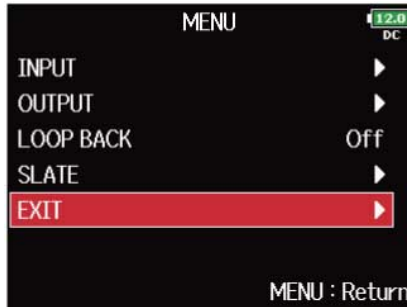
2. Use  to select "EXIT", and press .



3. Use  to select "Yes", and press .



4. Disconnect the cable from the computer or iOS/iPadOS device and the F8n Pro.

NOTE:

Always conduct the removal procedure in steps 1 to 3 before disconnecting the USB cable.



Using SD card recording and audio interface functions at the same time (Audio Interface with Rec)

In addition to the two SD cards, a computer can also be used for recording backup.

■ Connecting to a computer

1. Press .

This opens the Menu Screen.

2. Use  to select "USB", and press .

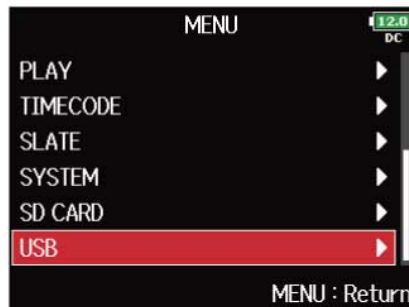

3. Use  to select "Audio Interface with Rec", and press .

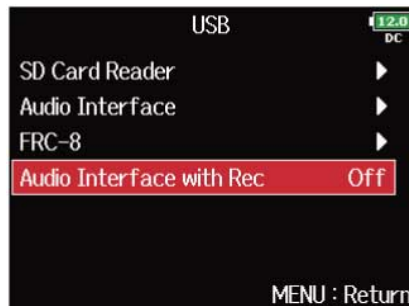

4. Use  to select "On", and press .

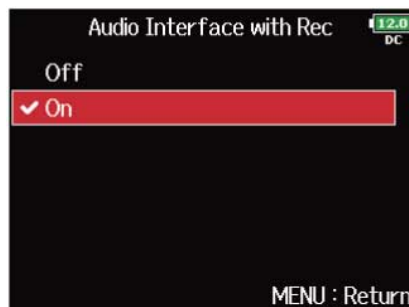

5. Use a USB cable to connect the F8n Pro and the computer.

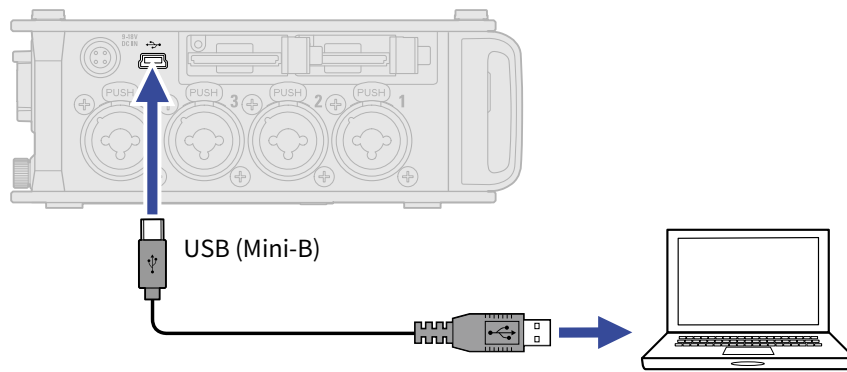



NOTE:

- Use a USB cable that supports data transfer.
- The F8n Pro cannot operate on USB bus power. Use the internal batteries, the dedicated AC adapter or an external DC power supply to power it.
- “Audio Interface with Rec” cannot be used with the following settings and functions.
 - Sampling rate settings other than 44.1/48 kHz (→ [Setting the sampling rate \(Sample Rate\)](#))
 - “SD Card Reader” (→ [Exchanging data with a computer \(SD Card Reader\)](#))
 - “Audio Interface” (→ [Using as an audio interface \(Audio Interface\)](#))
 - FRC-8 (→ [Using the FRC-8](#))
- When “Audio Interface with Rec” is set to “On”, the sampling rate cannot be changed. (→ [Setting the sampling rate \(Sample Rate\)](#))
- When “Audio Interface with Rec” is set to “On”, files with sampling rates that differ from the F8n Pro setting cannot be played. (→ [Setting the sampling rate \(Sample Rate\)](#))
- When “Audio Interface with Rec” is set to “On”, “WAV Bit Depth” cannot be changed. (→ [Setting WAV file bit depth \(WAV Bit Depth\)](#))
- Set the input source to USB 1–4 (→ [Setting the input source \(Input Source\)](#)) or set USB 1–4 to the output routing (→ [Setting signals sent to headphones \(Headphone Routing\)](#), [Selecting signals sent to the main outputs \(MAIN OUT Routing\)](#), [Selecting signals sent to the sub outputs \(SUB OUT Routing\)](#)) to monitor sound played back from the computer.
- When “Audio Interface with Rec” is set to “On”, the F8n Pro latency will increase 2 ms. When monitoring sounds being recorded with a mic in real-time, increased latency can cause interference between sound transmitted through the air from the source and the delayed monitored sound, possibly making accurate monitoring of the sounds difficult.
- The audio interface operation mode changes depending on the “WAV Bit Depth” setting. (→ [Setting WAV file bit depth \(WAV Bit Depth\)](#))
 - “16-bit Linear”/“24-bit-Linear”: The bit depth during audio interface use is set to 24-bit Linear.
 - “32-bit Float”: The bit depth during audio interface use is set to 32-bit Float.

Disconnecting

1. Press .

This opens the Menu Screen.

2. Use  to select "USB", and press .

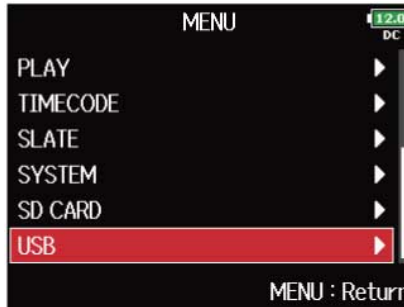

3. Use  to select "Audio Interface with Rec", and press .

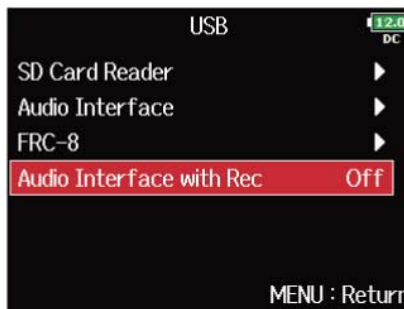

4. Use  to select "Off", and press .

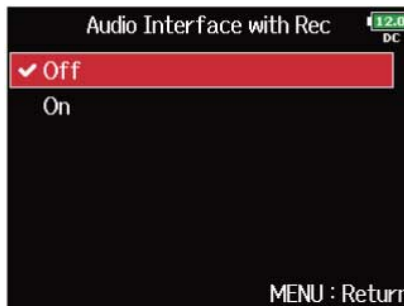

5. Disconnect the cable from the computer and the F8n Pro.

NOTE:

Always conduct the removal procedure in steps 1 to 4 before disconnecting the USB cable.

Audio interface block diagrams

■ Stereo Mix

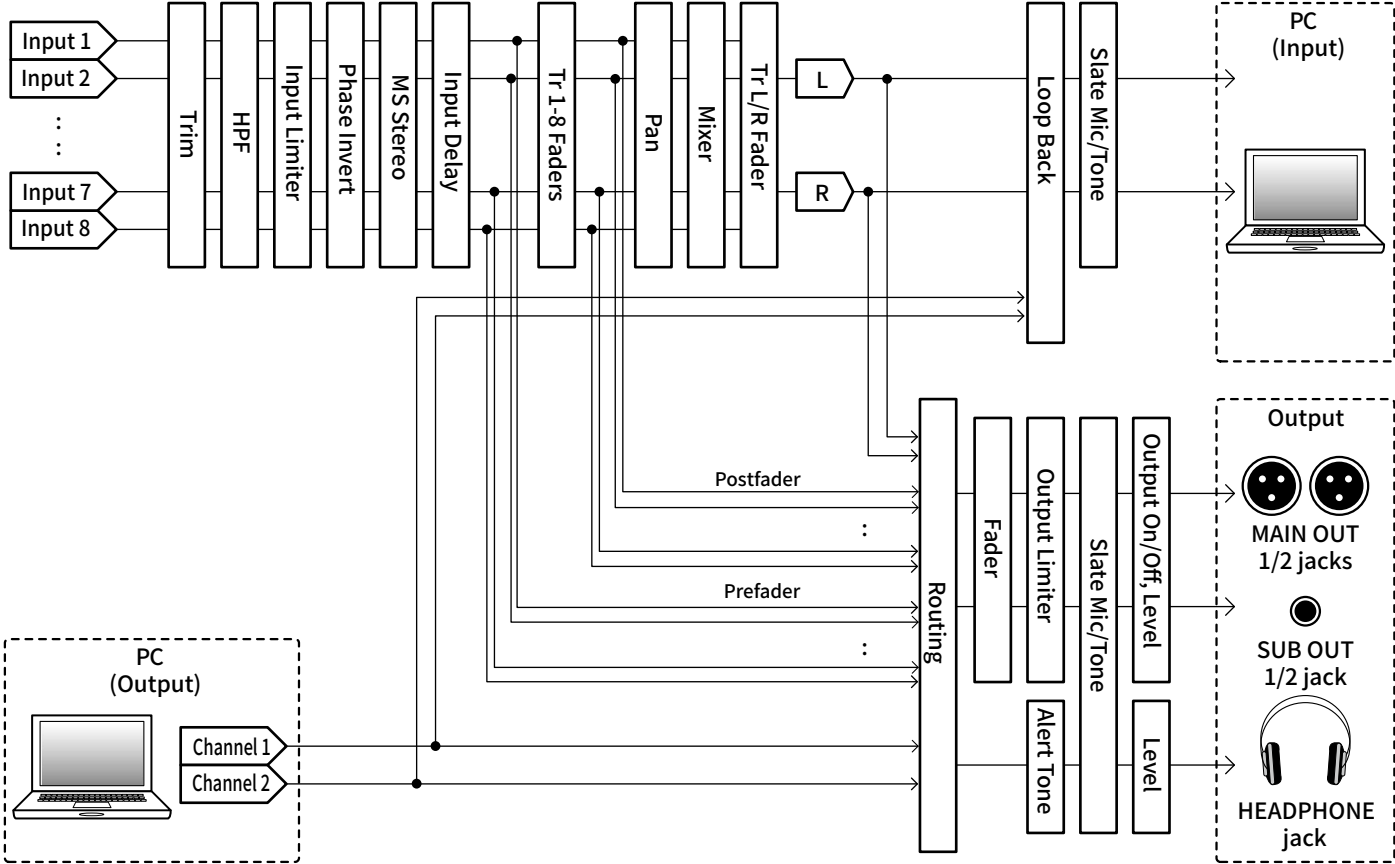

Multi Track

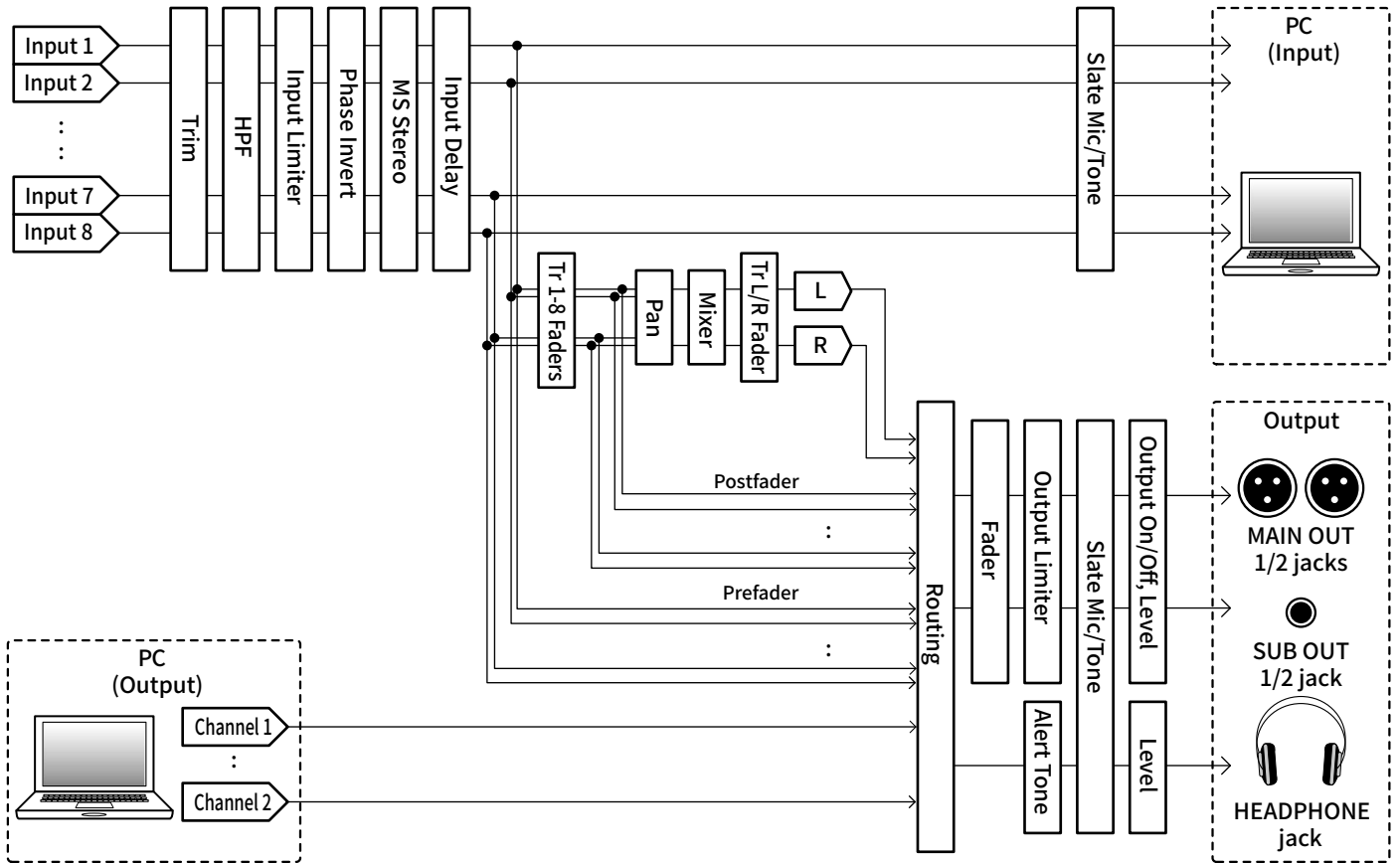

Making audio interface settings

■ Setting loop back (Stereo Mix only)

This function allows the playback sound from the computer or iOS/iPadOS device and the F8n Pro inputs to be mixed and sent back to the computer or iOS/iPadOS device (loop back).

You can use this function to add narration to music played back from the computer and record the mix or stream it from the computer, for example.

1. Press .

This opens the Menu Screen.

2. Use  to select "LOOP BACK", and press .

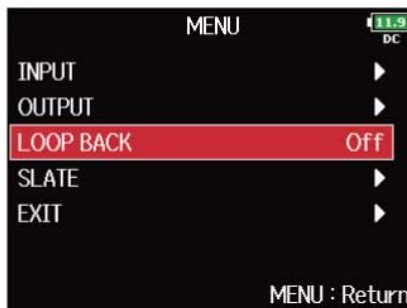

3. Use  to select "On", and press .

■ Mixing inputs

You can adjust the mix balance of input signals sent to the computer or iOS/iPadOS device. When "Audio Interface" is set to "Stereo Mix", the mixed stereo signal will be sent. (→ [Using as an audio interface \(Audio Interface\)](#))

1. Open the mixer on the Home Screen. (→ [Mixer Screen](#))



2. Adjust the parameter settings.

See "[Adjusting the input signal monitoring balance](#)" for how to change settings.



Using the FRC-8

Using the FRC-8 as a controller (Connect)

By connecting the FRC-8 to the F8n Pro, you can use it to adjust trim, fader and pan settings, for example.

1. Press .

This opens the Menu Screen.

2. Use  to select "USB", and press .

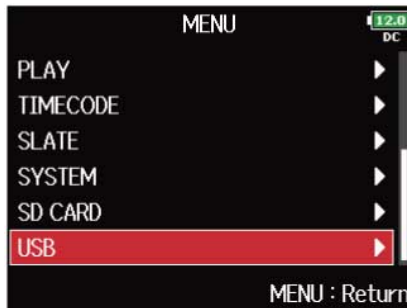

3. Use  to select "FRC-8", and press .

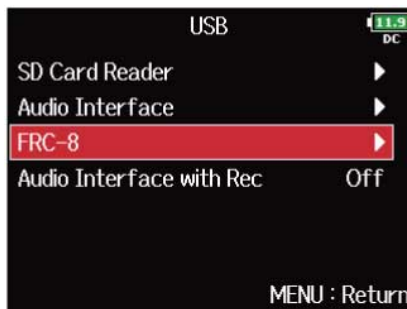

4. Use a USB cable to connect the F8n Pro and the FRC-8.

5. Turn the FRC-8 power ON.

6. Use  to select "Connect", and press .

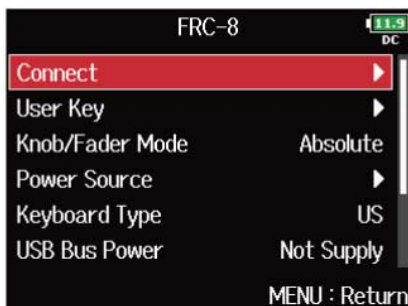

NOTE:



When disconnecting the FRC-8, select "Disconnect" before unplugging the USB cable.

Setting the type of keyboard connected to the FRC-8 (Keyboard Type)

You can connect a PC keyboard to the FRC-8 and use it to input characters.
Set the type of PC keyboard connected to the FRC-8.

1. Press .

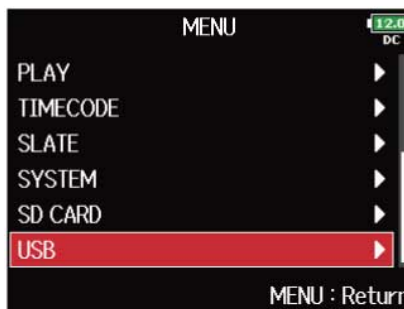

This opens the Menu Screen.

2. Use  to select "USB", and press .



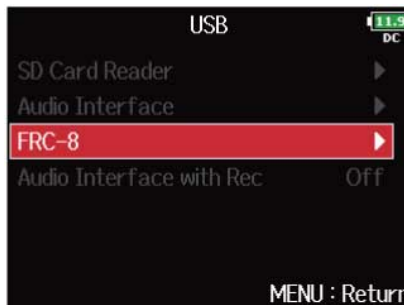

3. Use  to select "FRC-8", and press .

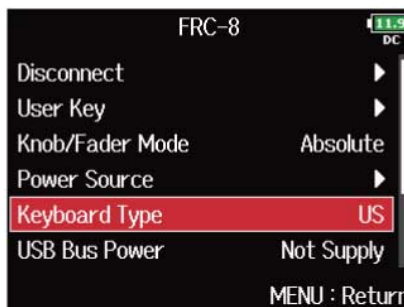

4. Use  to select "Keyboard Type", and press .



5. Use  to select the type, and press .

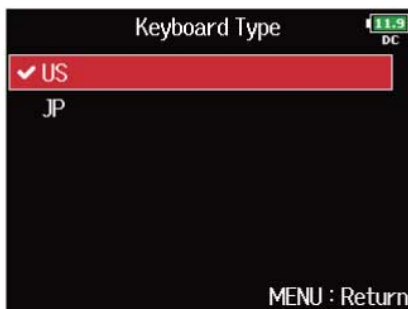



| Setting | Explanation |
|---------|-------------------------------------|
| US | Use for English-language keyboards. |
| JP | Use for Japanese keyboards. |

Setting FRC-8 fader and knob operation (Knob/Fader Mode)

How the FRC-8 faders and TRIM/PAN knobs operate when their positions differ from actual parameter values can be set.

1. Press .

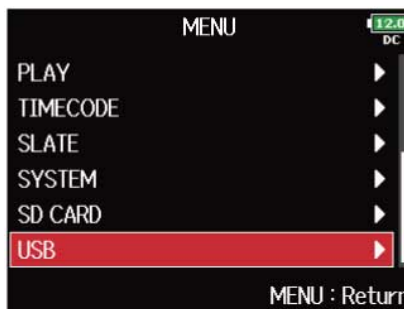

This opens the Menu Screen.

2. Use  to select "USB", and press .



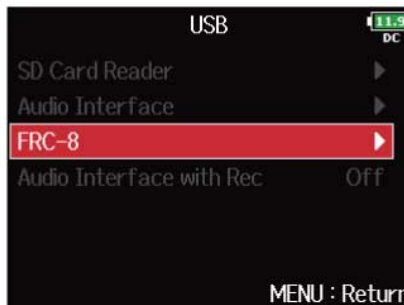

3. Use  to select "FRC-8", and press .

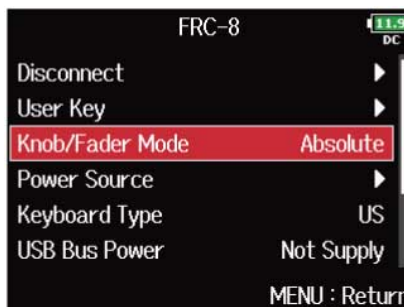

4. Use  to select "Knob/Fader Mode", and press .



5. Use  to select the FRC-8 fader and knob operation, and press .



| Setting | Explanation |
|----------|---|
| Absolute | When a knob or fader is operated, the parameter value will change to the value shown by that knob or fader. |
| Safety | When a knob or fader is operated, the parameter value will not change until the knob or fader first matches that value. |

NOTE:



The FRC-8 headphone volume operation cannot be changed.

Setting user keys for the FRC-8 (User Key)

You can assign functions to the FRC-8 user keys.

1. Press .

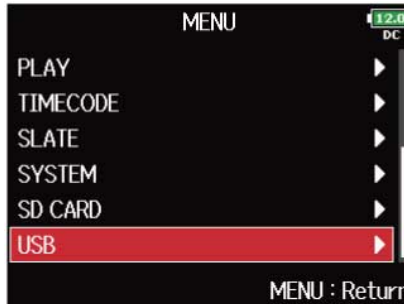

This opens the Menu Screen.

2. Use  to select "USB", and press .



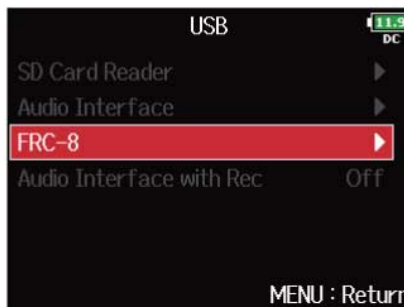

3. Use  to select "FRC-8", and press .



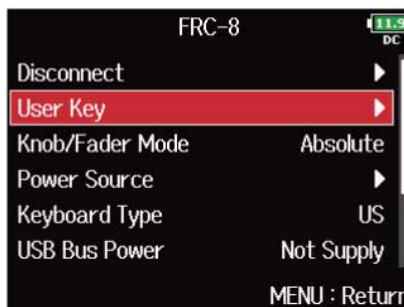

4. Use  to select "User Key", and press .

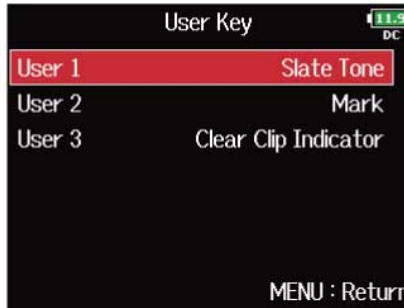

5. Use  to select the key to which to assign a function, and press .



6. Use  to select the function to assign, and press .



| Setting | Explanation |
|----------------------|--|
| None | No function is assigned. |
| Slate Mic | Enable and disable the slate mic. (→ Recording with the slate mic (Slate Mic)) |
| Slate Tone | Generate and stop slate tones. (→ Recording a slate tone (Slate Tone)) |
| Mark | Add marks to WAV format takes during recording and playback. |
| Set Trim Link | Open the Trim Link screen. (→ Adjusting the input levels of multiple tracks simultaneously (Trim Link)) |
| Hold | Use to disable the keys set with “Key Hold Target”. (→ Setting the keys held (Key Hold Target)) |
| Clear Clip Indicator | Clear the level meter clipping indicators. |
| Circled | Circle the currently selected take. (→ Setting the circling takes) |



Setting the power supply used by the FRC-8 (Power Source)

Set the DC power supply shutdown voltage, nominal voltage and type of batteries so that the remaining power supply charge can be shown accurately.

On this menu page, you can check the voltage of each power supply and the remaining battery capacity.

1. Press .

This opens the Menu Screen.

2. Use  to select "USB", and press .

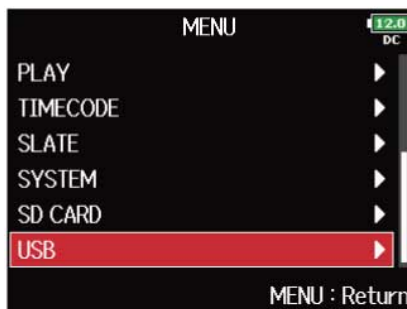

3. Use  to select "FRC-8", and press .

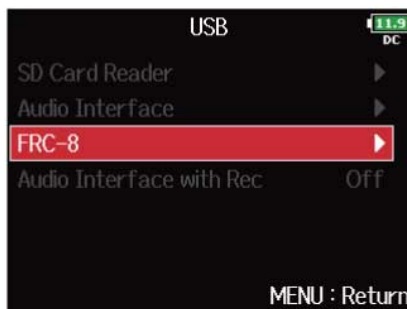

4. Use  to select "Power Source", and press .

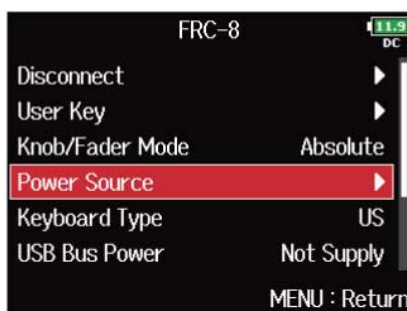

Power settings for the FRC-8 are the same as for the F8n Pro. See ["Setting the power supply used \(Power Source\)"](#).

NOTE:



- When multiple power supplies are connected, they will be used in the following order of priority.
DC power supply (Ext DC) > USB bus power (supplied by F8n Pro) > AA batteries (Int AA)
- The voltages of each power supply are shown on the display.

Powering the FRC-8 with USB bus power (USB Bus Power)

The F8n Pro can supply USB bus power to the FRC-8.

1. Press .

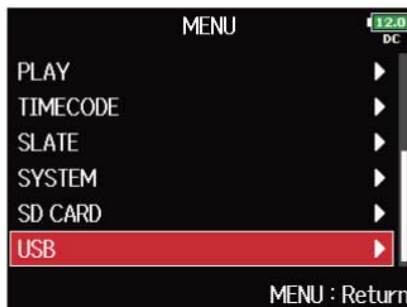

This opens the Menu Screen.

2. Use  to select "USB", and press .



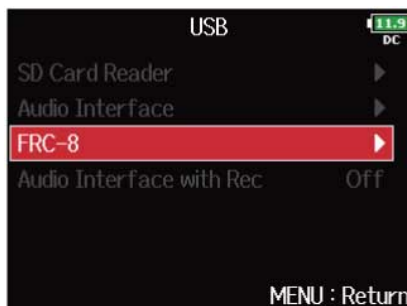

3. Use  to select "FRC-8", and press .

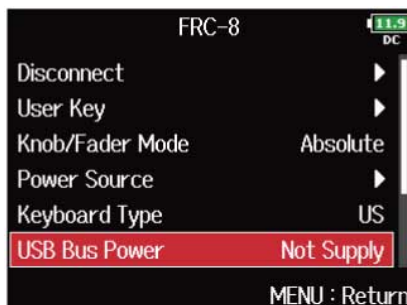

4. Use  to select "USB Bus Power", and press .



5. Use  to select "Supply to FRC-8", and press .

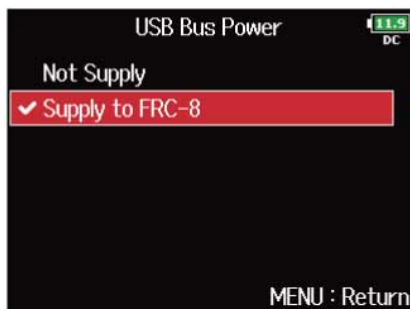

NOTE:



When the F8n Pro is supplying bus power, do not connect any device other than an FRC-8 to the USB port. Doing so could damage the and the connected device.

Setting the FRC-8 LED brightness (LED Brightness)

You can adjust the brightness of the LEDs on the FRC-8.

1. Press .

This opens the Menu Screen.

2. Use  to select "USB", and press .

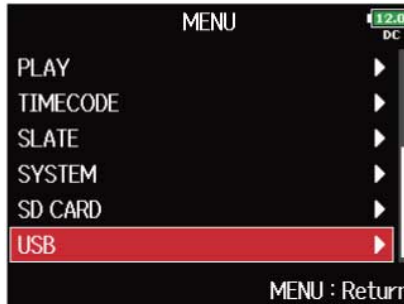

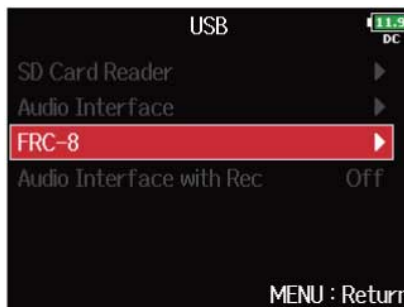

3. Use  to select "FRC-8", and press .



4. Use  to select "LED Brightness", and press .



5. Use  to adjust the brightness, and press  .



NOTE:

This can be set from 5 to 100.

Updating the FRC-8 firmware

You can check the FRC-8 firmware version and update it to the latest version.
The latest update file can be downloaded from the ZOOM website (www.zoom.co.jp).

1. See “[Using the FRC-8 as a controller \(Connect\)](#)”, and connect the F8n Pro and the FRC-8.

NOTE:

Updating is not possible if the remaining battery or DC power supply charge is low. In this case, replace the batteries with new ones or use a charged DC power supply.

2. Copy the update file to the root directory on an SD card.



3. Load the SD card into the SD CARD 1 slot. (→ [Loading SD cards](#))

NOTE:

If an SD card is loaded in the SD CARD 2 slot, eject it.

4. Press .

This opens the Menu Screen.

5. Use  to select “USB”, and press .

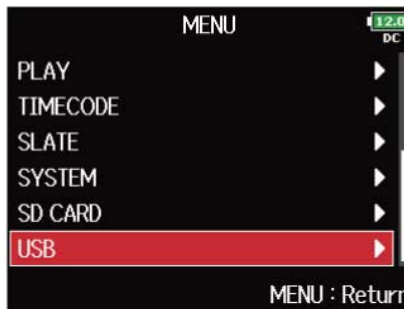

6. Use  to select “FRC-8”, and press .

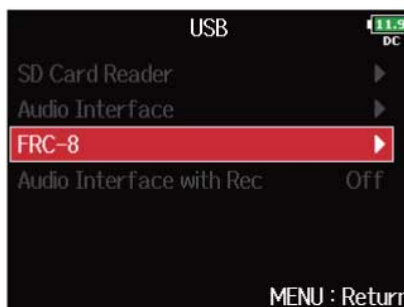

7. Use  to select "Firmware Version", and press .

This opens the screen for checking the firmware version.

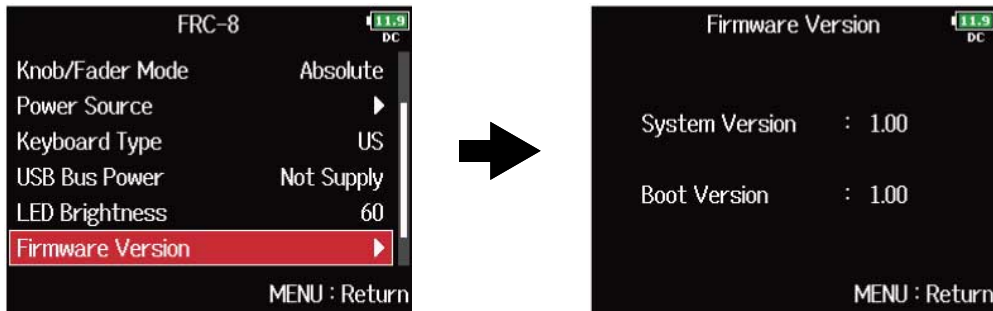



8. Press .

This returns to the previous screen.

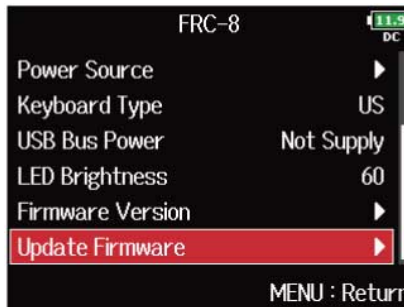
9. Use  to select "Update Firmware", and press .



10. Use  to select "Yes", and press .

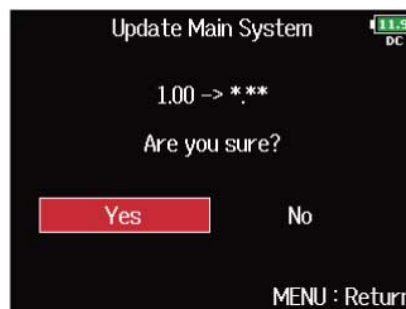

NOTE:

Do not turn the power off, remove an SD card or disconnect the USB cable during an update. Doing so could cause the FRC-8 to become unstartable.

11. When finished updating, turn the FRC-8 power off.



Controlling the F8n Pro from a smartphone/ tablet

You can operate the F8n Pro wirelessly from a smartphone or tablet using the dedicated F8 Control app.

- This function cannot be used with an F8n Pro after it is first shipped from the factory. To use this function, a software extension file must be downloaded from the ZOOM website (zoomcorp.com) and installed in the unit.
- The F8n Pro has received radio law certification in Japan, the USA, Canada and Europe (EU). Use of this function is not allowed in other countries and regions. Using it in countries where certification has not been received could result in legal penalties. ZOOM CORPORATION will not assume any responsibility related to penalties due to the use of this function.

NOTE:

- The dedicated F8 Control app must be installed on the smartphone/tablet beforehand. The F8 Control app can be downloaded from the App Store and Google play. For app setting and operation procedures, see the F8 Control app operation manual.
- The F8n Pro cannot be simultaneously connected to the F8 Control app and an UltraSync BLUE.



Making various settings

Setting how timecode is shown (Home Timecode Display Size)

You can change the size of the timecode display on the Home Screen.

1. Press .

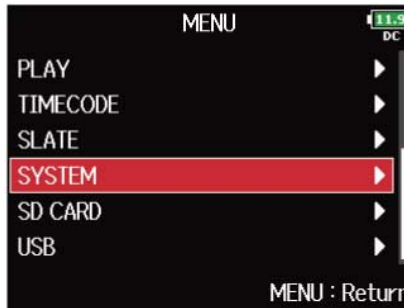

This opens the Menu Screen.

2. Use  to select "SYSTEM", and press .

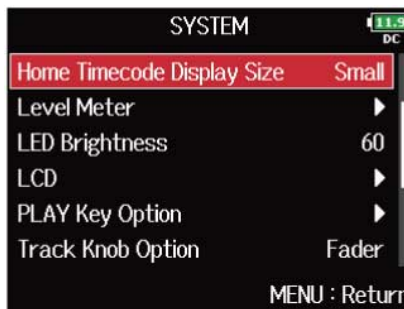

3. Use  to select "Home Timecode Display Size", and press .



4. Use  to select the size, and press .

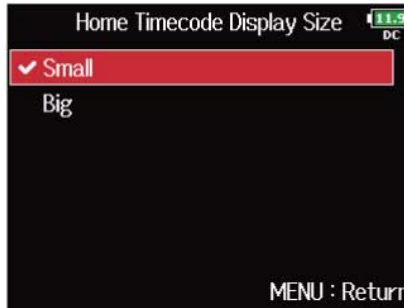

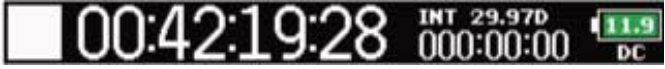

| Setting | Explanation |
|---------|--|
| Small | The timecode is small and the time counter is large.  |
| Big | The timecode is large and the time counter is small.  |

Setting level meter appearance (Level Meter)



You can set how the level meters appear on the display.

1. Press .

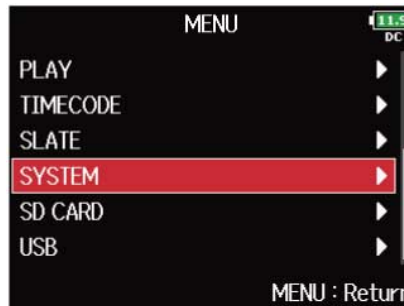

This opens the Menu Screen.

2. Use  to select "SYSTEM", and press .



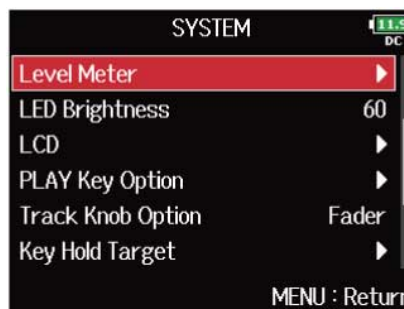





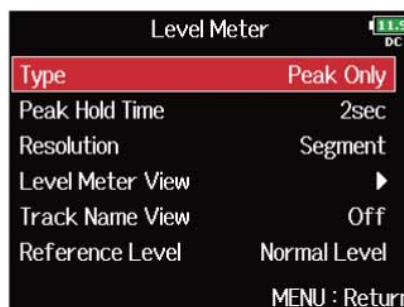

3. Use  to select "Level Meter", and press .











4. Use  to select a setting item, and press .



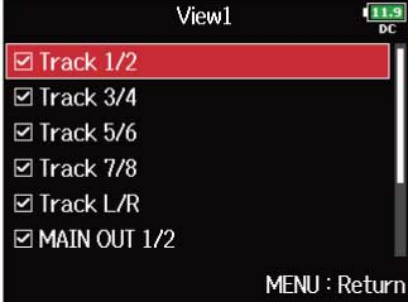

| Setting | Explanation |
|----------------|---|
| Type | <p>You can set whether the level meters use VU or Peak style.</p> <p>1. Use  to select the type, and press .</p> <div data-bbox="858 353 1267 658" style="border: 1px solid black; padding: 5px; margin: 10px 0;"> <p style="text-align: center;">Type 11.9 DC</p> <p>✓ Peak Only</p> <p>Peak + VU</p> <p>VU Only</p> <p style="text-align: right;">MENU : Return</p> </div> <ul style="list-style-type: none"> • Peak Only: The actual peak level of the signal (dBFS) is shown. <div data-bbox="719 775 1406 864" style="border: 1px solid black; padding: 5px; margin: 10px 0;"> </div> <ul style="list-style-type: none"> • Peak + VU: Both VU and peak level are shown simultaneously. In this mode, the bars function as a VU meter except for the rightmost bar, which shows the peak level. <div data-bbox="719 1070 1406 1160" style="border: 1px solid black; padding: 5px; margin: 10px 0;"> </div> <ul style="list-style-type: none"> • VU Only: This display style is close to human hearing. <div data-bbox="719 1276 1406 1366" style="border: 1px solid black; padding: 5px; margin: 10px 0;"> </div> |
| Peak Hold Time | <p>You can set the peak hold time.</p> <p>1. Use  to adjust the peak hold time, and press .</p> <div data-bbox="858 1547 1267 1852" style="border: 1px solid black; padding: 5px; margin: 10px 0;"> <p style="text-align: center;">Peak Hold Time 11.9 DC</p> <p>Off</p> <p>1sec</p> <p>✓ 2sec</p> <p>3sec</p> <p>4sec</p> <p>5sec</p> <p style="text-align: right;">MENU : Return</p> </div> |

| Setting | Explanation |
|------------|---|
| Resolution | <p>You can set the level meter resolution.</p> <p>1. Use  to select the resolution, and press .</p> <div data-bbox="858 349 1267 656" style="border: 1px solid black; background-color: black; padding: 5px; margin: 10px 0;"> <p style="text-align: right;">Resolution 11.9 DC</p> <p>✓ Segment</p> <p>Solid</p> <p style="text-align: right;">MENU : Return</p> </div> <ul style="list-style-type: none"> • Segment (Shown when set to VU Only) <div data-bbox="718 775 1406 864" style="border: 1px solid black; background-color: black; padding: 5px; margin: 10px 0;">  </div> <ul style="list-style-type: none"> • Solid (Shown when set to VU Only) <div data-bbox="718 981 1406 1070" style="border: 1px solid black; background-color: black; padding: 5px; margin: 10px 0;">  </div> |

| Setting | Explanation |
|------------------|--|
| Level Meter View | <p>You can set which tracks are shown on the Home Screen.</p> <p>1. Use  to select "View1" – "View4", and press .</p>  <p>2. Use  to select tracks to show, and press .</p>  <p>3. Press .</p> <hr/> <p>HINT:</p> <ul style="list-style-type: none"> • Multiple tracks can be shown. Not showing any tracks is also possible. • If none of the check boxes are checked, no track level meters will appear on the Home Screen. <hr/> |

| Setting | Explanation |
|-----------------|---|
| Track Name View | <p>Track names can be shown on level meters.</p> <p>1. Use  to select "On", and press .</p> <div data-bbox="858 349 1267 656" data-label="Image"> </div> <ul style="list-style-type: none"> • Off: The track names are not shown on the level meters. <div data-bbox="858 775 1267 1081" data-label="Image"> </div> <ul style="list-style-type: none"> • On: The track names set with the setting of "Changing the track name of the next take recorded (Track Name)" are shown on the level meters. <div data-bbox="858 1290 1267 1597" data-label="Image"> </div> |



| Setting | Explanation |
|-----------------|---|
| Reference Level | <p>You can set the level meter reference.</p> <p>1. Use  to select the reference level setting, and press .</p> <div data-bbox="858 353 1267 658" style="border: 1px solid black; padding: 5px; margin: 10px 0;"> <p style="text-align: center;">Reference Level 11.9 DC</p> <p>✓ Normal Level</p> <p>Low Level</p> <p style="text-align: right;">MENU : Return</p> </div> <p>■ When level meter type is “Peak Only”</p> <ul style="list-style-type: none"> • Normal Level: The center of the level meter is -12 dBFS. Clear monitoring of levels higher than -12 dBFS is possible. <div data-bbox="719 920 1406 1010" style="border: 1px solid black; padding: 2px; margin: 10px 0;"> </div> <ul style="list-style-type: none"> • Low Level: The center of the level meter is -20 dBFS. Clear monitoring of levels lower than -20 dBFS is possible. <div data-bbox="719 1167 1406 1256" style="border: 1px solid black; padding: 2px; margin: 10px 0;"> </div> <p>■ When level meter type is “Peak + VU” or “VU Only”</p> <ul style="list-style-type: none"> • Normal Level: The center of the level meter is 0 VU (-20 dBFS). Clear monitoring of levels higher than 0 VU (-20 dBFS) is possible. <div data-bbox="719 1518 1406 1608" style="border: 1px solid black; padding: 2px; margin: 10px 0;"> </div> <ul style="list-style-type: none"> • Low Level: The center of the level meter is -10 VU (-30 dBFS). Clear monitoring of levels lower than -10 VU (-30 dBFS) is possible. <div data-bbox="719 1771 1406 1861" style="border: 1px solid black; padding: 2px; margin: 10px 0;"> </div> |

Setting the LED brightness (LED Brightness)

You can adjust the brightness of the LED level meters on the front of the F8n Pro.

1. Press .

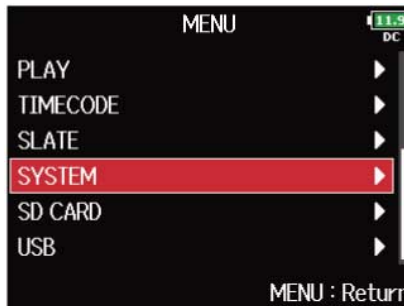

This opens the Menu Screen.

2. Use  to select "SYSTEM", and press .



3. Use  to select "LED Brightness", and press .



4. Use  to adjust the brightness, and press .



HINT:



This can be set from 5 to 100.

Making display settings (LCD)

You can make settings related to the display.

1. Press .

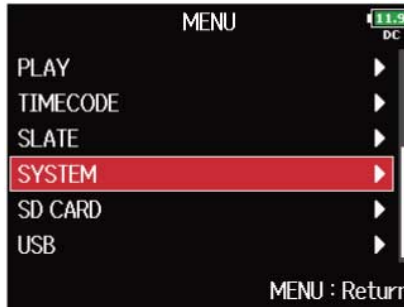

This opens the Menu Screen.

2. Use  to select "SYSTEM", and press .



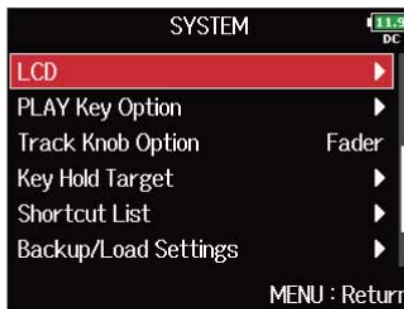





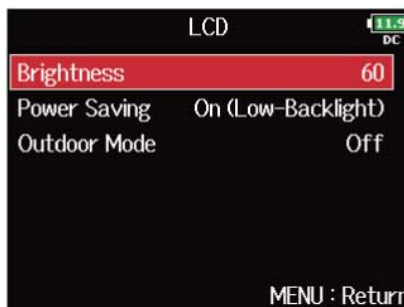

3. Use  to select "LCD", and press .



4. Use  to select a setting item, and press .



| Setting | Explanation |
|--------------|--|
| Brightness | <p>You can adjust the display brightness.</p> <p>1. Use  to adjust the brightness, and press .</p> <div data-bbox="858 353 1267 658" style="text-align: center;">  </div> <hr/> <p>HINT: This can be set from 5 to 100.</p> |
| Power Saving | <p>You can set the display backlight for power saving to dim after 30 seconds without use.</p> <p>1. Use  to select the setting, and press .</p> <div data-bbox="858 1014 1267 1319" style="text-align: center;">  </div> <ul style="list-style-type: none"> • Off: The backlight brightness does not change even after time passes without use. • On (Low-Backlight): The backlight dims after time without use. • On (Backlight-Off): The backlight turns off after time without use. <div data-bbox="596 1554 1487 1704" style="border: 1px solid black; padding: 5px;"> <p>NOTE: This function only activates when the F8n Pro is powered by internal batteries or an external DC power supply.</p> </div> |

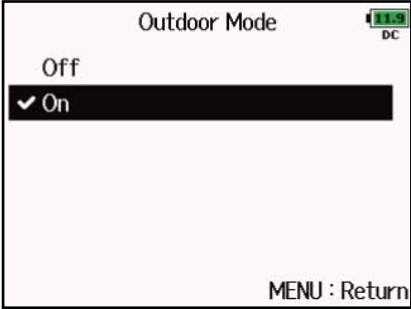

| Setting | Explanation |
|--------------|--|
| Outdoor Mode | <p>The display can be set to be easier to read in bright environments including in sunlight.</p> <p>1. Use  to select "On", and press .</p>  <p>The screenshot shows a menu titled "Outdoor Mode" with two options: "Off" and "On". The "On" option is highlighted with a black bar and a checkmark. The menu also displays "MENU : Return" at the bottom right.</p> |

Adding marks when recording/playing (PLAY Key Option)

You can set how marks are added when  is pressed while recording or playing back a WAV format file.

1. Press .

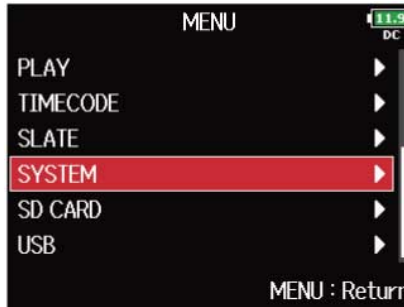

This opens the Menu Screen.

2. Use  to select "SYSTEM", and press .









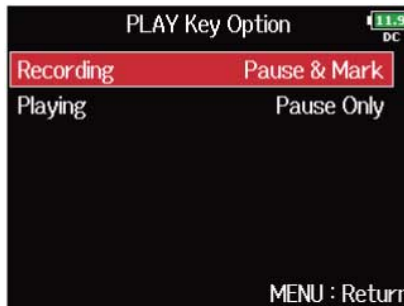



3. Use  to select "PLAY Key Option", and press .





4. Use  to select a setting item, and press .





| Setting | Explanation |
|-----------|---|
| Recording | <p>You can set how marks are added when recording.</p> <p>1. Use  to select how marks are added, and press .</p> <div data-bbox="858 353 1267 658" style="border: 1px solid black; background-color: black; color: white; padding: 5px; margin: 10px auto; width: fit-content;"> <p style="text-align: right;">11.9 DC</p> <p style="text-align: center;">Recording</p> <p>Pause Only</p> <p style="background-color: red; color: white; padding: 2px;">✓ Pause & Mark</p> <p>Mark Only</p> <p style="text-align: right;">MENU : Return</p> </div> <ul style="list-style-type: none"> • Pause Only: Pressing  will pause without adding a mark. • Pause & Mark: Pressing  will pause and add a mark. • Mark Only: Pressing  will add a mark without pausing. |
| Playing | <p>You can set how marks are added when playing.</p> <p>1. Use  to select how marks are added, and press .</p> <div data-bbox="858 1039 1267 1344" style="border: 1px solid black; background-color: black; color: white; padding: 5px; margin: 10px auto; width: fit-content;"> <p style="text-align: right;">11.9 DC</p> <p style="text-align: center;">Playing</p> <p style="background-color: red; color: white; padding: 2px;">✓ Pause Only</p> <p>Pause & Mark</p> <p>Mark Only</p> <p style="text-align: right;">MENU : Return</p> </div> <ul style="list-style-type: none"> • Pause Only: Pressing  will pause without adding a mark. • Pause & Mark: Pressing  will pause and add a mark. • Mark Only: Pressing  will add a mark without pausing. |

Setting the keys held (Key Hold Target)



Use the hold function to prevent misoperation during recording. Press  +  to turn it on/off. Follow these instructions to set which keys are disabled by the hold function.

1. Press .

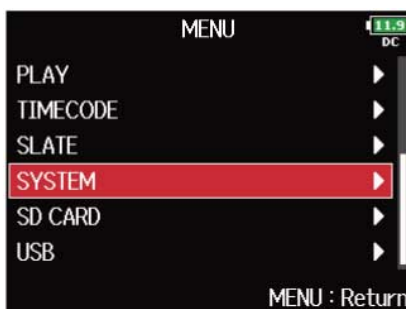

This opens the Menu Screen.

2. Use  to select "SYSTEM", and press .

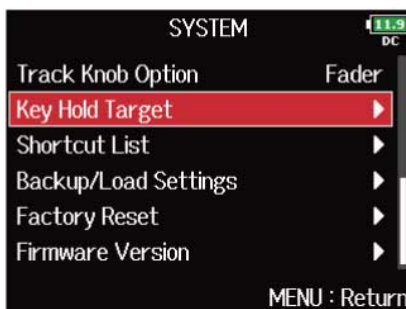

3. Use  to select "Key Hold Target", and press .



4. Use  to select the keys held, and press .

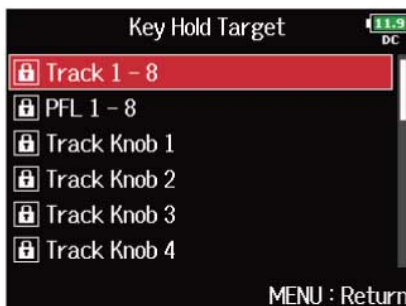



HINT:

You can select "Track 1-8", "PFL 1-8", "Trim Knob 1-8", "Slate Mic", "Slate Tone", "Encoder", "MENU", "HP Volume", "REW", "STOP", "FF", "PLAY" and "REC".

5. Press  .

HINT:



- Even when hold is on for “STOP” and “Track1-8”, you can press  +  to turn the hold function off.
 - Operation using the FRC-8 and F8 Control is possible even when the hold function is on.
-

Setting the date and time (Date/Time (RTC))

The date and time set on the F8n Pro are used when recording files, for example. You can also set the date format (order of year, month and day).

1. Press .

This opens the Menu Screen.

2. Use  to select "SYSTEM", and press .

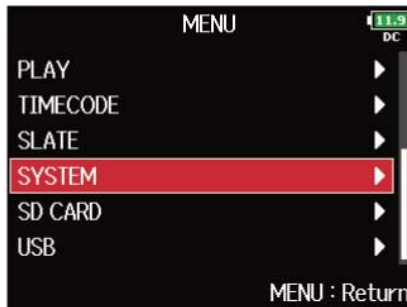

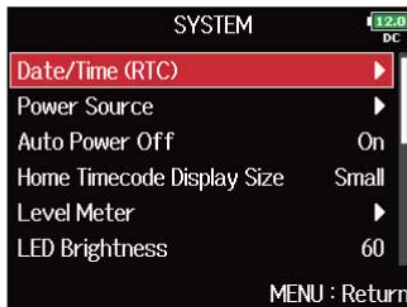

3. Use  to select "Date/Time(RTC)", and press .



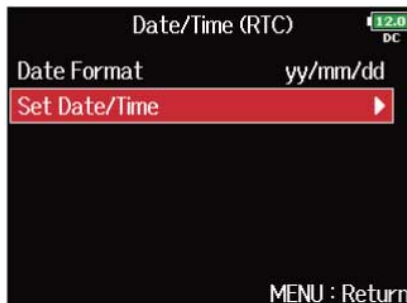

4. Use  to select "Set Date/Time", and press .



5. Use  to select a setting item and press .



6. Use  to change the value and press .



7. Repeat steps 5 and 6 to set the date and time.

8. After finishing all settings, use  to select "Enter" and press .



NOTE:





If power is not supplied by an AC adapter for a long time, date and time settings will be reset. If the date and time setting screen appears during startup, set them again.

HINT:

This screen opens automatically the first time the power is turned on after purchase.

Setting the date format:

The date format added to recording files can be changed.

1. In step 4, use  to select "Date Format", and press .
2. Use  to select the format, and press .

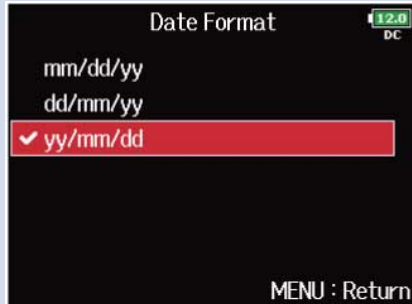

- mm/dd/yy: Month, day, year order
- dd/mm/yy: Day, month, year order
- yy/mm/dd: Year, month, day order



Disabling the Automatic Power Saving function (Auto Power Off)

The power will automatically turn off if the F8n Pro is unused for 10 hours.



If you want the power to stay on continuously until powered off, disable the Automatic Power Saving function.

1. Press .

This opens the Menu Screen.

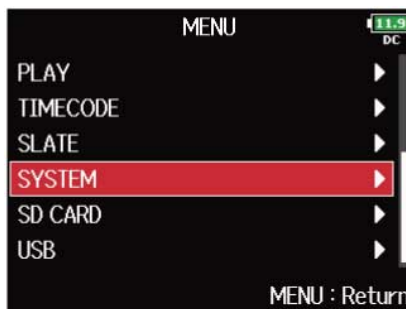
2. Use  to select "SYSTEM", and press .



3. Use  to select "Auto Power Off", and press .

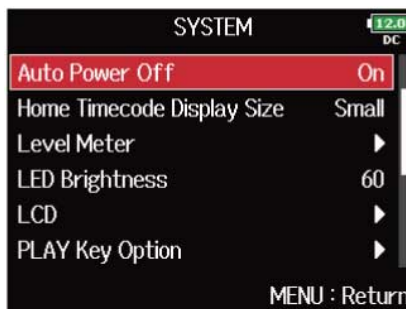

4. Use  to select "Off", and press .

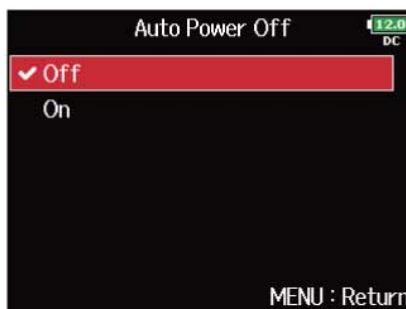

NOTE:

The power will not turn off automatically regardless of the Automatic Power Saving setting in the following cases:

- When recording/playing
- When the F8n Pro is used as an audio interface
- When the F8n Pro is used as a card reader
- When an SD card is being tested
- When timecode is being calibrated
- When the firmware is being updated



Setting the power supply used (Power Source)

Set the external DC power supply shutdown voltage, nominal voltage and type of batteries so that the remaining power supply charge can be shown accurately.

On this menu page, you can also check the voltage of each power supply and the remaining battery capacity.

1. Press .

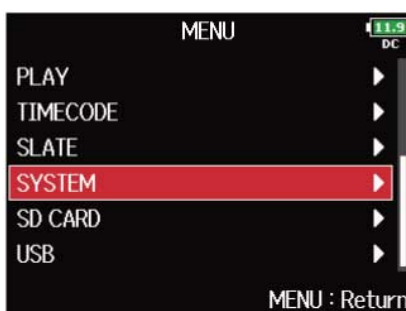

This opens the Menu Screen.

2. Use  to select "SYSTEM", and press .



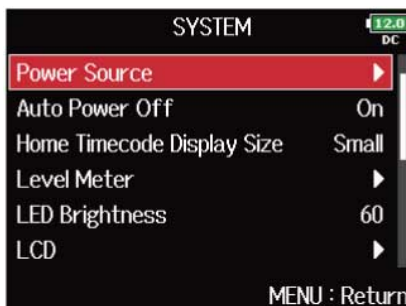



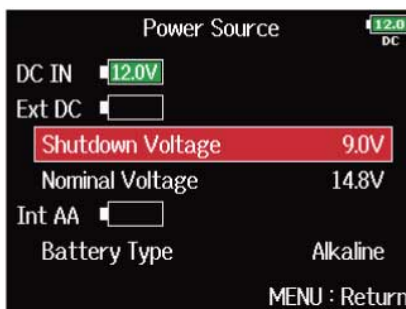

3. Use  to select "Power Source", and press .



4. Use  to select a setting item, and press .



| Setting | Explanation |
|------------------|---|
| Shutdown Voltage | <p>You can set the external DC power supply (EXT DC) shutdown voltage. When an external DC power supply is being used, if the voltage drops below the value set here, the F8n Pro will automatically stop recording and turn off. If AA batteries (Int AA) are installed, however, the power supply will switch to Int AA and operation will continue.</p> <p>1. Use  to select the voltage, and press .</p> <div data-bbox="858 528 1267 831" style="border: 1px solid black; padding: 5px; margin: 10px auto; width: fit-content;"> <p style="text-align: center;">Shutdown Voltage 12.0 DC</p> <p style="text-align: center; background-color: red; color: white; padding: 2px;">9.0V ↑ ↓</p> <p style="text-align: right;">MENU : Return</p> </div> <hr style="border: 0.5px solid blue;"/> <p>HINT:</p> <ul style="list-style-type: none"> • The shutdown voltage is the voltage when the external DC power supply runs out and can no longer supply power. • See the manual for the external DC power supply for the shutdown voltage value. |
| Nominal Voltage | <p>You can set DC power supply (Ext DC) nominal voltage.</p> <p>1. Use  to select the voltage, and press .</p> <div data-bbox="858 1294 1267 1597" style="border: 1px solid black; padding: 5px; margin: 10px auto; width: fit-content;"> <p style="text-align: center;">Nominal Voltage 12.0 DC</p> <p style="text-align: center; background-color: red; color: white; padding: 2px;">14.8V ↑ ↓</p> <p style="text-align: right;">MENU : Return</p> </div> <hr style="border: 0.5px solid blue;"/> <p>HINT:</p> <ul style="list-style-type: none"> • The nominal voltage is the voltage of the external DC power supply under normal conditions. This value should be indicated on the outside of the external DC power supply. • This can be set from 12.0 to 15.0 V in 0.2 V intervals. |

| Setting | Explanation |
|--------------|--|
| Battery Type | <p>You can set the AA battery type (Int AA).</p> <p>1. Use  to select the type, and press .</p> <div data-bbox="858 353 1267 658" style="border: 1px solid black; padding: 5px; margin: 10px auto; width: fit-content;"> <p style="text-align: center;">Battery Type 12.0 DC</p> <p>✓ Alkaline</p> <p>Ni-MH</p> <p>Lithium</p> <p style="text-align: right;">MENU : Return</p> </div> <ul style="list-style-type: none"> • Alkaline: Alkaline batteries • Ni-MH: Nickel-metal hydride batteries • Lithium: Lithium batteries |

NOTE:

- When multiple power supplies are connected, they will be used in the following order of priority.
AC adapter (DC IN) > DC power supply (Ext DC) > AA batteries (Int AA)
- The voltages of each power supply are shown on the display.

Backing up and loading F8n Pro settings (Backup/Load Settings)



F8n Pro settings can be backed up to and loaded from SD cards.

Backing up



This saves a backup file to the "F8n Pro_SETTINGS" folder in the root directory of the SD card.

1. Press .

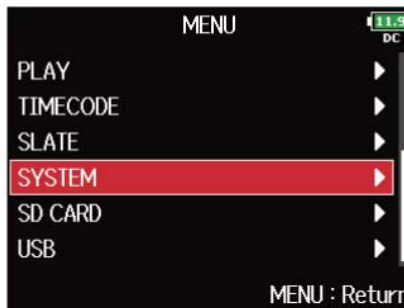

This opens the Menu Screen.

2. Use  to select "SYSTEM", and press .



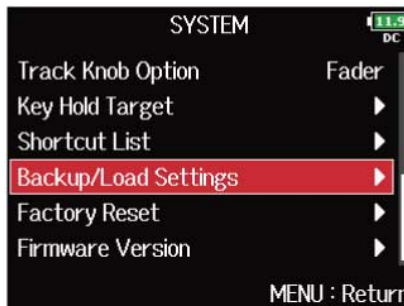

3. Use  to select "Backup/Load Settings", and press .

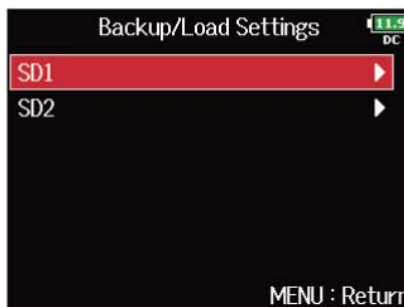

4. Use  to select the SD card to use for backup, and press .



5. Use  to select "Backup", and press .

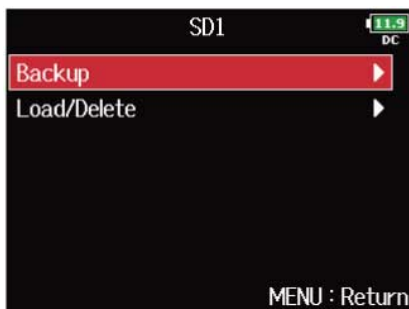

6. Edit the name of the file saved.

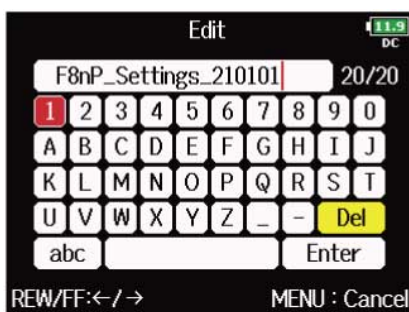

See "[Character input screen](#)" for how to input characters.

NOTE:



The extension of the saved backup file is ".ZSF".

Loading



You can load a backup file that is saved in the "F8n Pro_SETTINGS" folder in the root directory of the SD card.

1. Press .

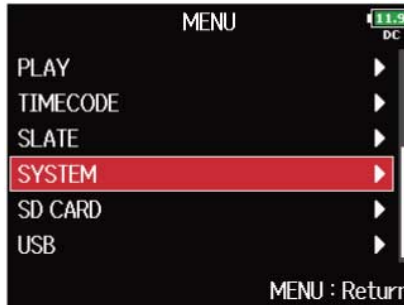

This opens the Menu Screen.

2. Use  to select "SYSTEM", and press .



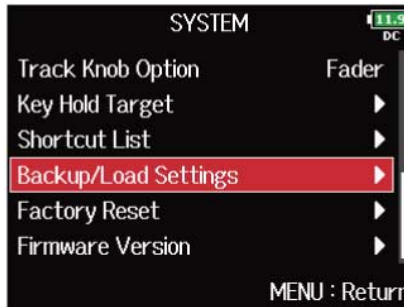

3. Use  to select "Backup/Load Settings", and press .



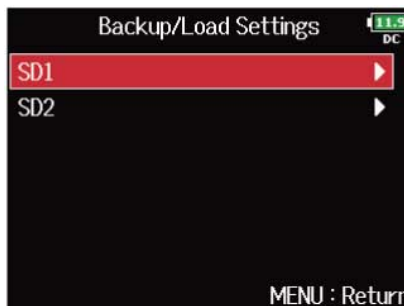

4. Use  to select the SD card to use for loading, and press .

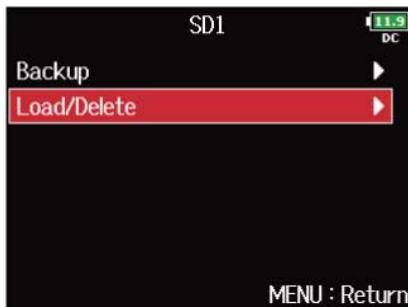

5. Use  to select "Load/Delete", and press .



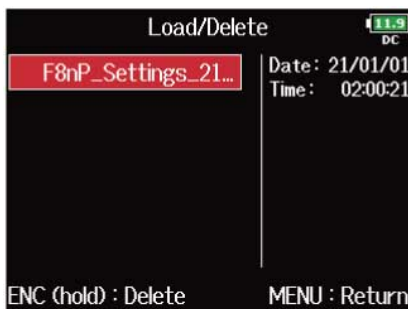

6. Use  to select the file to load, and press .



HINT:

You can press and hold  to delete a file.
Deleting a file will completely erase its data.

7. Use  to select "Yes", and press .





Restoring factory default settings



The F8n Pro can be restored to factory default settings.

1. Press .

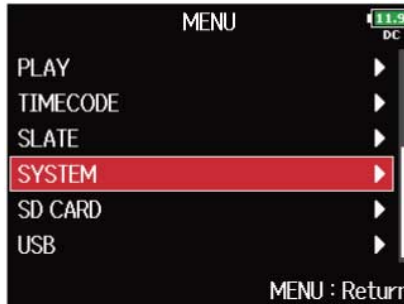

This opens the Menu Screen.

2. Use  to select "SYSTEM", and press .

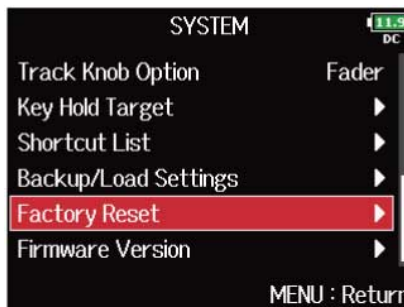

3. Use  to select "Factory Reset", and press .



4. Use  to select "Yes", and press .



After the F8n Pro is restored to its factory default settings, the power will turn off.

NOTE:

Conducting a factory reset will overwrite all settings to their factory defaults. Be certain before using this function.



Managing SD cards

Checking SD card information (Information)



You can check the size and free space of SD cards.

1. Press .

This opens the Menu Screen.

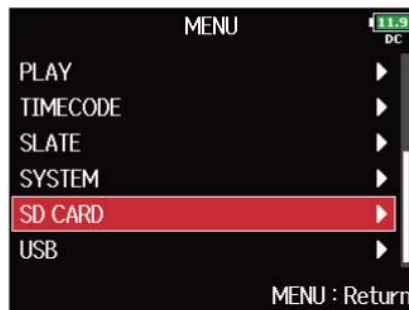
2. Use  to select "SD CARD", and press .



3. Use  to select "Information", and press .

SD card information is displayed.

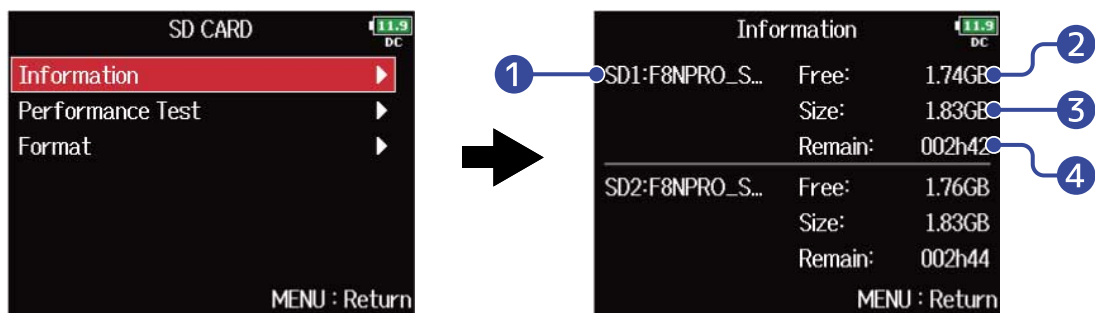

- 1 Volume label
- 2 Free space
- 3 Size
- 4 Remaining recordable time

Testing SD card performance (Performance Test)



You can test whether an SD card can be used with the F8n Pro.

A basic test can be done quickly, while a full test examines the entire SD card.



Conducting a quick test

1. Press .

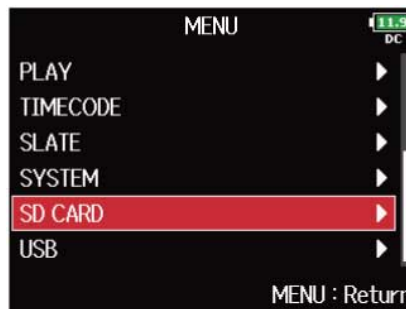

This opens the Menu Screen.

2. Use  to select "SD CARD", and press .



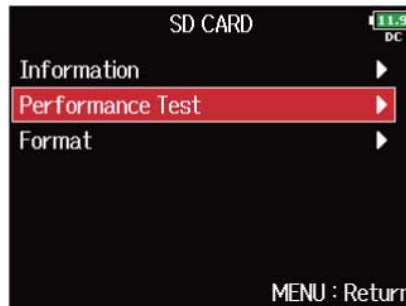

3. Use  to select "Performance Test", and press .



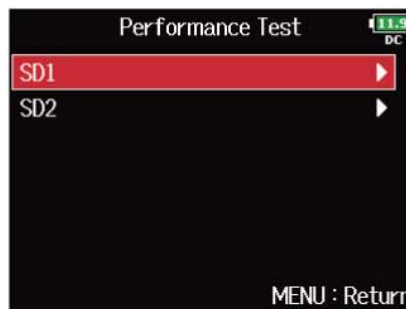

4. Use  to select the SD card to test, and press .

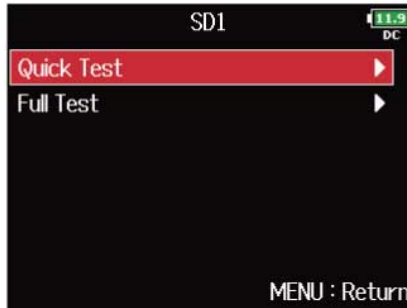

5. Use  to select "Quick Test", and press .



6. Use  to select "Yes", and press .

The card performance test will start. The test should take about 30 seconds.

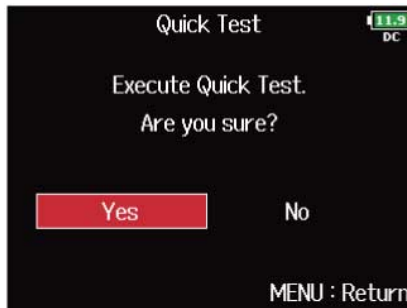

The result of the test will be shown when it completes.

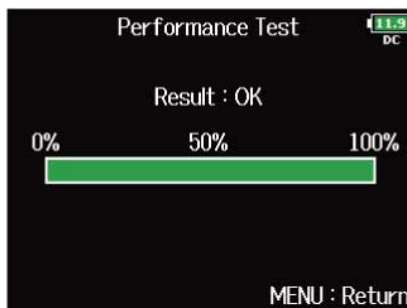

NOTE:

Even if a performance test result is "OK", there is no guarantee that writing errors will not occur. This information is just to provide guidance.

HINT:

You can cancel a test in progress by pressing .



Conducting a full test

1. Press .

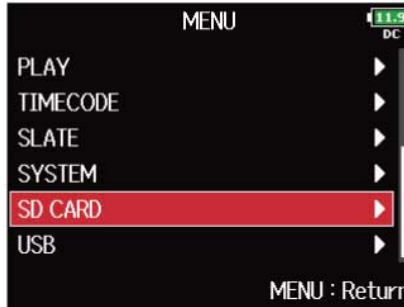

This opens the Menu Screen.

2. Use  to select "SD CARD", and press .

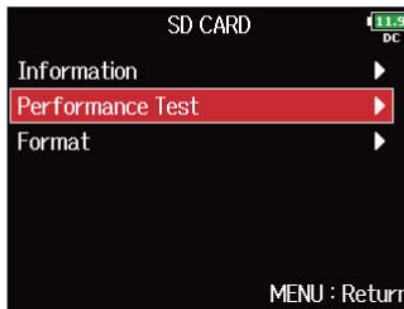

3. Use  to select "Performance Test", and press .



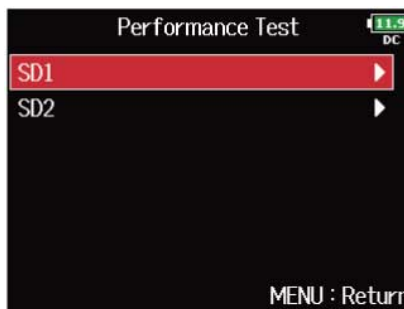

4. Use  to select the SD card to test, and press .

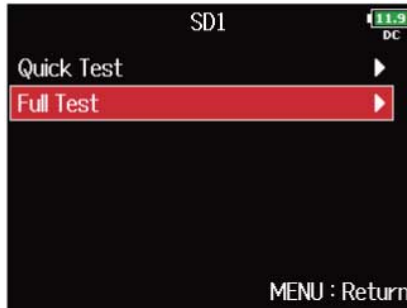

5. Use  to select "Full Test", and press .



6. Use  to select "Yes", and press .

The amount of time required for the full test will be shown.

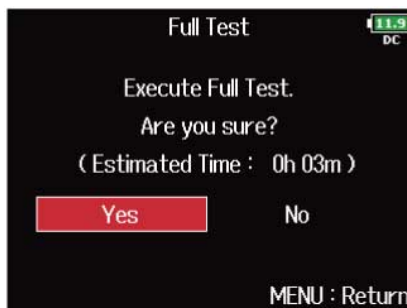

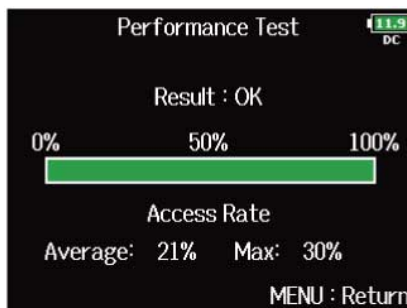

The result of the evaluation will be shown. If the access rate MAX reaches 100%, the card will fail (NG).



NOTE:

Even if a performance test result is "OK", there is no guarantee that writing errors will not occur. This information is just to provide guidance.

HINT:



- You can cancel a test in progress by pressing .
- You can press  to pause and resume the test.

Formatting SD cards (Format)



SD cards must be formatted for use with the F8n Pro.

1. Press .

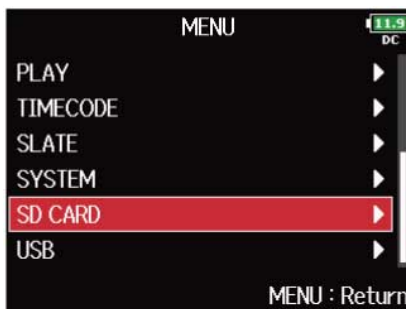

This opens the Menu Screen.

2. Use  to select "SD CARD", and press .



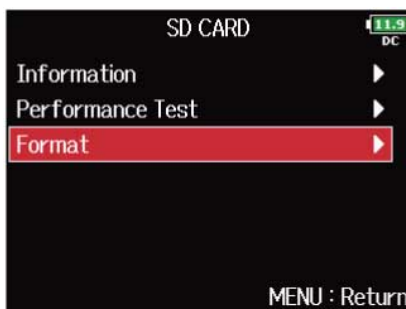

3. Use  to select "Format", and press .

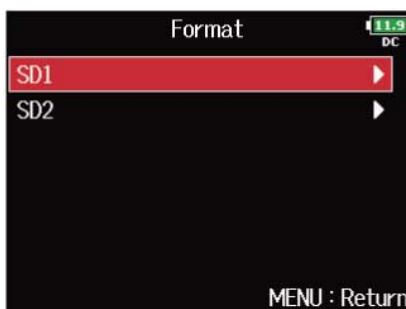

4. Use  to select the card to initialize, and press .



5. Use  to select "Yes", and press .



This formats the SD card.

NOTE:

- Before using SD cards that have just been purchased or that have been formatted by a computer, they must be formatted by the F8n Pro.
- Be aware that all data previously saved on an SD card will be deleted when it is formatted.



Managing the firmware

Checking the firmware versions



You can check the firmware version.

1. Press .

This opens the Menu Screen.

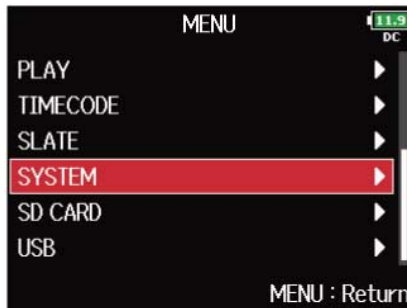
2. Use  to select "SYSTEM", and press .



3. Use  to select "Firmware Version", and press .

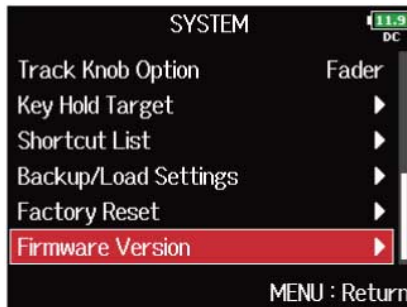

This shows the firmware versions.



Updating the firmware

The F8n Pro firmware can be updated to the latest versions.

The latest update file can be downloaded from the ZOOM website (zoomcorp.com).

Follow the instructions in the “F8n Pro Firmware Update Guide” on the F8n Pro download page.



About the F8n Pro Shortcut function

Checking the F8n Pro Shortcut function (Shortcut List)



The F8n Pro has a shortcut feature that allows quick access to various functions. See the "[List of shortcuts](#)" for information about the shortcut functions.

1. Press .

This opens the Menu Screen.

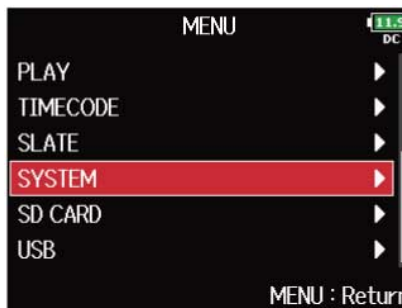
2. Use  to select "SYSTEM", and press .



3. Use  to select "Shortcut List", and press .

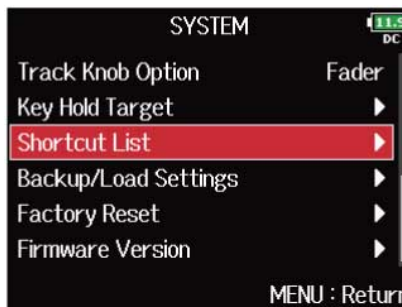



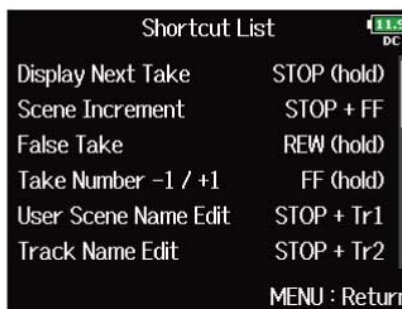

This opens the F8n Pro Shortcut List.



List of shortcuts

■ Home Screen





| Shortcut | Explanation |
|--|---|
| Press and hold  | Show the name that will be given to the next take recorded. Example: Scene001-T002 |
|  +  | Advance the scene number by 1 (when the Home Screen is open). |
| Press and hold  | Move the previously recorded take to the FALSE TAKE folder (when the Home Screen is open). |
| Press and hold  | The number given to the next recorded take can be increased or decreased by one when the Home Screen is open. |
|  + 1 | Open the "User Scene Name" screen. (→ Changing scene names) |
|  + 2 | Open the "Track Name" screen. (→ Changing the track name of the next take recorded (Track Name)) During recording, the  key does not need to be used. |
|  + 3 | Open the "Trim Link" screen. (→ Adjusting the input levels of multiple tracks simultaneously (Trim Link)) During recording, the  key does not need to be used. |
|  + 4 | Open the "Note" screen. (→ Changing the note for the next take recorded (Note)) During recording, the  key does not need to be used. |
|  + 5 | Clear the level meter clipping indicators. During recording, the  key does not need to be used. |
|  + 6 | Open the L/R track fader settings screen. During recording, the  key does not need to be used. |
|  + 7 | Open the "Headphone Routing" screen. (→ Setting signals sent to headphones (Headphone Routing)) During recording, the  key does not need to be used. |
|  + 8 | Use to disable the keys set with "Key Hold Target". (→ Setting the keys held (Key Hold Target)) During recording, the  key does not need to be used. |
|  + PFL (Track 1) | Circle the currently selected take. (→ Setting the circling takes) |

| Shortcut | Explanation |
|---|---|
|  +  (Track 2) | Open the “Timecode” screen. (→ Setting timecode functions) |

■ Mixer Screen

| Shortcut | Explanation |
|--|---|
| Press and hold  | Reset the selected pan/fader to the default value (when the Home Screen mixer is open). If already set to its default value, selecting a fader mutes the track. |

■ Character input screen

| Shortcut | Explanation |
|--|--|
| Press and turn  | Move the cursor vertically on a character input screen keyboard. |
|  +  | Delete a character on the character input screen. |
|  +  | Move the cursor to “Enter” on the character input screen keyboard. |

■ Routing screen

| Shortcut | Explanation |
|--|-----------------------------|
| Press and turn  | Move the cursor vertically. |

Appendix

Troubleshooting

If you think that the F8n Pro is operating strangely, check the following items first.

Recording/playback trouble

There is no sound or output is very quiet

- Check the connections to your monitoring system and its volume setting.
- Confirm that the volume of the F8n Pro is not too low. (→ [Adjusting the input signal monitoring balance](#))

Sound from connected equipment or inputs cannot be heard or is very quiet

- If you are using a mic capsule, confirm that it is oriented correctly.
- Check the input level settings. (→ [Adjusting input levels](#))
- If a CD player or other device is connected to an input jack, raise the output level of that device.
- Check the input signal monitoring settings. (→ [Adjusting the input signal monitoring balance](#), [Monitoring the input signals of specific tracks \(PFL/SOLO\)](#))
- Check the phantom power and plug-in power settings. (→ [Changing the phantom power settings \(Phantom\)](#), [Changing the plugin power setting \(Plugin Power\)](#))
- Check the headphone, MAIN OUT 1/2 and SUB OUT 1/2 routing. (→ [Setting signals sent to headphones \(Headphone Routing\)](#), [Selecting signals sent to the main outputs \(MAIN OUT Routing\)](#), [Selecting signals sent to the sub outputs \(SUB OUT Routing\)](#))

Recording not possible

- Confirm that track keys are lit red.
- Confirm that the SD card has free space. (→ [Checking SD card information \(Information\)](#))
- Confirm that an SD card is loaded properly in a card slot. (→ [Loading SD cards](#))
- If "Card Protected!" appears on the display, the SD card write-protection is enabled. Slide the lock switch on the SD card to disable write-protection.

Recorded sound cannot be heard or is very quiet

- Confirm that the volume levels of the tracks are not too low. (→ [Mixing takes](#))
- Confirm that track keys are lit green during playback.

Other trouble

Computer does not recognize it even though it is connected to a USB port

- The operation mode must be set on the F8n Pro to allow the computer to recognize the F8n Pro. (→ [Using as an audio interface \(Audio Interface\)](#))

Battery operation time is short

Making the following settings could increase the battery operation time.

- Set the power supply used correctly. (→ [Setting the power supply used \(Power Source\)](#))
- Turn unnecessary tracks off. (→ [Selecting inputs](#))
- Turn unnecessary outputs off. (→ [Disabling outputs \(Output On/Off\)](#))
- Set the phantom power voltage to 24V. (→ [Setting the voltage](#))
- Disable phantom power during playback. (→ [Disabling phantom power during playback](#))
- Turn timecode off if not using it. (→ [Setting the mode](#))
- Reduce the LED brightness. (→ [Setting the LED brightness \(LED Brightness\)](#))
- Reduce the display brightness. (→ [Making display settings \(LCD\)](#))
- Set the display to dim when not used for some time. (→ [Making display settings \(LCD\)](#))
- Reduce the sampling rate used to record files. (→ [Setting the sampling rate \(Sample Rate\)](#))
- Due to their characteristics, using nickel metal hydride batteries (especially high-capacity ones) or lithium batteries should enable longer use than alkaline batteries when power consumption is high.

Detailed product diagrams

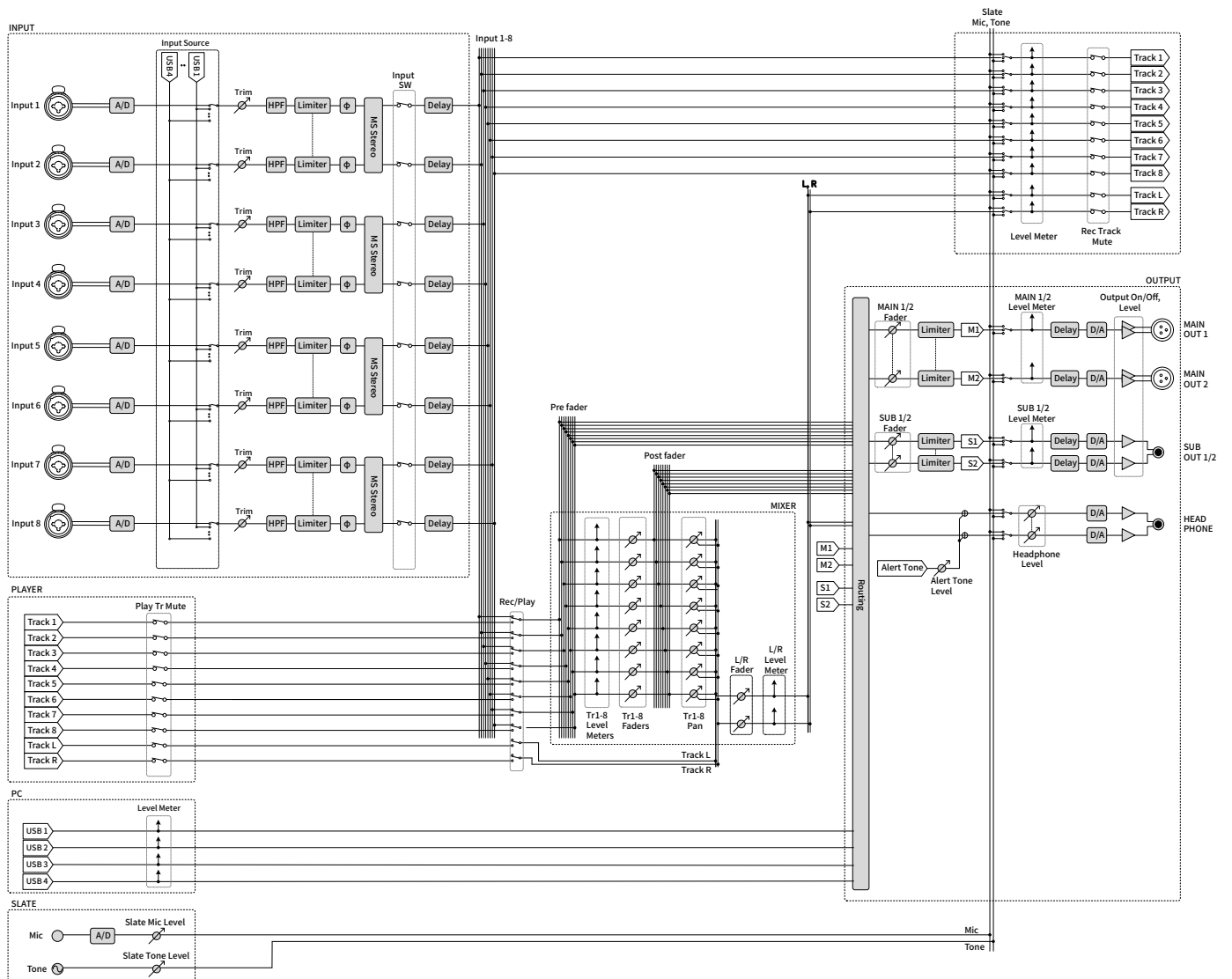

Routing

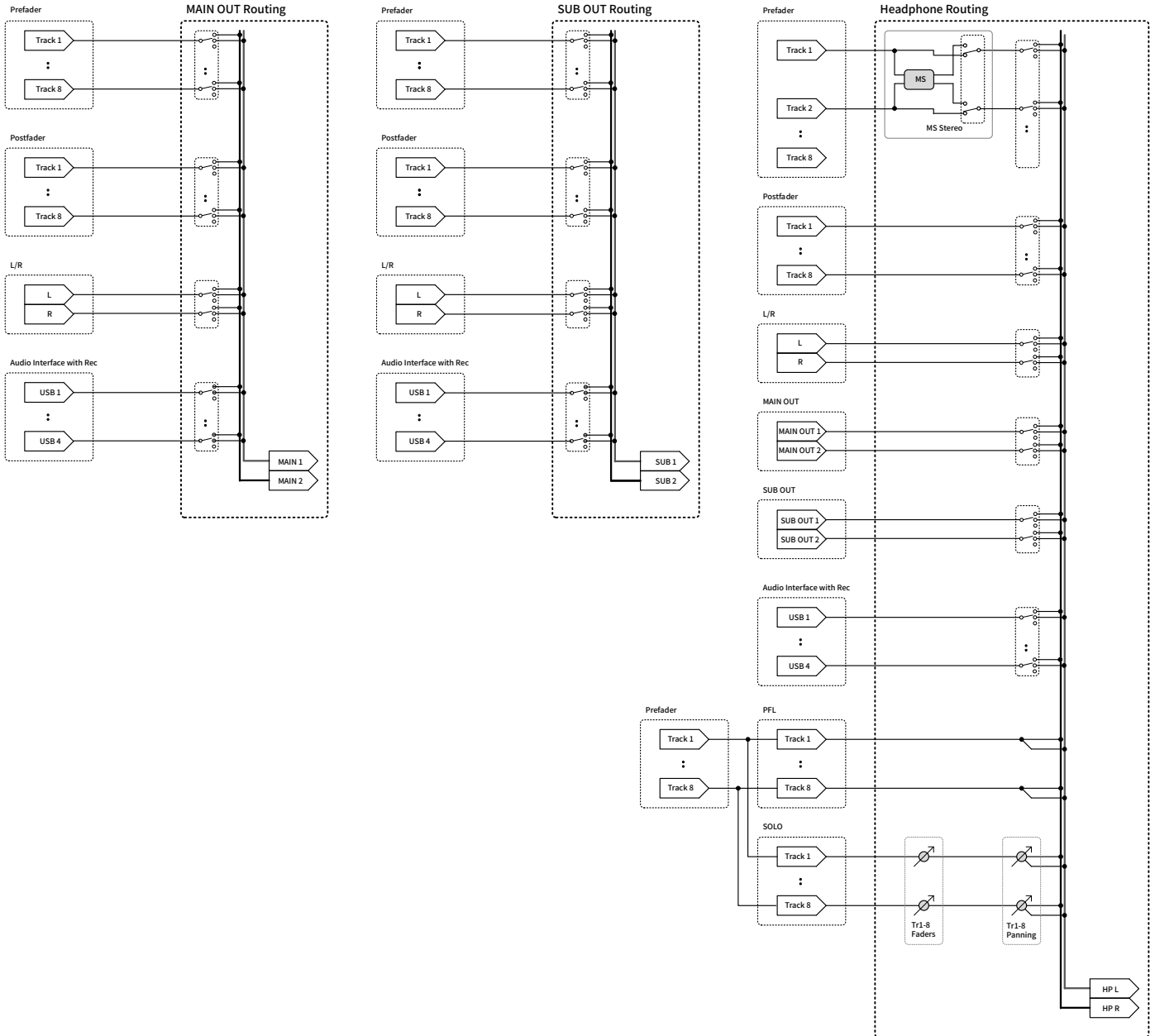

Metadata list

Metadata contained in BEXT chunks in WAV files

| Tag | Explanation | Remarks |
|----------|--------------------------------------|--|
| SPEED= | Frame rate | MENU > TIMECODE > Timecode > FPS |
| TAKE= | Take number | |
| UBITS= | User bits | MENU > TIMECODE > Timecode > Ubits |
| SCENE= | Scene name | MENU > META DATA (for Next Take) > Scene Name Mode MENU > META DATA (for Next Take) > User Scene Name MENU > FINDER > Option > Meta Data Edit > Scene MENU > FINDER > Option > Rename |
| TAPE= | Name of recording destination folder | MENU > FINDER (Recording destination folder name) MENU > FINDER > Option > Meta Data Edit > Folder(Tape) Name |
| CIRCLED= | Circled take | MENU > FINDER > Option > Meta Data Edit > Circle |
| TRL= | Left track name | Track names are written as follows. TRL=TrL, TRR=TrR, TR1=Tr1, TR2=Tr2, ... TR8=Tr8 |
| TRR= | Right track name | |
| TR1= | Track 1 name | |
| TR2= | Track 2 name | |
| TR3= | Track 3 name | |
| TR4= | Track 4 name | |
| TR5= | Track 5 name | |
| TR6= | Track 6 name | |
| TR7= | Track 7 name | |
| TR8= | Track 8 name | |
| NOTE= | Take note | MENU > META DATA (for Next Take) > Note MENU > FINDER > Option > Meta Data Edit > Note |

Metadata contained in iXML chunks in WAV files

○ = YES × = NO

| iXML master tag | iXML sub tag | Written | Read | Remarks |
|-----------------|--------------|---------|------|--|
| <PROJECT> | | ○ | ○ | MENU > FINDER (SD card root folder) MENU > FINDER > Option > Meta Data Edit > Project Name |
| <SCENE> | | ○ | ○ | MENU > META DATA (for Next Take) > Scene Name Mode MENU > META DATA (for Next Take) > User Scene Name MENU > FINDER > Option > Meta Data Edit > Scene MENU > FINDER > Option > Rename |
| <TAKE> | | ○ | ○ | MENU > FINDER > Option > Meta Data Edit > Take MENU > FINDER > Option > Rename |
| <TAPE> | | ○ | ○ | MENU > FINDER (recording destination folder name) MENU > FINDER > Option > Meta Data Edit > Folder(Tape) Name |
| <CIRCLED> | | ○ | ○ | MENU > FINDER > Option > Meta Data Edit > Circle |
| <WILD TRACK> | | × | × | |
| <FALSE START> | | × | × | |
| <NO GOOD> | | × | × | |
| <FILE UID> | | ○ | × | |
| <UBITS> | | ○ | × | MENU > TIMECODE > Timecode > Ubits |
| <NOTE> | | ○ | ○ | MENU > META DATA (for Next Take) > Note MENU > FINDER > Option > Meta Data Edit > Note |
| <BEXT> | | × | × | |
| <USER> | | × | × | |

| iXML master tag | iXML sub tag | Written | Read | Remarks |
|-----------------|---------------------------------------|---------|------|----------------------------------|
| <SPEED> | | | | |
| <SPEED> | <NOTE> | ○ | × | |
| <SPEED> | <MASTER_SPEED> | ○ | ○ | MENU > TIMECODE > Timecode > FPS |
| <SPEED> | <CURRENT_SPEED> | ○ | × | MENU > TIMECODE > Timecode > FPS |
| <SPEED> | <TIMECODE_RATE> | ○ | × | MENU > TIMECODE > Timecode > FPS |
| <SPEED> | <TIMECODE_FLAG> | ○ | × | MENU > TIMECODE > Timecode > FPS |
| <SPEED> | <FILE_SAMPLE_RATE> | ○ | × | MENU > REC > Sample Rate |
| <SPEED> | <AUDIO_BIT_DEPTH> | ○ | × | MENU > REC > WAV Bit Depth |
| <SPEED> | <DIGITIZER_SAMPLE_RATE> | ○ | × | MENU > REC > Sample Rate |
| <SPEED> | <TIMESTAMP_SAMPLES_SINCE_MIDNIGHT_HI> | ○ | × | |
| <SPEED> | <TIMESTAMP_SAMPLES_SINCE_MIDNIGHT_LO> | ○ | × | |
| <SPEED> | <TIMESTAMP_SAMPLE_RATE> | ○ | × | MENU > REC > Sample Rate |

| iXML master tag | iXML sub tag | Written | Read | Remarks |
|-------------------|-----------------------------|---------|------|---------|
| <SYNC_POINT_LIST> | | | | |
| <SYNC_POINT> | <SYNC_POINT_TYPE> | × | × | |
| <SYNC_POINT> | <SYNC_POINT_FUNCTION> | × | × | |
| <SYNC_POINT> | <SYNC_POINT_COMMENT> | × | × | |
| <SYNC_POINT> | <SYNC_POINT_LOW> | × | × | |
| <SYNC_POINT> | <SYNC_POINT_HIGH> | × | × | |
| <SYNC_POINT> | <SYNC_POINT_EVENT_DURATION> | × | × | |

| iXML master tag | iXML sub tag | Written | Read | Remarks |
|-----------------|---------------------|---------|------|---------|
| <HISTORY> | | | | |
| <HISTORY> | <ORIGINAL_FILENAME> | ○ | × | |
| <HISTORY> | <PARENT_FILENAME> | × | × | |
| <HISTORY> | <PARENT_UID> | × | × | |

| iXML master tag | iXML sub tag | Written | Read | Remarks |
|-----------------|--------------------------|---------|------|---------|
| <FILE_SET> | | | | |
| <FILE_SET> | <TOTAL_FILES> | ○ | × | |
| <FILE_SET> | <FAMILY_UID> | ○ | × | |
| <FILE_SET> | <FAMILY_NAME> | × | × | |
| <FILE_SET> | <FILE_SET_START_TIME_HI> | × | × | |
| <FILE_SET> | <FILE_SET_START_TIME_LO> | × | × | |
| <FILE_SET> | <FILE_SET_INDEX> | ○ | × | |

| iXML master tag | iXML sub tag | Written | Read | Remarks |
|-----------------|--------------------|---------|------|---|
| <TRACK_LIST> | | | | |
| <TRACK_LIST> | <TRACK_COUNT> | ○ | × | |
| <TRACK> | <CHANNEL_INDEX> | ○ | × | |
| <TRACK> | <INTERLEAVE_INDEX> | ○ | × | |
| <TRACK> | <NAME> | ○ | ○ | MENU > META DATA (for Next Take) > Track Name MENU > FINDER > Option > Meta Data Edit > Track Name |
| <TRACK> | <FUNCTION> | × | × | |

Metadata and ID3 fields contained in MP3 files

| Metadata | ID3 field | Format |
|--------------------------------|-------------|--|
| Timecode | Artist Name | TC=[HH:MM:SS:FF] |
| Scene name, take number | Track Title | SC=[scene name] TK=[take number] |
| Frame rate, file length (time) | Album Title | FR=[frame rate] D=[file length (time)] |

Specifications

| | | | |
|-------------------|---|---|--|
| Inputs | INPUT 1–8 | Connectors | XLR/TRS combo jacks (XLR: 2 hot, TRS: TIP hot) |
| | Input source set to “Mic” (→ Setting the input source (Input Source)) | Input gain | +10 – +75 dB |
| | | Input impedance | 3 k Ω or more |
| | | Maximum input level | +4 dBu (at 0 dBFS) |
| | | Phantom power | +24/+48 V, 10 mA maximum per channel |
| | Input source set to “Line” (→ Setting the input source (Input Source)) | Input gain | –10 – +55 dB |
| | | Input impedance | 5 k Ω or more |
| | | Maximum input level | +24 dBu (at 0 dBFS) |
| | Equivalent input noise | | –127 dBu or less (A-weighted, +75 dB input gain, 150 Ω input) |
| | Frequency response | | 20 Hz – 60 kHz, +0.5 dB/–1 dB (192 kHz sample rate) |
| A/D dynamic range | | 113 dB typ. (–60 dBFS input, A-weighted) | |
| Crosstalk | | –90 dB or less (between adjacent channels, 1 kHz) | |
| MIC IN | | ZOOM mic capsule input (use disables Inputs 1/2) | |
| SLATE MIC | | Built-in mic for voice memos can be assigned to tracks freely | |
| Outputs | MAIN OUT 1/2 | Connectors | TA3 connectors (balanced output, 2: hot) |
| | | Output impedance | 150 Ω or less |
| | | Reference output level | –10 dBV (normal output level) +4 dBu (line output level) 1 kHz, 600 Ω load |
| | | Maximum output level | +10 dBV (normal output level) +24 dBu (line output level) 1 kHz, 600 Ω load |
| | SUB OUT 1/2 | Connector | 3.5 mm stereo mini (unbalanced output) |
| | | Output impedance | 100 Ω or less |
| | | Reference output level | –10 dBV (normal output level) –40 dBu (mic output level) 1 kHz, 10 k Ω load |

| | | | |
|-------------------|-------------------|---------------------------------------|---|
| | | Maximum output level | +10 dBV (normal output level) -20 dBu (mic output level) 1 kHz, 10 k Ω load |
| | HEADPHONE | Connector | 1/4 inch stereo (unbalanced output) |
| | | Output impedance | 18 Ω or less |
| | | Maximum output level | 100 mW + 100 mW (32 Ω load) |
| | D/A dynamic range | | 105 dB typ. (-60 dBFS input, A-weighted) |
| Recording media | | Dual SD card slots | SDHC cards: 4 GB - 32 GB SDXC cards: 64 GB - 1 TB |
| Recording formats | When WAV selected | Supported formats | 44.1, 47.952, 48, 48.048, 88.2, 96 and 192 kHz 16-bit Linear, 24-bit Linear, 32-bit Float Mono/stereo/2-10ch poly BWF and iXML |
| | | Maximum simultaneous recording tracks | 10 (8 inputs + stereo mix) 8 (at 192 kHz sampling rate) |
| | When MP3 selected | Supported formats | 128, 192 and 320 kbps 44.1 and 48 kHz ID3v1 tags |
| | | Maximum simultaneous recording tracks | 2 |
| Recording time | | Using a 32 GB card | 23:08:00 (48 kHz/32-bit float stereo WAV) 5:47:00 (192 kHz/32-bit float stereo WAV) |
| Timecode | | Connector | BNC |
| | | Modes | Off, Int Free Run, Int Record Run, Int RTC Run, Ext and Ext Auto Rec (audio clock can be synchronized to timecode) |
| | | Frame rates | 23.976ND, 24ND, 25ND, 29.97ND, 29.97D, 30ND and 30D |
| | | Precision | ± 0.2 ppm |
| | | Supported input levels | 0.2 - 5.0 Vpp |
| | | Input impedance | 4.6 k Ω |
| | | Output level | 3.3 Vpp |
| | | Output impedance | 50 Ω or less |
| Power supplies | | AA batteries | 8 (alkaline, nickel-metal hydride or lithium) |
| | | AC adapter | ZOOM AD-19, DC 12 V/2 A, center plus |

| | | | |
|--|---|---|---|
| | External DC power supply | HIROSE HR10A-7R-4S 4-pin connector (1 pin: -, 4 pin: +), 9–18 V | |
| Estimated continuous recording times* | 2 channels to SD 1 48 kHz sampling frequency (32-bit float/16-bit linear/24-bit linear) MAIN/SUB OUT OFF, TIMECODE OFF, LED/LCD brightness 5, 32 Ω headphones, PHANTOM OFF | Alkaline batteries: about 6 hours NiMH batteries (2500 mAh): about 8.5 hours Lithium batteries: about 12 hours | |
| | 8 channels to SD 1 48 kHz sampling frequency (32-bit float/16-bit linear/24-bit linear) MAIN/SUB OUT OFF, TIMECODE OFF, LED/LCD brightness 5, 32 Ω headphones, PHANTOM OFF | Alkaline batteries: about 5 hours NiMH batteries (2500 mAh): about 7 hours Lithium batteries: about 10 hours | |
| | 8 channels to SD 1/2 192 kHz sampling frequency (32-bit float/16-bit linear/24-bit linear) MAIN/SUB OUT ON, TIMECODE Int Free Run, LED/LCD brightness 60, 32 Ω headphones, PHANTOM 48 V | Alkaline batteries: about 0.5 hours NiMH batteries (2500 mAh): about 1.5 hours Lithium batteries: about 2.5 hours | |
| | * These values are only estimates. They are based on in-house testing methods. They will vary greatly according to use conditions. | | |
| Display | | 2.4 inch full-color LCD (320 × 240) | |
| USB | Connector | Mini-B • Use a USB cable that supports data transfer. USB bus power operation is not supported. | |
| | Mass storage operation | Class USB 2.0 High Speed | |
| | Multi Track audio interface mode operation (driver required for Windows, not required for Mac) | Class | USB 2.0 High Speed |
| | | Specifications | Sampling rate: 44.1/48/88.2/96 kHz Bit depth: 24-bit linear/32-bit float 8-in/4-out |
| | Stereo Mix audio interface mode operation (no driver required) • Supports audio interface operation with iOS/iPadOS devices | Class | USB 2.0 Full Speed |
| Specifications | | Sampling rate: 44.1/48 kHz Bit depth: 16-bit linear 2-in/2-out | |
| Audio interface operation with recording (driver required for Windows, not required for Mac) | Class | USB 2.0 High Speed | |
| | Specifications | Sampling rate: 44.1/48 kHz Bit depth: 24-bit linear/32-bit float 10-in/4-out | |
| Power consumption | | 15 W | |

| | |
|------------------------------|--|
| External dimensions | 7.0 in. (W) × 5.5 in. (D) × 2.1 in. (H) 178.2 mm (W) × 140.3 mm (D) × 54.3 mm (H) |
| Weight (including batteries) | 1200 g |

Note: 0 dBu = 0.775 Vrms



ZOOM CORPORATION

4-4-3 Kanda-surugadai, Chiyoda-ku, Tokyo 101-0062 Japan

zoomcorp.com